

## Operation Setup & Cleaning



*Lo-Boy model shown*

---

# Graco Airless Sprayer 495

---

**Sprayer training overview  
( Insert only) Refer to  
Owner's Manual for full  
details & warnings**

---

**Phillro Industries Pty Ltd  
Ph: 1300 503 610  
Fax: (07) 3399 5955  
Email: [infoqld@phillro.com.au](mailto:infoqld@phillro.com.au)  
[www.phillro.com.au](http://www.phillro.com.au)**

---

# Table of Contents

Page 3:	Component Identification
Page 4 - 6:	Sprayer Setup / Installation
Page 7 - 8:	Start up / Priming the Sprayer
Page 9:	Tip Guard Setup / Spray Tip
Page 10:	Spraying techniques
Page 11:	Clearing blocked Spray Tip
Page 12 – 15	Cleaning Paint from Sprayer / Proper Storage Liquids
Page 16 – 17	<b>Safety Warnings</b>

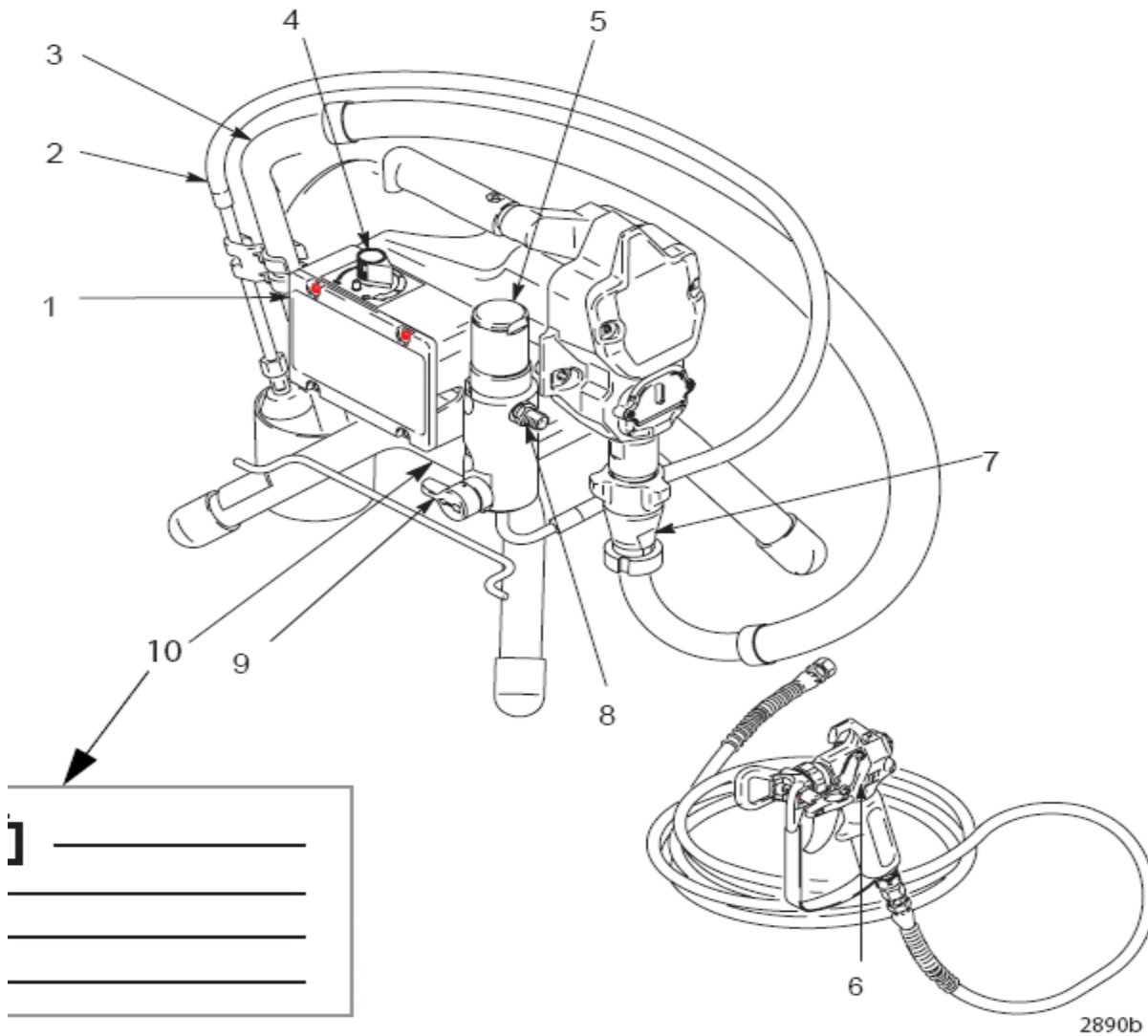

	English
1	ON/OFF switch
2	Drain tube
3	Siphon tube
4	Pressure control
5	Filter
6	Trigger lock
7	Pump
8	Fluid outlet
9	Prime/Spray valve
10	Service Tag (below sprayer frame)

Graco 495 Stand Unit Shown

# Setup / Installation – Follow steps in numerical order

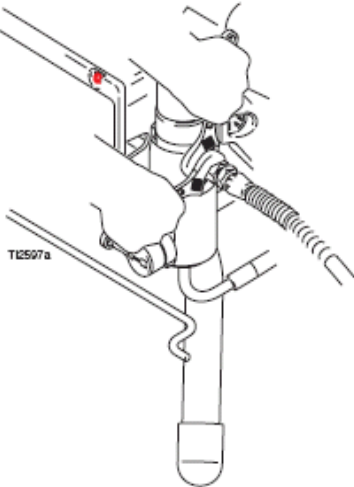
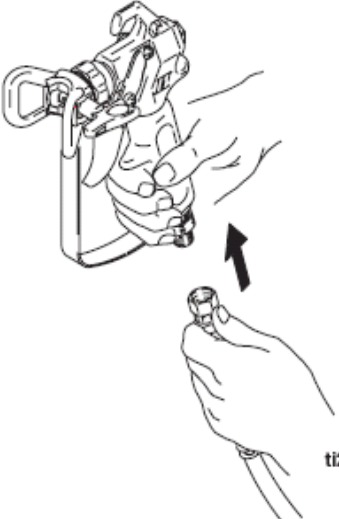
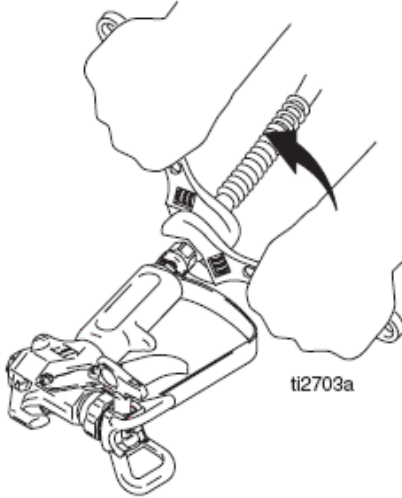
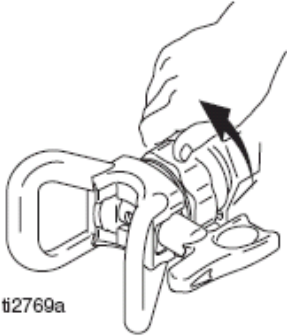
 <p>ti2597a</p>	 <p>ti2702a</p>	 <p>ti2703a</p>	 <p>ti2769a</p>
<p>1 Connect Graco airless hose to sprayer. Tighten securely.</p>	<p>2 Connect other end of hose to gun.</p>	<p>3 Tighten securely.</p>	<p>4 Remove tip guard.</p>

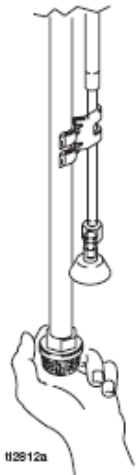

5 Check inlet strainer for clogs and debris.

Approximate Fill Level

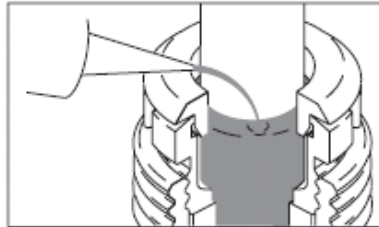

6 Fill throat packing nut with TSL to prevent premature packing wear. Do this each time you spray.

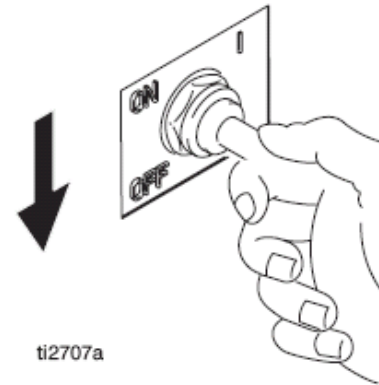

7 Turn power OFF.

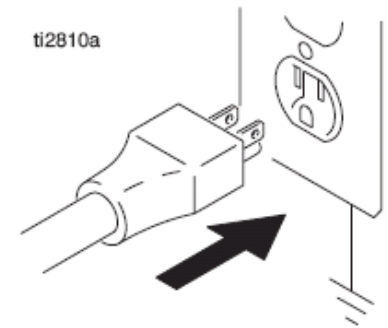

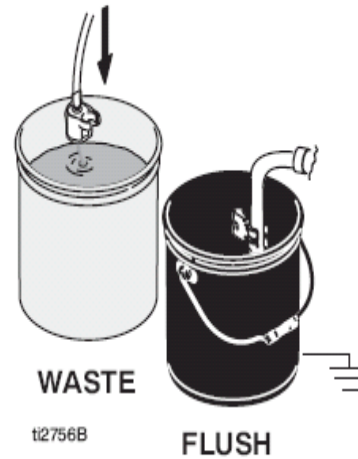

8 Plug power supply cord into a properly grounded electrical outlet.



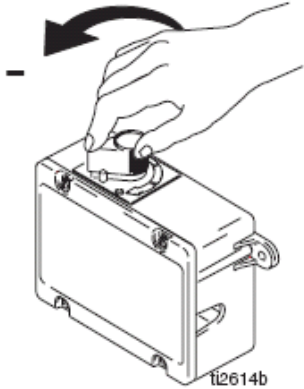
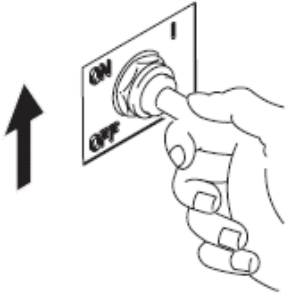
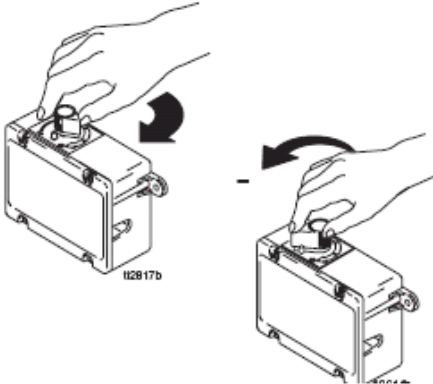

9 Turn prime valve down.

10 Place siphon tube set in grounded metal pail partially filled with flushing fluid. Attach ground wire to pail and to true earth ground. Do 1. - 5. of **Startup**, page 23 to flush out storage oil shipped in sprayer. Use water to flush water-base paint and mineral spirits to flush oil-base paint and storage oil.

## Start up / Spray

			
<p>1 Turn pressure control to lowest pressure.</p>	<p>2 Turn power <b>ON</b>.</p>	<p>3 Increase pressure to start motor and allow fluid to circulate through drain tube for 15 seconds; then turn pressure down.</p>	<p>4 Turn prime valve horizontal. Take spray gun trigger safety <b>OFF</b>.</p>

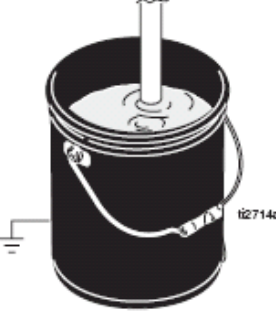
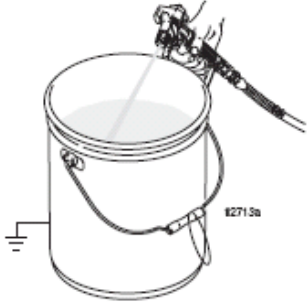
<p>t2599a</p>  <p>WASTE</p>		 <p>PAINT</p>	 <p>WASTE</p>
<p>5 Hold gun against grounded metal flushing pail. Trigger gun and increase fluid pressure to 1/2. Flush 1 minute.</p>	<p>Inspect for leaks. Do not stop leaks with hand or a rag! If leaks occur, do Pressure Relief. Tighten fittings. Do <b>Startup</b>, 1. - 5, page 23. If no leaks, proceed to 6.</p>	<p>6 Place siphon tube in paint pail. 7 Trigger gun again into flushing pail until paint appears. Move gun to paint pail and trigger for 20 seconds. Set gun safety ON. Assemble tip and guard, page 25.</p>	

# Spray Tip Guard Assembly

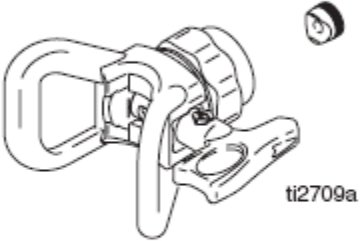
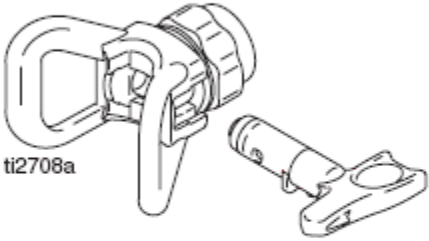
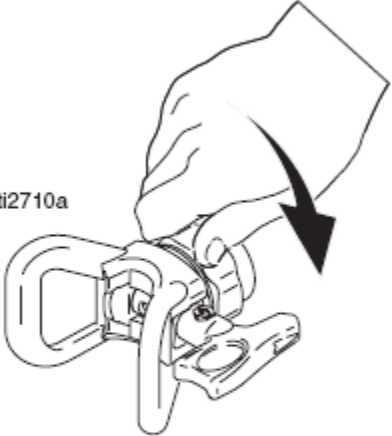
 <p>ti2709a</p>	 <p>ti2708a</p>	 <p>ti2710a</p>
<p>1 Insert metal seal and OneSeal.</p>	<p>2 Insert SwitchTip.</p>	<p>3 Screw assembly onto gun. Tighten.</p>

# Spraying

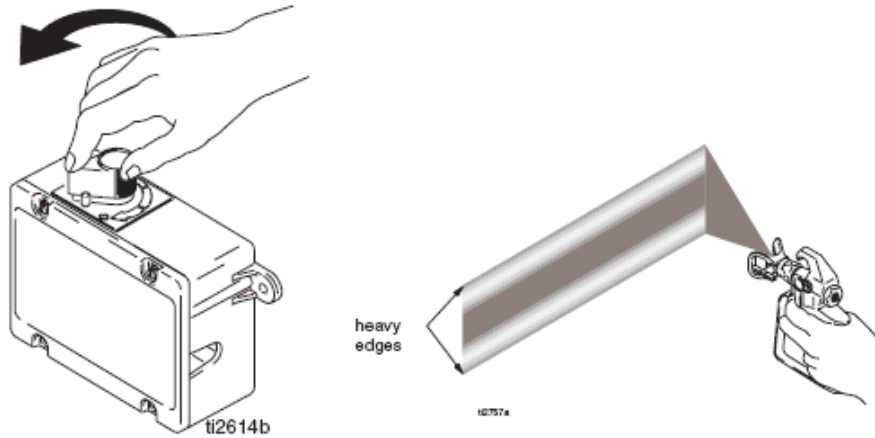

- 1 Spray test pattern. Start with pressure turned to its lowest setting, then gradually increase pressure gradually until you achieve a consistent spray pattern without heavy edges. Use smaller tip size if pressure adjustment can not eliminate heavy edges.

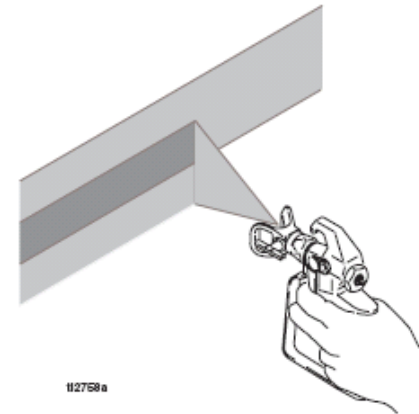

- 2 Hold gun perpendicular, 10-12 in. from surface. Spray back and forth, overlapping by 50%. To prevent heavy spots, before pulling trigger, first move gun using a back and forth motion. When you stop spraying, after releasing trigger, continue to move gun back and forth for a few seconds.

# Clearing Blocked Spray Tip



Caution Keep Hands Clear Injection Hazard

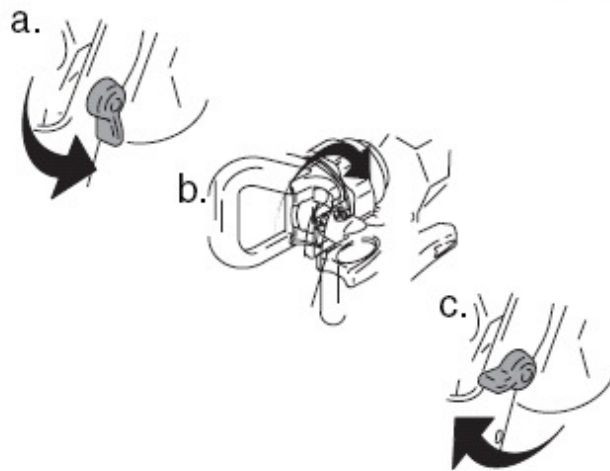

- 1 a.) Release trigger, put safety ON.  
b.) Rotate SwitchTip.  
c.) Take safety OFF.  
d.) Trigger gun to clear clog. Never point gun at your hand or into a rag!

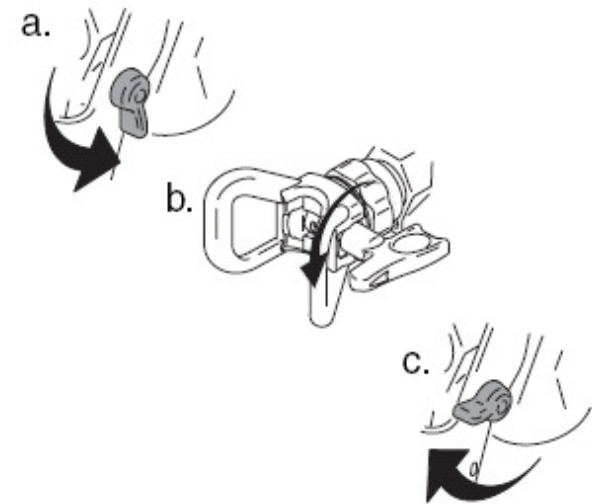



- 2 a.) Put safety ON.  
b.) Return Switch to original position.  
c.) Take safety OFF and continue spraying.

# Cleaning Paint from Machine

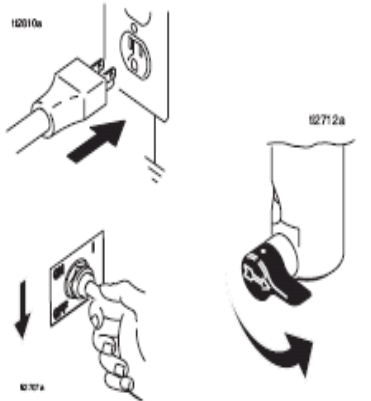
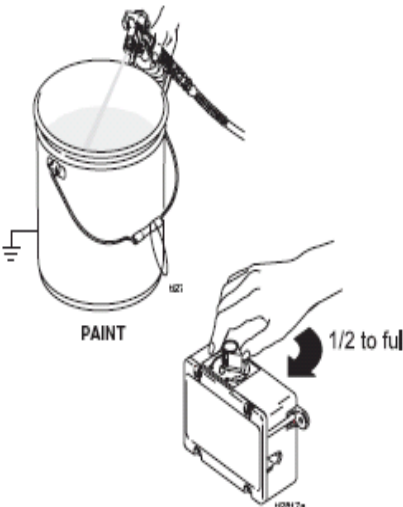

<p>1 Turn power <b>OFF</b> and unplug sprayer</p>	<p>2 Turn pressure to lowest setting. Trigger gun to relieve pressure.</p>	<p>3 Put drain tube in pail. Turn prime valve down.</p>	<p>4 Remove guard and SwitchTip.</p>

 <p>Diagram 5 shows two buckets. The bucket on the left is labeled 'WASTE' and contains a siphon tube set. An arrow points down into the bucket. The bucket on the right is labeled 'PAINT' and contains a siphon tube set. An arrow points down into the bucket.</p>	 <p>Diagram 6 shows a hand plugging a power cord into a wall outlet. The outlet is labeled '12010a'. A hand is shown turning a switch on the outlet to the 'ON' position. The switch is labeled '12712a'.</p>	 <p>Diagram 7 shows a hand holding a spray gun against a bucket labeled 'PAINT'. The bucket is labeled '12712a'. A hand is shown turning a dial on the spray gun to '1/2 to full'. The dial is labeled '12017a'.</p>	 <p>Diagram 8 shows a hand holding a spray gun against a bucket labeled 'WASTE'. The bucket is labeled '12599a'.</p>
<p>5 Remove siphon tube set from paint and place in flushing fluid. Use water for water base paint and mineral spirits for oil base paint.</p>	<p>6 Plug in sprayer. Turn power <b>ON</b>. Turn prime valve horizontal.</p>	<p>7 Hold gun against paint pail. Take trigger safety <b>OFF</b>. Trigger gun and increase pressure until flushing fluid appears</p>	<p>8 Move gun to flushing pail, hold gun against pail, trigger gun to thoroughly flush system. Release trigger and put trigger safety <b>ON</b>.</p>

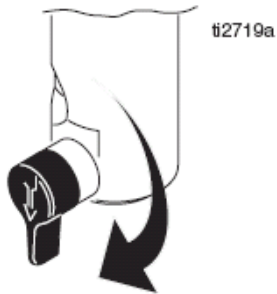

9 Turn prime valve down and allow flushing fluid to circulate for 1 to 2 minutes to clean drain tube.

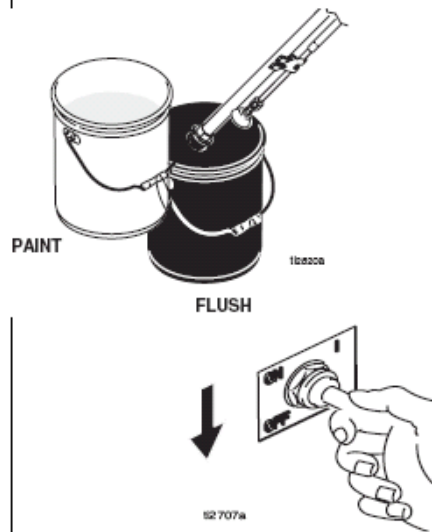

10 Raise siphon tube above flushing fluid and run sprayer for 15 to 30 seconds to drain fluid. Turn power **OFF**

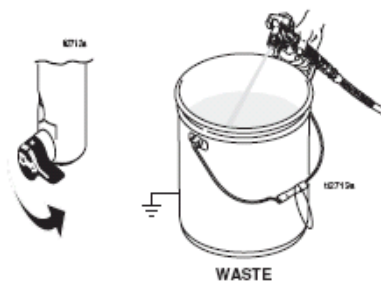

11 Close drain valve. Trigger gun into flushing pail to purge fluid from hose.

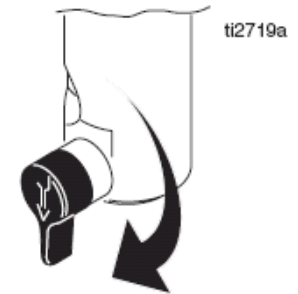

12 Open prime valve.



t2814a

13 Remove filters from gun and sprayer, if installed. Clean and inspect. Install filters.



Pump Armor





t2895a





14 If flushing with water, flush again with mineral spirits, or Pump Armor, to leave a protective coating to prevent freezing or corrosion.



t2776a

15 Wipe sprayer, hose and gun with a rag soaked in water or mineral spirits.

 <b>WARNING</b>	
	<p><b>FIRE AND EXPLOSION HAZARD</b></p> <p>Flammable fumes, such as solvent and paint fumes, in work area can ignite or explode. To help prevent fire and explosion:</p> <ul style="list-style-type: none"> <li>• Use equipment only in well ventilated area.</li> <li>• Eliminate all ignition sources; such as pilot lights, cigarettes, portable electric lamps, and plastic drop cloths (potential static arc).</li> <li>• Sprayer generates sparks. When flammable liquid is used in or near the sprayer or for flushing or cleaning, keep sprayer at least 20 feet (6 m) away from explosive vapors.</li> <li>• Keep work area free of debris, including solvent, rags and gasoline.</li> <li>• Do not plug or unplug power cords or turn lights on or off when flammable fumes are present.</li> <li>• Ground equipment and conductive objects in work area. Read <b>Grounding</b> instructions.</li> <li>• If there is static sparking or you feel a shock, <b>stop operation immediately</b>. Do not use equipment until you identify and correct the problem.</li> <li>• Keep a fire extinguisher in the work area.</li> </ul>
	<p><b>ELECTRIC SHOCK HAZARD</b></p> <p>Improper grounding, setup, or usage of the system can cause electric shock.</p> <ul style="list-style-type: none"> <li>• Turn off and disconnect power cord before servicing equipment.</li> <li>• Use only grounded electrical outlets.</li> <li>• Use only 3-wire extension cords.</li> <li>• Ensure ground prongs are intact on sprayer and extension cords.</li> <li>• Do not expose to rain. Store indoors.</li> </ul>
	<p><b>SKIN INJECTION HAZARD</b></p> <p>High-pressure fluid from gun, hose leaks, or ruptured components will pierce skin. This may look like just a cut, but it is a serious injury that can result in amputation. <b>Get immediate surgical treatment.</b></p> <ul style="list-style-type: none"> <li>• Do not point gun at anyone or at any part of the body.</li> <li>• Do not put your hand over the spray tip.</li> <li>• Do not stop or deflect leaks with your hand, body, glove, or rag.</li> <li>• Engage trigger lock when not spraying.</li> <li>• Follow <b>Pressure Relief Procedure</b> in this manual, when you stop spraying and before cleaning, checking, or servicing equipment.</li> </ul>

 <b>WARNING</b>	
	<p><b>EQUIPMENT MISUSE HAZARD</b> Misuse can cause death or serious injury.</p> <ul style="list-style-type: none"> <li>• Do not exceed the maximum working pressure or temperature rating of the lowest rated system component. Read <b>Technical Data</b> in all equipment manuals.</li> <li>• Use fluids and solvents that are compatible with equipment wetted parts. Read <b>Technical Data</b> in all equipment manuals. Read fluid and solvent manufacturer's warnings. For complete information about your material, request MSDS from distributor or retailer.</li> <li>• Check equipment daily. Repair or replace worn or damaged parts immediately with genuine Graco replacement parts only.</li> <li>• Do not alter or modify equipment.</li> <li>• Use equipment only for its intended purpose. Call your Graco distributor for information.</li> <li>• Route hoses and cables away from traffic areas, sharp edges, moving parts, and hot surfaces.</li> <li>• Do not kink or overbend hoses or use hoses to pull equipment.</li> <li>• Comply with all applicable safety regulations.</li> <li>• Keep children and animals away from work area.</li> <li>• Do not operate the unit when fatigued or under the influence of drugs or alcohol.</li> </ul>
	<p><b>PRESSURIZED ALUMINUM PARTS HAZARD</b> Do not use 1,1,1-trichloroethane, methylene chloride, other halogenated hydrocarbon solvents or fluids containing such solvents in pressurized aluminum equipment. Such use can cause serious chemical reaction and equipment rupture, and result in death, serious injury, and property damage.</p>
	<p><b>TOXIC FLUID OR FUMES HAZARD</b> Toxic fluids or fumes can cause serious injury or death if splashed in the eyes or on skin, inhaled, or swallowed.</p> <ul style="list-style-type: none"> <li>• Read MSDS's to know the specific hazards of the fluids you are using.</li> <li>• Store hazardous fluid in approved containers, and dispose of it according to applicable guidelines.</li> </ul>
	<p><b>PERSONAL PROTECTIVE EQUIPMENT</b> You must wear appropriate protective equipment when operating, servicing, or when in the operating area of the equipment to help protect you from serious injury, including eye injury, inhalation of toxic fumes, burns, and hearing loss. This equipment includes but is not limited to:</p> <ul style="list-style-type: none"> <li>• Protective eye wear</li> <li>• Clothing and respirator as recommended by the fluid and solvent manufacturer</li> <li>• Gloves</li> <li>• Hearing protection</li> </ul>