

Owner and Vehicle Identification

This information fully identifies your vehicle. It will furnish all of the necessary information in the event that warranty repairs are required. Be certain it is completely and properly filled out and signed by your Selling Dealer.

Owner's Name:

Business Name:

Address:

City / Town:

State: Postcode:

Business Phone: Private Phone:

Mobile: Email:

Registration Number:

Isuzu Truck Model:

Vehicle Identification Number:

IAL Tag Number:

Engine Number:

Transmission Serial Number:

Differential Serial Number:

Selling Dealer's Signature and Stamp:

Date:



Symbols Used in This Manual

DANGER

Failure to follow these instructions identified by this symbol could result in death or serious injury to you and/or other people.

WARNING

Failure to follow these instructions identified by this symbol could result in a fire inside your vehicle in addition to death or serious injury to you and/or other people.

CAUTION

Failure to follow these instructions identified by this symbol could result in injuries or an accident.

ADVICE



Failure to follow these instructions identified by this symbol could cause malfunction or damage to your vehicle.

NOTE

This symbol identifies information that you need to know.

This symbol also identifies information that would be useful for operating the vehicle.

The following symbols are also used in this manual.

-  : Market-/type-specific equipment (Your vehicle may not have the equipment with this symbol.)
-  : Manual transmission model
-  : Vehicle equipped with the AMT system

Abbreviations

This manual uses the following acronyms, as interpreted below.

Abbreviations	Description
ABS	Anti-lock Brake System
ACEA	Association des Constructeurs Europeens d'Automobiles (Association of European Automobile Constructors)
AMT	Automated Manual Transmission
API	American Petroleum Institute
ASR	Anti-Slip Regulator
ASTM	American Society for Testing and Materials
BS	British Standard
DIN	Deutsche Industrie Normen
DPD	Diesel Particulate Defuser
EBD	Electronic Braking force Distribution
ELR	Emergency Locking Retractor
FMVSS	Federal Motor Vehicle Safety Standards
GVM	Gross Vehicle Mass
HBB	Hydraulic Brake Booster
HSA	Hill-Start-Aid
JASO	Japanese Automobile Standards Organization
JIS	Japanese Industrial Standards
LLC	Long Life Coolant
LSD	Limited Slip Differential
LSPV	Load Sensing Proportioning Valve
M/T	Manual Transmission
MID	Multi-Information Display
MIL	A United States Defense Standard (Military Standard)
PM	Particulate Matter
PTO	Power Take-Off
r/min	revolutions per minute
SAE	Society of Automotive Engineers
SRS	Supplemental Restraint System
SVS	Service Vehicle Soon
2WD	Two Wheel Drive
4WD	Four Wheel Drive

HOW TO USE THIS MANUAL AND HOW TO FIND A SPECIFIC TOPIC

0

• HOW TO USE THIS MANUAL	0-2
• HOW TO FIND A SPECIFIC TOPIC	0-3
• CHAPTER DESCRIPTION	0-5
• PICTORIAL INDEX	0-6
• WARNING/INDICATOR LIGHT INDEX	0-13
• WARNING/CAUTION LABELS	0-18

Chapter/section titles

These titles are useful for getting the gist of the content at a glance.

Chapter index tab

Use this for quick access to your desired chapter.

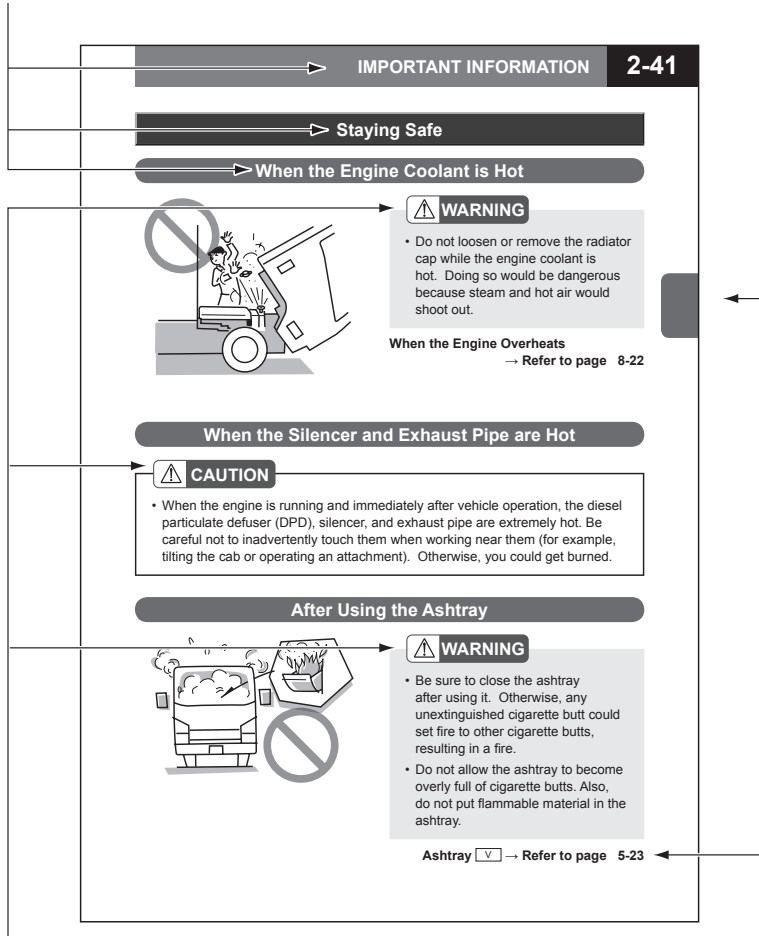

- DANGER**
- WARNING** **CAUTION**
- ADVICE** **NOTE**

Symbols

See the preceding page for the meanings of these symbols.

All values in this manual are indicated primarily according to the International System of Units (or in SI units) with the conventional metric values and American units indicated in parentheses.
 Note: This page is shown only as an example. It is not intended to give you information on your particular vehicle.

Reference page

Refers you to a page (or pages) of this manual that concerns the present topic and that you should also read.



Use chapter/section titles as keys
➔ Page 0-5

Search for the page describing the specific topic by using the general table of contents under CHAPTER DESCRIPTION, the CHAPTER INDEX, and/or the TABLE OF CONTENTS on the first page of each chapter.

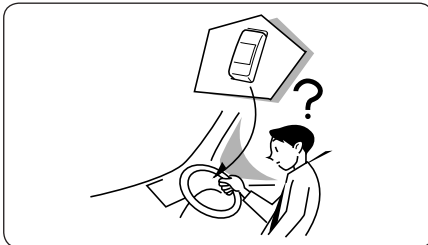

Use the pictorial indexes
➔ Pages 0-6 to 0-12

PICTORIAL INDEX

If you don't know the name of the switch or other device for which you need information, locate the page describing it by using the pictorial indexes.

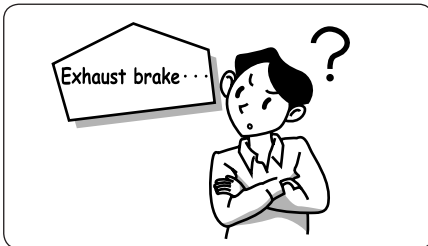

Use device names as keys
➔ Pages 10-1 to 10-4

INDEX

If you know the name of the switch or other device for which you need information, locate the page describing it by using the Index at the end of this manual.

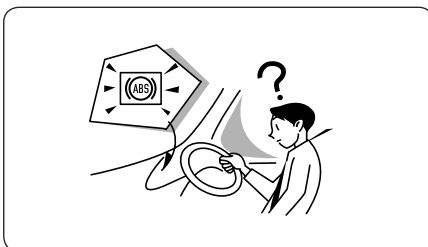

Use the Warning/Indicator Light Index
➔ Pages 0-13 to 0-17

WARNING/INDICATOR LIGHT INDEX

If a warning or indicator light is illuminated, you can use the WARNING/INDICATOR LIGHT INDEX to find the page that provides information on the light.

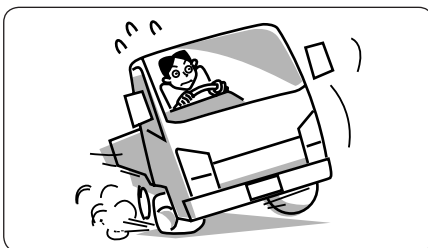

If you have a problem with your vehicle
➔ Pages 8-2 to 8-46

IN CASE OF EMERGENCY



PICTORIAL INDEX 0-6**VEHICLE INFORMATION 1**

Chassis and Engine Numbers. Vehicle Identification. Change of ownership or address.

IMPORTANT INFORMATION 2

Warranty statement. Customer assistance. What you should know before you can operate the vehicle safely and smoothly.

DOORS, WINDOWS AND SEATS 3

How to open/close the doors, windows and fuel filler cap. Also explains how to adjust the mirrors and seats including how to correctly fasten the seat belts.

CONTROLS AND INSTRUMENTS 4

Explains how to start and stop the engine; describes various controls and instruments; describes special equipment such as the AMT and HSA.

COMFORT AND CONVENIENCE 5

Contains information on the audio system, air conditioning system, and other comfort and convenience features.

TIPS ON SAFE AND SMOOTH OPERATION.. 6

Describes the points you should be aware of to operate the vehicle safely and smoothly under various conditions and in different seasons.

SERVICE AND MAINTENANCE 7

Daily and periodic inspections. Maintenance schedules. Recommended lubricants. Other care and maintenance information.

IN CASE OF EMERGENCY 8

Details possible emergency situations and describes the actions you should take to deal with any one of them.

MAIN DATA 9**INDEX 10**

NLR Model

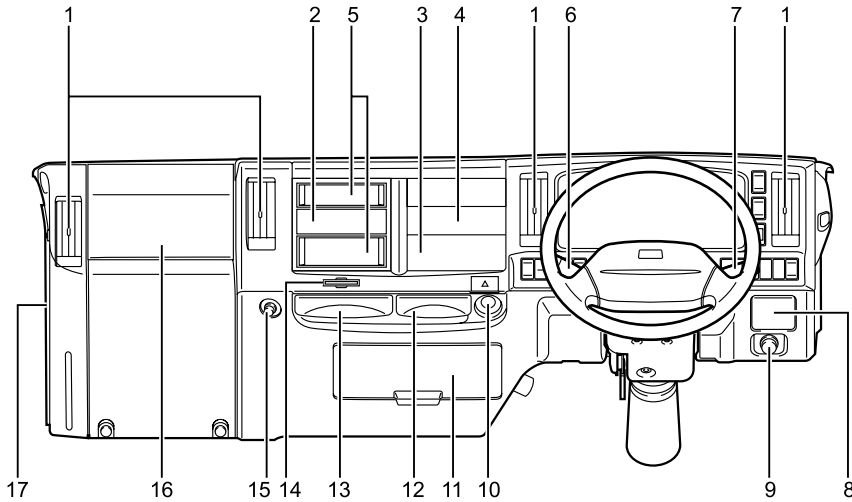

No.	Equipment	Page
1	Air flow direction control lever	5-2
2	<input type="checkbox"/> Not used	
3	Heater / air conditioner	5-5
4	<input type="checkbox"/> CD player (with AM/FM radio)	-
5	<input type="checkbox"/> Small article storage pocket	5-25
6	Exhaust brake switch	4-69
	Windshield washer and wiper switch	4-71

No.	Equipment	Page
7	Combination light control switch	4-64
8	<input type="checkbox"/> Ashtray	5-23
9	<input type="checkbox"/> Idling control knob	4-62
10	Cigarette lighter	5-22
11	Relay box	8-40
12	<input type="checkbox"/> Ashtray	5-23
13	<input type="checkbox"/> Cup holder	5-27
14	Card holder	5-25
15	Hook	5-29
16	<input type="checkbox"/> Passenger's SRS airbag	4-143
	<input type="checkbox"/> Glove compartment	5-26
17	Windshield washer fluid tank	7-133

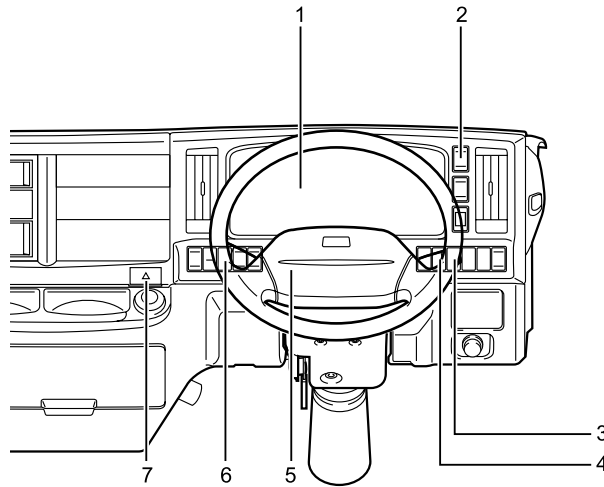

No.	Equipment	Page
1	Instruments, warning lights and indicator lights	4-8 4-15
2	<input type="checkbox"/> Front fog light switch	4-67
3	<input type="checkbox"/> SA AMT adjustment switch	4-93
4	<input type="checkbox"/> SA AMT emergency switch	4-95

No.	Equipment	Page
5	Horn button	4-73
	<input type="checkbox"/> Driver's SRS airbag	4-143
6	DPD switch	4-154
7	Hazard warning flasher switch	4-68

NNR/NPR/NQR/NPS Models

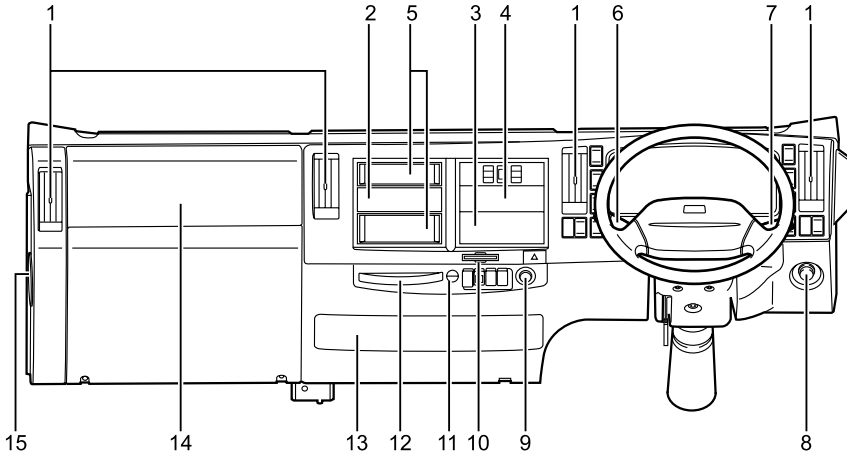

No.	Equipment	Page
1	Air flow direction control lever	5-2
2	<input type="checkbox"/> Not used	
3	<input type="checkbox"/> Ventilator	5-3
	<input type="checkbox"/> Heater/manual air conditioner	5-5
	<input type="checkbox"/> Automatic air conditioner	5-12
4	<input type="checkbox"/> CD player (with AM/FM radio)	-
5	<input type="checkbox"/> Small article storage pocket	5-25

No.	Equipment	Page
6	Exhaust brake switch	4-69
	Windshield washer and wiper switch	4-71
7	Combination light control switch	4-64
8	<input type="checkbox"/> Idling control knob	4-62
9	Cigarette lighter	5-22
10	Card holder	5-25
11	Hook	5-29
12	<input type="checkbox"/> Cup holder	5-27
13	Relay box	8-40
14	<input type="checkbox"/> Passenger's SRS airbag	4-143
	<input type="checkbox"/> Glove compartment	5-26
15	Windshield washer fluid tank	7-133

Model without Power Take-Off (PTO)

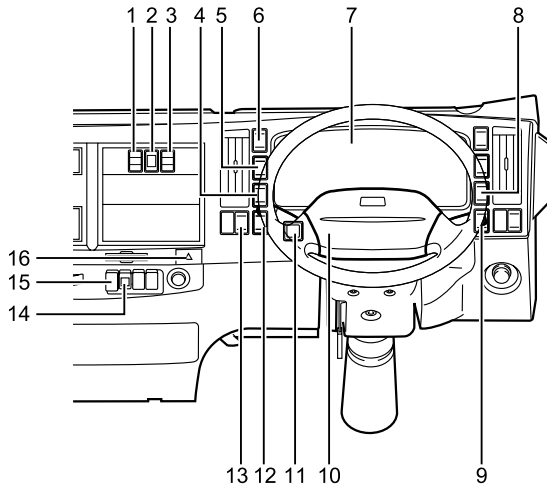

No.	Equipment	Page
1	<input type="checkbox"/> V Left rear window switch	3-11
2	<input type="checkbox"/> V Rear window lock switch	3-11
3	<input type="checkbox"/> V Right rear window switch	3-11
4	<input type="checkbox"/> V Cruise control main switch	4-108
5	<input type="checkbox"/> V Transfer gear control switch	4-127
6	<input type="checkbox"/> V ASR OFF switch	4-120
	<input type="checkbox"/> V 4WD switch	4-124
7	Instruments, warning lights and indicator lights	4-8 4-15
8	<input type="checkbox"/> V Front fog light switch	4-67
9	<input type="checkbox"/> V Headlight leveling switch	4-66
10	Horn button	4-73
	<input type="checkbox"/> V Driver's SRS airbag	4-143

No.	Equipment	Page
11	<input type="checkbox"/> V Remote control mirror switch	4-73
12	<input type="checkbox"/> V HSA OFF switch	4-98
	DPD switch	4-154
13	<input type="checkbox"/> V Mirror heater switch	4-74
14	<input type="checkbox"/> V HSA adjustment switch	4-98
	<input type="checkbox"/> SA AMT adjustment switch	4-93
	<input type="checkbox"/> V HSA reset switch	4-104
15	<input type="checkbox"/> SA AMT emergency switch	4-95
	Hazard warning flasher switch	4-68

Model with PTO

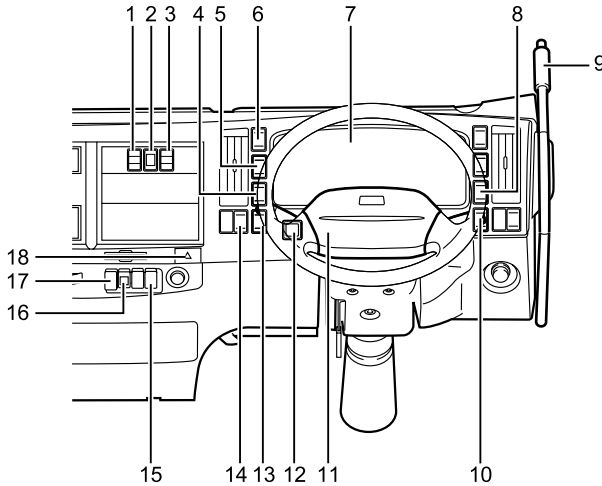

No.	Equipment	Page
1	<input type="checkbox"/> V Left rear window switch	3-11
2	<input type="checkbox"/> V Rear window lock switch	3-11
3	<input type="checkbox"/> V Right rear window switch	3-11
4	<input type="checkbox"/> V Cruise control main switch	4-108
5	<input type="checkbox"/> V Transfer gear control switch	4-127
6	<input type="checkbox"/> V ASR OFF switch	4-120
	<input type="checkbox"/> V 4WD switch	4-124
7	Instruments, warning lights and indicator lights	4-8 4-15
8	<input type="checkbox"/> V Front fog light switch	4-67
9	<input type="checkbox"/> V PTO lever	4-128
10	<input type="checkbox"/> V Headlight leveling switch	4-66
11	Horn button	4-73
	<input type="checkbox"/> V Driver's SRS airbag	4-143

No.	Equipment	Page
12	<input type="checkbox"/> V Remote control mirror switch	4-73
13	<input type="checkbox"/> V HSA OFF switch	4-98
	DPD switch	4-154
14	<input type="checkbox"/> V Mirror heater switch	4-74
15	<input type="checkbox"/> V PTO switch	4-130
16	<input type="checkbox"/> SA HSA adjustment switch	4-98
	<input type="checkbox"/> SA AMT adjustment switch	4-93
17	<input type="checkbox"/> V HSA reset switch	4-104
	<input type="checkbox"/> SA AMT emergency switch	4-95
18	Hazard warning flasher switch	4-68

Interior

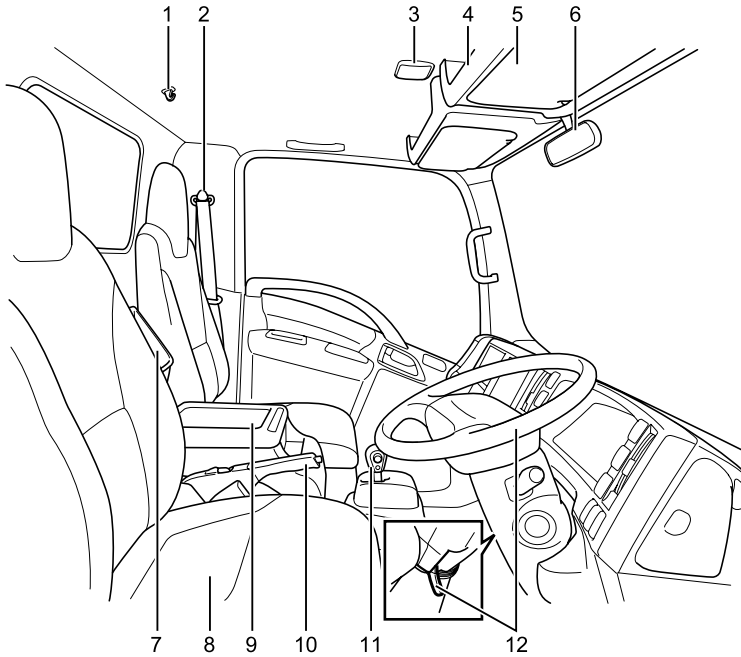

No.	Equipment	Page
1	<input type="checkbox"/> Coat hook	5-29
2	Seat Belt	3-23
3	Dome light	5-20
4	<input type="checkbox"/> Overhead tray	5-27
5	Sun visor	5-21
6	<input type="checkbox"/> Inside mirror	3-22

No.	Equipment	Page
7	<input type="checkbox"/> Back panel tray (storage receptacle)	5-28
8	Seat	3-17
9	<input type="checkbox"/> Centre console box	5-26
10	Parking brake lever	4-77
11	Gear shift lever	4-78
12	Fully adjustable steering	3-21

Exterior

NLR/NNR/NPR/NQR/NPS Models

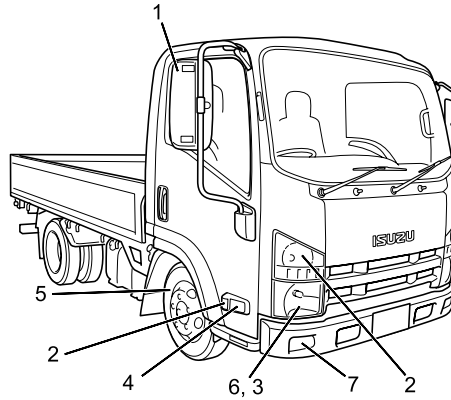







No.	Equipment	Page
1	Outside rearview mirrors	3-22
2	Turn signal light	8-24
3	Clearance light	8-24
4	<input type="checkbox"/> Cornering light	8-24

No.	Equipment	Page
5	Tyres	7-80
6	Headlight	8-24
7	<input type="checkbox"/> Front fog light	8-24



Warning/Indicator Light Index















Multi-Information Display (MID)





WARNING LIGHTS

Message	Display indication	Color	Page
Low fuel		Amber	4-50
Water separator (fuel filter)		Red	4-43
Engine overheating		Red	4-39
Meter failure		Red	4-57
CAN system error		Red	4-57
Over speed		Red	4-38
Abnormal voltage		Red	4-22

INDICATOR LIGHTS







Message	Display indication	Color	Page
Automatic regeneration of DPD		Green	4-56
PM level being checked for selectable DPD regeneration		Amber	4-56
Manual regeneration of DPD in progress		Amber	4-56





Message	Display indication	Color	Page
Push DPD switch		Amber	4-56
DPD PM level		Green	4-27
Progress of DPD regeneration		Amber	4-27
Engine oil level check		Amber	4-41
Air cleaner check		Amber	4-41
Engine oil and filter		Green	4-40
Transmission oil		Green	4-45
AMT clutch oil		Green	4-46
Fuel filter		Green	4-47
Power steering fluid		Green	4-48
Tyre rotation		Green	4-49
Total fuel economy		Green	4-21
Per trip fuel economy		Green	4-21
Instantaneous fuel economy		Green	4-21

Message	Display indication	Color	Page
Calendar		Green	4-23
Clock		Green	4-24
Hour meter		Green	4-14
Over speed		Green	4-32
Nighttime dimmer		Green	4-25







Instrument Panel













WARNING LIGHTS

Name	Symbol	Color	Page
Check engine warning light		Amber	4-42
Engine oil pressure warning light		Red	4-38
Engine overheat warning light		Red	4-39
<input type="checkbox"/> ABS warning light		Amber	4-37
<input type="checkbox"/> SRS airbag warning light		Red	4-34
Alternator warning light		Red	4-42
<input type="checkbox"/> SA AMT warning light		Amber	4-44

Name	Symbol	Color	Page
Water separator (fuel filter) warning light		Red	4-43
Brake system warning light		Red	4-35
Parking brake warning light		Red	4-51
Brake booster warning light		Red	4-36
Seat belt warning light		Red	4-34

INDICATOR LIGHTS

Name	Symbol	Color	Page
<input type="checkbox"/> HSA indicator light		Green	4-52
<input type="checkbox"/> Warm-up system indicator light		Amber	4-53
Glow plug indicator light		Amber	4-53
<input type="checkbox"/> Cruise control main indicator light		Green	4-54
<input type="checkbox"/> Cruise control set indicator light		Green	4-54
High beam indicator light		Blue	4-51
<input type="checkbox"/> ASR indicator light		Green/ amber	4-53

Name	Symbol	Color	Page
Exhaust brake indicator light		Green	4-52
<input type="checkbox"/> 4WD indicator light		Green	4-55
<input type="checkbox"/> SA ECONO mode indicator light		Green	4-54
<input type="checkbox"/> SA 1st start mode indicator light		Green	4-54
<input type="checkbox"/> Transfer LOW indicator light		Amber	4-44
Turn signal and hazard warning indicator light – left		Green	4-50
Turn signal and hazard warning indicator light – right		Green	4-50
<input type="checkbox"/> Rear Fog Light Indicator Light		Amber	4-51
SVS indicator light		Amber	4-43
<input type="checkbox"/> DPD automatic regeneration indicator light		Green	4-55
<input type="checkbox"/> DPD manual regeneration indicator light		Amber	4-55
<input type="checkbox"/> PTO indicator light		Red	4-55
Low fuel warning light	 Low fuel warning light	Amber	4-50

Warning/Caution Labels in Your Vehicle

- The warning/caution labels in your vehicle indicate very important instructions and information that you should respect to ensure safe and proper use of the vehicle. Be sure to read them before using the vehicle.
- If any of these labels are peeling or illegible due to wear or scratches, please contact your Isuzu Dealer for a replacement.
- Some examples of warning/caution labels are indicated on the following pages, but there are many others not shown. Also, the contents of these labels may vary from model to model.
- The warning/caution labels indicated may be located differently in your vehicle.

Warning/Caution Labels – Cab Interior

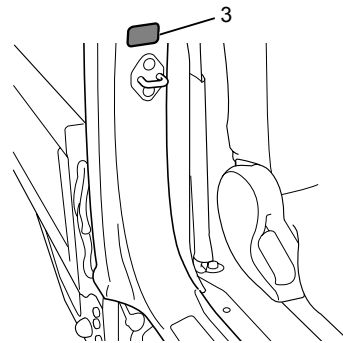
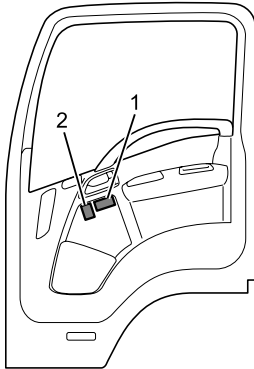

No.	Description
1	PTO operation
2	Gear shifting (5-speed manual transmission model), dump control lever
3	Tyre air pressure

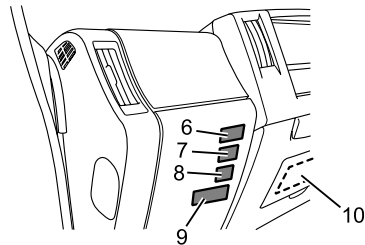
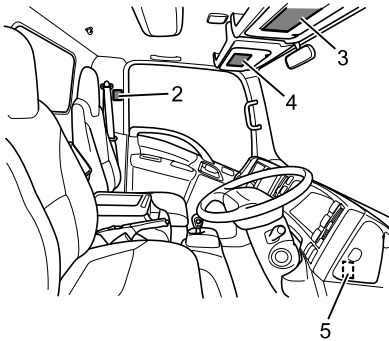
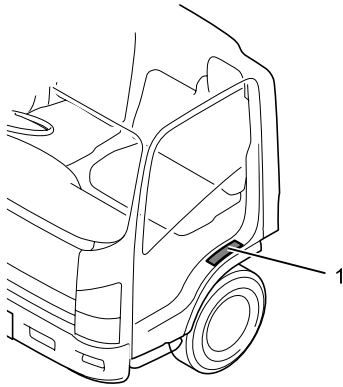

No.	Description
1	Cab tilt instruction (model with cab tilt system)
2	Engine periodic check
3	DPD, AMT, HSA, driver's SRS airbag, passenger's SRS airbag
4	Passenger's SRS airbag (model with passenger's SRS airbag)
5	Brake fluid
6	4WD - 2WD selection (4WD model)
7	Free wheel hub (4WD model)
8	Front propeller shaft lubrication (4WD model)
9	Engine maintenance lid (model with engine maintenance lid)
10	Fuse

Warning/Caution Labels – Fuel Tank

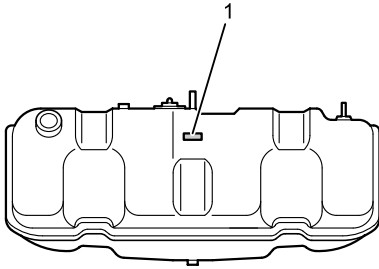

No.	Description
1	Diesel fuel (model with 63-liter fuel tank only)

Warning/Caution Labels – Engine Compartment

4JJ1 engine

4HK1 engine

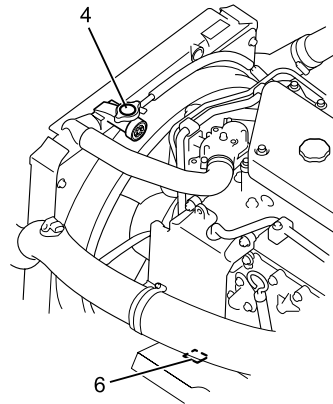
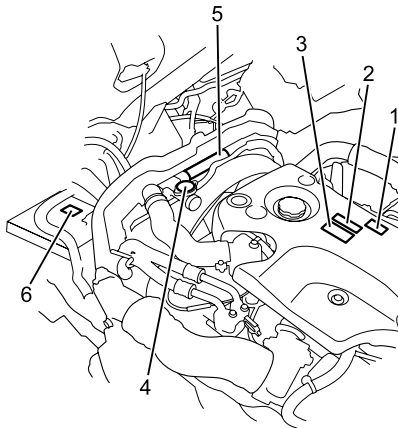

No.	Description
1	Engine oil level check (4JJ1 engine)
2	Fuel Filter Element (4JJ1 engine)
3	Engine oil (4JJ1 engine)
4	Radiator cap
5	Engine coolant (4JJ1 engine)
6	Engine control module

VEHICLE INFORMATION

1

• Chassis Number	1-2
• Vehicle Identification Number	1-3
• Engine Number	1-5
• Change of Ownership or Address	1-6

Chassis and Engine Numbers

The chassis and engine numbers are necessary for registering your vehicle. They are also necessary when your vehicle undergoes official inspections. Provide your Isuzu Dealer with these numbers when you are having the vehicle repaired or are ordering replacement parts. The Dealer will be able to do the requested jobs more competently and quickly.

Chassis Number

Chassis number location on frame

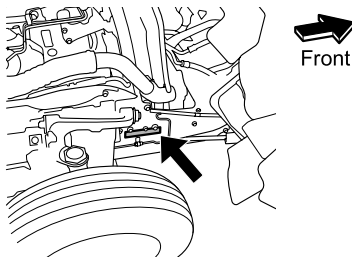

The chassis number is stamped on the right-side front part of the frame.

ID plate

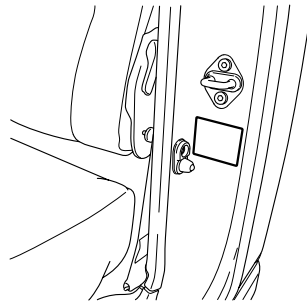

The ID plate at the lower part of the left-hand door striker indicates the chassis number together with other information such as the vehicle model code.



ADVICE

- The location of the ID plate may differ depending on the market. For further details, ask your Isuzu Dealer.

Vehicle Identification Number (VIN)

The ID plate indicates the VIN.

This single number contains multiple pieces of information including the vehicle and engine model codes as shown below.

J	A	A	N	L	R	8	5	E	8	7	1	0	0	0	0	1
1	2		3	4	5											6

Section	Description
1	World Manufacturer Identifier (WMI)
2	Vehicle model code NLR : 4 × 2 truck NLR model NNR : 4 × 2 truck NNR model NPR : 4 × 2 truck NPR model N1R : 4 × 2 truck NQR model NPS : 4 × 4 truck NPS model
3	Engine code 75: 4HK1 Engine 85: 4JJ1 Engine
4	Wheelbase code
5	Model year code 8: 2008 model
6	Production sequential number



ADVICE

- Interpretation of the VIN may differ depending on the market. For further details, please ask your Isuzu Dealer.

Option Codes

The ID plate also indicates option codes. These codes are three-digit, alphanumeric codes, each assigned to a particular component of the vehicle.

You will be able to use these codes to identify the model or type of engine, transmission, rear axle or other components when your vehicle needs inspection and other services.

Option Codes	Engine
LFB	4JJ1
RDQ	4HK1
RJS	

Option Codes	Transmission
RSF	MZZ6U
RSM	MYY5T
RSR	MZZ6F
RST	MYY6S

Option Codes	Rear axle
G73	Heavy-duty ϕ 292 mm
6CP	Heavy-duty ϕ 320 mm

Option Codes	Other components
6QN	Alternator 24V-50A
7YN	Alternator 24V-80A
8GF	With AMT
8GJ	Without AMT
6WC	PTO with lever
7GR	PTO with switch
8JM	DPD



ADVICE

- There are more option codes than those indicated above. Depending on the market, an option code may not be shown. For detailed specifications of your vehicle, please ask your Isuzu Dealer.

Engine Number

4JJ1 engine

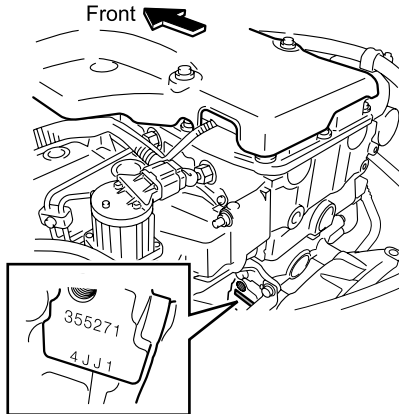

The engine number is stamped on the left-side rear part of the engine block.

4HK1 engine

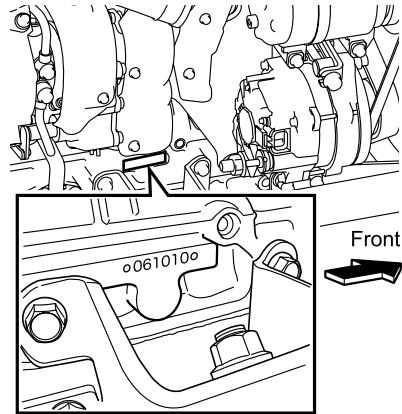

The engine number is stamped on the right-side front part of the engine block.

Change of Ownership or Address

It is requested that owner's who change their address (or name) or subsequent owner's who purchase this vehicle, copy and complete this form and return by mail, to the address shown.

This notification is important even after the expiration of the original vehicle warranty in order that you can be contacted if the need arises.

NOTICE OF NAME / ADDRESS / OWNERSHIP CHANGE

Owner's Name:

Business Name:

Address:

City / Town:

State: Postcode:

Business Phone: Private Phone:

Mobile: Email:

Registration Number:

Isuzu Truck Model:

Vehicle Identification Number:

Sold To Date:

Copy this form and mail to:
The Manager – Customer Care Department
Isuzu Australia Limited
GPO Box 107
Port Melbourne
Victoria 3207

• Warranty Statement	2-2
• Customer Assistance	2-10
• Before Driving	2-16
• Carrying Children	2-28
• Driving	2-30
• AMT Model <input type="checkbox"/> SA	2-41
• Four Wheel Drive (4WD) Model <input type="checkbox"/> V	2-44
• Stopping and Parking	2-47
• Staying Safe	2-53
• Preventing Breakdowns	2-56
• When to Visit Your Isuzu Dealer	2-58
• Diesel Particulate Defuser (DPD)	2-60
• Model with Speed Limit Device <input type="checkbox"/> V	2-63
• Seat Belt with Pretensioner and SRS Airbag System <input type="checkbox"/> V	2-64
• Vehicle Data Collection	2-67

This chapter contains information and cautions that you should observe for safe and comfortable vehicle operation. Be sure to read it before using the vehicle.

Warranty Statement

New Vehicle Warranty

New vehicle warranty application

This warranty is given by Isuzu Australia Limited, ABN 97 006 962 572 ("IAL"). The warranty applies to the Isuzu truck identified in your Owner's Manual. It is provided to the original and subsequent owner/operators driving the vehicle within Australia during the warranty Period (see table below). This warranty is given in addition to all rights conferred by law on that person.

Australian vehicles

This warranty is only applicable to vehicles purchased and operated in Australia. Owners of vehicles purchased in Australia but operated overseas should consult their local Isuzu Dealer in the country of operation about any warranty applicable to their vehicles. This warranty does not apply to Isuzu trucks exported overseas. Similarly, this warranty is not provided for vehicles purchased overseas and imported into Australia.

Repairs covered

Subject to the exclusions below, this warranty covers the correction, during the warranty period, of any vehicle defect in materials or workmanship and advised to an Isuzu dealer or IAL authorised service dealer, by repair or at IAL's option by replacement.

Warranty Period

The coverage commences from the earliest of the date of first registration or delivery. In the case of a demonstrator vehicle the date of commencement is when the vehicle was first placed into service by the dealer. The coverage expires at the end of the applicable period, engine hour's# or kilometres, as shown in this table, whichever occurs first.

ISUZU TRUCK MODEL	VEHICLE	ENGINE HOURS	CABIN PERFORATION CORROSION
NLR, NNR, NPR, NQR, NPS	3 years or 100,000 kilometres	2,000	3 years Unlimited kilometres

Engine hours are explained in the following paragraph.

Engine Hours

Where an hour-meter is not standard equipment, an engine hour-meter should be fitted. Fitment of an hour-meter is mandatory in applications with extended idling, stop-start operation, e.g. concrete pumpers, crane trucks, etc. If an engine hour meter is not

fitted, engine hours are an approximate calculation depending on distance travelled and the type of operation. As an approximate guide only, 5,000 kilometres is equivalent to 100 hours of highway operation or 150 hours of suburban operation. In certain circumstances, extended periods of engine operation when a vehicle is stationary can cause excessive wear, and this warranty excludes such wear. IAL reserves the right to exclude any claim under this warranty because of, but not limited to, excessive engine wear under such circumstances, or if the vehicle is not properly maintained within the prescribed service intervals as set out in your owner's manual, or if fitted, the hour-meter is inaccurate or defective in any way.

No charge

Subject to any exclusions, warranty work accepted by IAL and undertaken (including parts and labour) will be carried out at no cost to the owner/operators. However, this work should not be confused with regular servicing specified in the maintenance schedule of this manual, for which a charge is payable. IAL reserves the right to refuse any claim under this Warranty on the grounds if it reasonably believes that a warranty exclusion applies or the vehicle was used in an application that has caused excessive wear and tear.

Warranty Exclusions

Damage - Your warranty does not extend to the following causes of damage:

- Damage caused by an accident, fire, theft or objects striking the vehicle.
- Damage or corrosion caused by industrial fallout, lubricants, chemicals or sealants.
- Damage or corrosion caused by atmospheric or environmental fallout or flood, hail, salt, stone, windstorm, etc.

Maintenance items - Items such as brake/clutch adjustment, gear shift cable adjustment, replacement of filters, wiper rubbers, fluid replenishment, hoses, pipes, fuses, relays, globes, brake cylinders / chambers, suspension springs / bushes / pins / shock absorbers, driveline universal joints, steering joints, etc., which are required as part of normal vehicle maintenance. Refer to the maintenance schedule for these items.

Tyres - The tyres (and tubes where applicable) fitted to your vehicle are not covered by this warranty. However, they may be covered by the tyre manufacturer.

Batteries - Batteries are warranted for 12 months.

Misuse - The warranty does not cover damaged caused by:

- Misuse or abuse of the vehicle including but not limited to racing, overloading, etc., or neglect.
- Where component life is reduced due to application or environment – mining, logging, off-road, road-sweeper, tipper, towing, refuse, motor-home, agitator, crane, change of vehicle category, high centre of gravity, etc.
- Operation of the vehicle after it is known to be defective.
- Failure to carry out proper maintenance service in accordance with prescribed service intervals as set out in the maintenance schedule.
- Failure of the vehicle, engine or of any component due to contamination and/or use of incorrect types and grades of fuel, oil, coolant or lubricants.
- Alteration or modification of the vehicle by any party not authorised by IAL.
- Failure to mount body/equipment in accordance with IAL recommendations.
- Any fault caused by fitment of bodies and/or body mountings that do not conform to the IAL Body Builders Guide. This document is available on request from IAL.
- The fitting of parts or accessories not approved by IAL or conforming to IAL's specifications.
- Cosmetic or surface corrosion resulting from scratches, stone chips, etc.
- Any work carried out on the vehicle by someone other than an authorised Isuzu truck dealer or authorised service dealer.
- Deterioration due to normal use, exposure, wear and tear.
- Operating the vehicle in circumstances where the prescribed engine hour's service interval has been exceeded without proper maintenance causing excessive engine wear.

Excluded from Vehicle Warranty

Defects in tyres (warranted by their manufacturer), batteries (warranted for 12 months), wheel alignments, brake and clutch linings, and any items that require replacement as part of normal vehicle maintenance.

Parts and Accessories Warranty

IAL warrants IAL approved Parts and Accessories ("Parts" and "Accessories") for the periods and on the conditions set out below. The warranty covers the correction, during the relevant warranty period, of defects in any such Parts and Accessories, by repair or at IAL's option by replacement.

Accessories installed to the new vehicle

IAL approved Accessories installed by an Isuzu dealer or IAL authorised service dealer to the new vehicle, at the time of purchase, are covered by the vehicle warranty.

Parts and Accessories installed after new vehicle delivery by an Isuzu Dealer or IAL Authorised Service Dealer

Parts and Accessories installed after delivery by an Isuzu dealer or IAL authorised service dealer, and the workmanship involved, are covered according to the following;

N Series; 36 months or 100,000 kilometres whichever occurs first from the date of purchase.

Parts and Accessories purchased at retail or trade

Parts and Accessories purchased at trade or retail and installed by other than an Isuzu dealer or IAL authorised service dealer are warranted for 12 months from the date of purchase. This warranty does not cover labour costs of removal or reinstallation of Parts and Accessories when installed or rectified by other than an Isuzu dealer or IAL authorised service dealer.

Parts and Accessories not conforming to IAL specification

Any parts or accessories not approved by IAL, or not conforming to IAL specifications and all costs in connection such with the fitting, removal, installation or reinstallation of such parts and accessories are not covered by this Warranty.

Parts and Accessories purchased for Applications other than their intended use

If the Parts or Accessories are used in an application other than was designed or intended by IAL, no warranty will apply unless otherwise advised in writing prior by IAL.

Parts and accessories warranty exclusions

The tyres (and tubes where applicable) are not covered by this Warranty. However, they may be covered by the manufacturer. Batteries are warranted for 12 months from date of purchase. Parts which are required as part of normal vehicle maintenance, are warranted against manufacturing defect at the time of installation.

Warranty Questions

This section is designed to assist you in understanding the IAL Warranty provided with your new Isuzu vehicle.

The following are some of the most frequently asked questions, for which detailed answers have been provided.

Q 1. How do I go about obtaining IAL Warranty Service?

It is the responsibility of the selling Isuzu dealer to provide IAL Warranty service; therefore you should take your vehicle to the dealer whenever IAL Warranty service is needed. However, if this is not possible, you may go to any other Isuzu dealer who will require the details recorded inside this owner's manual.

Q 2. What should I do if my Vehicle becomes unsafe or inoperative as a result of a defect which is covered by the IAL new vehicle warranty?

You should contact the nearest Isuzu dealer or IAL (refer further in this chapter) as soon as possible, and arrange for that dealer to carry out the required IAL warranty service.

Q 3. What should I do if, in an emergency the vehicle is unsafe, and, IAL warranty service is required and an authorised Isuzu dealer is not available to provide such service at the time?

Under no circumstances should you operate the vehicle whilst it is unsafe. If, in an emergency, a repair, replacement or adjustment (covered by the IAL new vehicle warranty) is required to enable the vehicle to be operated safely and it is not practical for you to go to an Isuzu dealer, the service (but only to the extent that it is necessary to enable the vehicle to be operated safely) may be performed by any other qualified mechanic or repairer. A claim for the reasonable cost may be made through the Isuzu dealer who would normally provide you with an IAL warranty service. You must also take your vehicle to the authorised Isuzu dealer for inspection of the service and/or completion of any required IAL warranty service, as soon as possible.

(Note: During normal business hours you should seek authorisation from your nearest Isuzu dealer or IAL prior to repairs being commenced.)

Q 4. Are damage or injury, loss of time, inconvenience, commercial or other direct or indirect loss covered by the IAL warranty?

No, these items are not covered. The IAL warranty only covers the repair, replacement or adjustment of those parts of your vehicle, which are found to have a manufacturing defect in materials or workmanship. No other types of claim for compensation of any kind, even if the loss resulted from a consequence of a defect in materials or workmanship in your vehicle, will be recognised under the IAL warranty. You may have rights under the law to claim compensation outside of the IAL warranty, but any claim based on those rights should be separately pursued.

Q 5. Will I have to pay for maintenance costs during the warranty Period?

Maintenance costs are not covered by the IAL warranty. The maintenance schedule in this owner's manual specify the minimum maintenance required for your vehicle operating under normal conditions. Any maintenance on the vehicle should be validated in the maintenance schedule by being accurately completed, signed and stamped by the dealer to show that proper maintenance on the vehicle has been carried out.

The maintenance items below are subject to normal wear and tear (unless because of manufacturing defects in materials or workmanship) for which you will have to pay for include:

- Clutch facings
- Injector/injector nozzle replacement.
- Replacement of all filters.
- Cleaning or flushing of fuel, coolant, brake, engine, transmission, differential, power steering etc., after 5,000 km.
- Adding to (or replacing) lubricants
- Adding to (or replacing) air conditioning refrigerant, after 5,000 km.
- Any necessary adjustments to drive belts, transmissions, clutch, park brake, etc.
- Wheel balancing after 5,000 km
- Wheel alignment. (front & rear)
- De dusting or de glazing of brake linings or pads after 5,000 km.
- Brake lining wear or damage.
- Brake pad, drum or disc wear.
- Battery re charging.
- Paint, bright metal finish and trim, due to normal deterioration.
- Body panel adjustment after 5,000 km
- Door or bonnet lock adjustments.
- Glass or channel adjustments after 5,000 km.
- Body rattles, squeaks and general tightening of bolts, fastenings and fittings after 5,000 km.
- Chipped glass or breakage – repair or replacement.
- Torn or damaged floor mats or carpets.
- Engine tune-ups, ignition components, spark plugs, glow plugs, fuses, globes and wiper blades.

Q 6. Are my tyres covered by the IAL New Vehicle warranty?

No. The tyres fitted to your vehicle are covered by a separate warranty provided by the tyre manufacturer. Any authorised Isuzu dealer will assist you by discussing queries that you might have with respect to the tyre manufacturer's warranty with the respective representative.

Q 7. Will I have to pay for any costs or expenses in connection with the provision of IAL warranty service?

All parts and labour used in carrying out IAL warranty service at the premises of the servicing Isuzu dealer are free of charge. Whenever IAL warranty service is to be carried out by an Isuzu dealer it is your responsibility and cost to deliver the Vehicle to the servicing Isuzu dealer's premises.

Q 8. Would my vehicle's engine benefit from fuel, oil or coolant additives not marketed by IAL?

The use of break in oil, tune up compounds, friction reducing compounds and other supplemental additives is not recommended: their use will not only increase operating costs, but may also be detrimental to the operation of your vehicle. Only the fluids and lubricants referred to in your owner's manual should be used.

UNAUTHORISED STATEMENTS IN RELATION TO IAL's PRODUCTS

Subject to any relevant laws, this warranty contains all of IAL's obligations to you in relation to the vehicle.

No Isuzu dealer or other person is authorised or permitted to give or make any statement, assertion or undertaking in relation to the quality, performance, characteristics, descriptions or fitness for any purpose of any IAL product or in connection with the supply of any IAL product, which is at variance with any written statement, assertion or undertaking on any of these subjects given or made by IAL in its published sales literature, and IAL does not accept any such unauthorised act.

**CAUTION OVERLOADING**

The components of your truck are designed to provide satisfactory service if the vehicle is not loaded in excess of either the gross vehicle mass rating or gross vehicle weight rating (GVM or GVW), gross combination mass rating or gross combination weight rating (GCM or GCW) or the maximum front and rear gross axle weight rating (GAW). Refer to the vehicle identification plates for the vehicle weight ratings.

Overloading can result in loss of vehicle control and personal injury, either by causing component failures or by affecting vehicle handling. It can also shorten the service life of your vehicle.

MAXIMUM FRONT AND REAR AXLE WEIGHTS

The weight of the cargo load must be properly distributed over both the front and rear axles. The GVM or GVW rating is the maximum permissible loaded weight of the vehicle and takes into account the capabilities of the engine, transmission, frame, springs, brakes, axles, and tyres.

For maximum stability and safety, the cargo load should be distributed on both sides of the truck centre line as equally as possible.

Scheduled Maintenance

NORMAL VEHICLE USE - The maintenance schedule in this section are based on the assumption that your vehicle will be used as designed:

To carry passengers and cargo with the limitations indicated on the two vehicle identification plates affixed to every vehicle. On reasonable road surfaces within legal operating limits for at least several hours or kilometres and as a general rule, on a daily basis.

SEVERE VEHICLE USE - Operating conditions, such as driving in dusty areas, sweeper, agitator, agricultural, off-road vehicles, extended idling, refrigeration vehicles, refuse vehicles, mining, logging, etc., or vehicles operated for frequent short trips, will require more frequent vehicle maintenance in accordance with the severe operating maintenance schedule in this section.

PREVENTATIVE MAINTENANCE - As with any mechanical device in operation, a certain amount of wear occurs. The amount of wear depends on certain variables – type and method of operation or application and the schedule of maintenance.

For example, if a vehicle is repeatedly overloaded, driven at excessive speed or improperly shifted, no schedule of maintenance can prevent component failure. Also, if preventive maintenance schedule is not followed, or is improperly carried out, no amount of correct vehicle operation will prevent component failure.



NOTE

If vehicle application, operation and preventive maintenance schedules and procedures are followed accordingly to IAL's recommendations, the life of the vehicle will be greatly extended.

For example, regular attention to the engine oil is essential. The oil level must be checked daily and oil added whenever needed. Also, the oil should be changed at the intervals specified with the proper quality and viscosity of oil. If your engine should run excessively low on oil or if the oil has lost its lubricating qualities because of old age, serious engine damage could occur that is not be covered under the new vehicle warranty.

Customer Assistance

We trust that you are delighted with your Isuzu truck and that it provides you with many years of safe and trouble free operation.

However, in the event that you experience a problem with any aspect of your vehicle, be assured your Isuzu Dealer is well equipped to assist you.

If for any reason you are unable to obtain satisfaction through your Isuzu Dealer, please contact us on the Isuzu Customer Care toll free line;

1800 035 640

To assist us in helping you please provide the following details when calling;

- Your name and address
- Contact telephone numbers
- Your Isuzu Dealers name and address
- Vehicle model
- Vehicle identification number (I.S.O.V.I.N.)
- Date of purchase
- Current odometer reading

Most of this information will be found on the Vehicle Identification Certificate, located inside this Handbook.

Again, we wish you happy and safe operation of your vehicle.

24 Hour Roadside Assistance

From the moment you take delivery of your new Isuzu truck/s, our aim is to provide you with the finest ownership experience, beginning with superior design and manufacturing and continuing through Dealer servicing and then beyond to the open road. Our range of Isuzu trucks, are built to exacting standards and undergo stringent quality checks throughout the manufacturing process to ensure our valued customers consistent reliability. There are however a number of reasons, apart from mechanical breakdown, why your journey could be interrupted, including:

- Running out of diesel fuel
- Flat tyre/s
- Flat battery
- Lockout or lost keys
- Glass repair
- Hydraulic hose repair

Isuzu Assist covers you at the roadside 24 hours a day, 365 days a year for 36 months from the date of first registration. This free service is extended to you whether you are a private truck purchaser, a fleet, taxi truck or rental company, or a Commonwealth, State or Local Government customer.

Isuzu Assist is delivered throughout Australia from a highly trained team of technicians and recovery operators. Whatever the reason, it's reassuring to know that Isuzu Assist is only a phone call away.

For Roadside Assistance, dial the free service line;

1800 947 898

Being Prepared

If you have the following information available before you call, it will help us to provide you with a more efficient service.

1. Your truck registration number and VIN number.
2. The model and year of your truck,
3. The nature of the problem.
4. The exact location of your truck, the state, city and town, suburb or area, street or road and the nearest corner, crossroad and landmark if applicable.
5. Whether your truck is laden and if so, what is the approximate GVM.

The truck Vehicle Identification Number is on the vehicle ID plate.

Isuzu Assist - Unlimited Calls

You are entitled to unlimited calls for roadside assistance covering:

Mechanical Breakdown

Isuzu Assist will despatch an emergency roadside service provider whose aim is to get you mobile with a minimum of fuss.

Out of Fuel

Wherever possible, Isuzu Assist will provide sufficient diesel fuel to enable a truck that has run out of fuel to be driven to the nearest diesel supply facility (the immediate supply of fuel may be charged to the Driver).

Where it is not possible or practical to provide diesel fuel, a tow will be provided to the nearest facility.

Tyre / Wheel Changing

Isuzu Assist will help the driver replace a damaged tyre/wheel using the trucks original equipment.

Where the original equipment is not serviceable, roadworthy or compatible, a tyre service may be dispatched to assist.

All materials and any additional labour charges must be paid for at the time of the service.

Where this is not possible a tow to the nearest facility that is able to supply and/or repair the tyre/wheel combination will be provided.

Flat Battery

An Isuzu Assist service provider will attempt a battery boost to start your truck.

If the original battery is found to be faulty and is still inside the term of the battery warranty period, a replacement battery may be arranged at the roadside and installed.

If the faulty battery is outside the term of the warranty period, a replacement battery may be supplied and installed.

However, all materials and any additional labour charges must be paid for at the time of service.

Lockout or lost keys

If you have lost your keys, or inadvertently locked them in your truck cabin, Isuzu Assist will attempt to open the truck.

However, the driver may be asked to sign an indemnity releasing the service provider from any liability should damage be caused by such forced entry.

Alternatively, Isuzu Assist will arrange if possible, for a locksmith to attend at the driver's expense.

The driver would be responsible for any costs over \$50 (inclusive of GST) per case.

Glass Repair Services

Isuzu Assist will provide the driver with an emergency glass service and/or replacement part.

Any parts or additional labour charges not covered under Isuzu's warranty program must be paid for at the time of service.

Hydraulic Hose Repair Services

Isuzu Assist will provide the driver with a hydraulic hose service and/or replacement part/s.

Any parts or additional labour charges not covered under Isuzu's warranty program must be paid for at the time of service.

Message Relay

Isuzu Assist will relay any messages from the driver.

In the event of a breakdown, Isuzu Assist can relay messages to family members, friends or business associates so as to notify them of any possible delays.

Interpreter Service

An interpreter will be brought on line should the driver need assistance in communicating their details to Isuzu Assist.

Towing

In the event we are unable to get you mobile, we will arrange towing.

(Refer Conditions of Supply 'Towing')

1. Your truck will be towed to the nearest Isuzu Truck Dealer. Should the breakdown occur out of normal business hours, your truck will be stored and delivered to the nearest Isuzu Truck Dealer as soon as is practicable.
2. Caravans and/or any form of registered trailer that is in tow at the time of the service callout, will be transported at the driver's expense to the same destination as the towed truck.
3. Alternatively, the Driver may elect to have the truck towed to an alternate destination. However, the driver must agree to accept any additional towing costs incurred, over and above the Isuzu Assist towing allowance.

Accident Co-ordination

Isuzu Assist with the assistance of the driver will proceed in the management of the incident.

This could include advising the driver of their obligations at the scene of the accident, connecting the driver to an appropriate Service Provider, 000 Emergency services, or a vehicle recovery operator.

Isuzu Assist will remain on the line to ensure appropriate services are being provided.

Conditions of Supply - Eligible Isuzu Trucks

The truck must be roadworthy and registered within the first six (6) months of the purchase date.

Isuzu Assist services can be provided to ineligible trucks at the driver's expense.

Service Costs

Isuzu Assist covers all eligible Isuzu Trucks from home, business or the roadside, for everything except diesel fuel assistance above that specified on page 2-12, or parts not covered under warranty. For parts ineligible under Isuzu's warranty programme, the driver will be responsible for any costs at the time of supply.

**NOTE**

You hereby authorise NTI TRUCKASSIST to charge your credit card for any non-covered expenses in excess of the limits set out below and any costs in excess of the coverage benefits.

The credit card number provided to NTI TRUCKASSIST will be charged for any costs in excess of the covered benefits.

Towing

Table 1

* GST inclusive limit	NLR, NNR, NPR, NQR, NPS.
	\$300*

Towing is provided to a maximum value per tow as outlined in Table 1 throughout the 36 months of free cover, commencing from the date of first registration of the truck. In all cases, the decision regarding whether a vehicle requires towing rests solely with the Isuzu Assist service provider.

Excess costs will be charged to the driver at the conclusion of each towing service. The driver must agree to accept any specific excess towing charges prior to the tow being undertaken.

Trafficable Roads

Service can only be provided to qualifying Isuzu trucks, on a constructed road/driveway that is legally trafficable by a conventional two wheel drive vehicle and/or towing recovery vehicle.

Bogged Trucks

If your truck becomes bogged on a road which is considered to be legally trafficable to normal two wheel drive vehicles and where no special equipment is required Isuzu Assist will be provided.

Truck Rescue

If your truck has become disabled off a 'legally' trafficable road in a situation such as a beach, field or creek bed, Isuzu Assist will attempt truck rescue, however, this will be at the driver's expense.

Remote Areas

In remote or sparsely populated areas you may experience delays in obtaining Isuzu Assist due to your location, the availability of the service provider and accessibility.

**NOTE**

Remote areas are defined as areas within Australia that are sparsely populated and where normal dealer services are not readily available.

Attempted Repairs

If you request Isuzu Assist, the service provider will on arrival examine the truck. If it is found that a third party has attempted repairs causing further problems and the service provider considers in his/her opinion that the truck cannot be started or driven without risk of further damage, service may be refused. In these circumstances the owner/driver will be responsible for any towing costs incurred.

Unattended Trucks

It is imperative that the driver, or a representative, wait with the truck until the service provider arrives unless previous arrangements have been made and agreed to by the attending service provider. Unattended trucks will not be serviced under any circumstances. Where the owner/driver has elected an authorised representative, the representative must hold a current and appropriate truck driver's licence in case the truck is required to be moved. Where the truck is found to be unattended, any subsequent calls for assistance may be at the driver's expense.

Special Equipment

If the service provider is required to return to their service facility to collect any special equipment required to deliver effective service, the additional cost will be the owner/driver's responsibility.

Natural Disasters

If a natural disaster places extraordinary demands on service resources, Isuzu Assist may alter and/or offer alternative service. If a disabled truck cannot be reached owing to events such as floods or bushfires, Isuzu Assist will endeavour to provide whatever assistance is practicable under the circumstances.

Damage during Service

If you believe your truck has been damaged by a service person providing roadside assistance, you should contact Isuzu Assist on 1800 947 898. The truck in question must be inspected by a person authorised by Isuzu and agreement gained prior to any further repairs being undertaken.

**NOTE****Owner / Driver**

Isuzu Truck owners requiring assistance for a flat tyre and/or damaged rim, may be requested to assist the service provider at the roadside due to the combined weight of the tyre/wheel combination.

Cargo

Isuzu Australia Limited, National Transport Insurance Limited and their service providers will accept no responsibility under any circumstances, for the security, loss or any damage of cargo carried by a disabled truck.

General Customer Comments

Please direct any comments or concerns regarding the Isuzu Assist program and/or the service/s provided, to our Customer Care Centre on 1800 035 640.

**NOTE**

Isuzu reserves the right to change the service provider's conditions and supply procedures outlined in this booklet, without notice.

Privacy Policy

For information on the Isuzu Australia Limited privacy policy, please visit www.isuzu.com.au or call the Isuzu Customer Care Centre on 1800 035 640.

Service provided by NTI TRUCKASSIST

Before Driving

Perform Daily (Pre-operation) Inspections

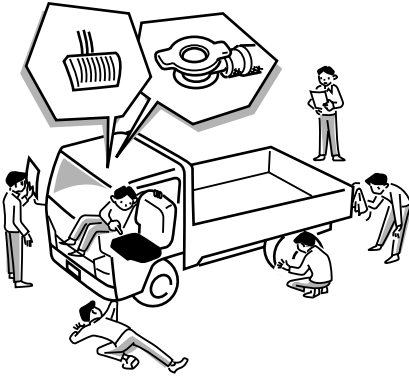

ADVICE

- For safe and comfortable driving, keep record of the distances driven and the condition of the vehicle during operation. Perform inspections at appropriate intervals, and perform maintenance in accordance with the findings of the inspections. If an inspection reveals an abnormality or there was an abnormality the previous time the vehicle was driven, have the vehicle repaired by the nearest Isuzu Dealer before it is driven again.

[1. Checking components that showed abnormalities during the previous operation]

Check item	Reference page
Checking components that showed abnormalities during the previous operation	7-17

[2. Checks performed with the engine inspection hatch opened or cab tilted]

Check item	Reference page
Fan belt looseness and damage	7-44
Engine oil level	7-22
Engine coolant level	7-34
Power steering fluid level	7-120

[3. Checks performed in the driver's seat]

Check item	Reference page
Brake fluid level (and clutch fluid level <input type="checkbox"/> M/T)	7-62 (7-100)
Brake pedal free play	7-70
Clutch pedal free play <input type="checkbox"/> M/T	7-104
Operation of meters, gauges and warning/indicator lights	4-7, 4-15
Engine startability, abnormal noise and color of exhaust gases	7-20
Parking brake lever stroke	7-72
Windshield washer fluid spray condition and windshield wiper effectiveness	7-133, 7-134
Windshield washer fluid level	7-133
Steering wheel position and free play	3-21
Operation of horn and turn signal lights	4-73, 4-65
Fuel level	4-13
Operation of door locks	3-4

[4. Checks performed during a walk around the vehicle]

Check item	Reference page
Illumination, flashing or for stained or damaged lights	7-137
Battery fluid level	7-141
Leaf spring damage	—
Leakage of oil, coolant, fuel, brake fluid, power steering fluid and HBB oil.	—
Water collecting in the fuel filter (bottom)	7-53

[5. Checking wheels and tyres]

Check item	Reference page
Air pressure	7-81
Cracks and other damage	7-83
Abnormal wear	7-83
Tread depth	7-83
Disc wheel mounting condition	7-84

[6. Checks performed while driving]

Check item	Reference page
Brake effectiveness	7-71
Checking the engine at low speeds and during acceleration	7-21

Use the Specified Fuel

**CAUTION**

- Always use only a low-sulfur diesel fuel (50 ppm or lower sulfur content) or super-low-sulfur diesel fuel (10 ppm or lower sulfur content). The use of a poor-quality diesel fuel, mixing such an additive as water remover to the fuel in the tank, or filling the tank with gasoline, kerosene or an alcohol-based fuel or its mixture with a diesel fuel will badly affect the fuel filter and result in lubrication problems in fuel-lubricated components of the injectors. In addition, this practice can also impair the operation of the engine and the diesel particulate defuser (DPD), the exhaust emission cleaning system, possibly leading to breakdown of the engine-related systems. If an incorrect fuel should accidentally be added, drain all fuel from the system. Failure to observe this precaution can result in a fire or permanent damage when the engine is started.
- The use of any fuel other than a low-sulfur or super-low-sulfur diesel fuel in a DPD-equipped vehicle may violate the relevant regulations enforced in certain countries or regions.
- Open the fuel tank filler cap slowly. If you open it quickly, fuel may spurt out.

**NOTE**

- The specifications of diesel fuel differ according to the season and region.

Fuel Tank Filler Cap

→ Refer to page 3-13

Fuel

→ Refer to page 6-19

Using Self-service Filling Stations

WARNING

[Be sure to obey the following instructions when refueling the vehicle]

- Stop the engine and close the vehicle's doors and windows.
- Keep cigarettes and other flames away from the vehicle.
- Before opening the fuel tank filler cap, touch a metallic object to discharge static electricity from your body. If you have a static charge buildup on your body while refueling the vehicle, a spark caused by its discharge could ignite the fuel, resulting in burns.
- When refueling the vehicle, keep the nozzle pushed fully into the filler neck. Trying to add more fuel by pumping fuel with the nozzle partially withdrawn is dangerous because the auto-stop mechanism may not work, resulting in an overflow of fuel.
- All parts of the refueling procedure (from opening the fuel tank filler cap to completing the refueling and closing the fuel tank filler cap) must be performed by the same person.
Other people may be carrying static electricity. Do not allow them to approach the fuel filler.
The person performing the refueling procedure must not return to the seat in the cab part-way through the procedure. He/she could pick up another charge of static electricity by doing so.
- Do not use any fuel tank filler cap that is not an Isuzu genuine part.
- Obey all cautions posted in filling stations.

CAUTION

[Caution when refueling the vehicle]

- Be careful not to inhale fuel vapor when refueling the vehicle.

Fuel Tank Filler Cap → Refer to page 3-13



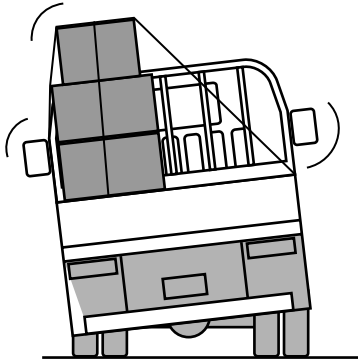

Load Cargo Correctly

**WARNING**

- Overloading can result in an accident because it places too much strain on the wheel studs with the result that they break and the wheels come off.

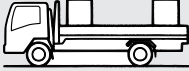
**CAUTION**

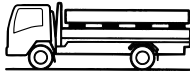
- It is extremely dangerous to overload the vehicle or to load the vehicle with the cargo positioned on one side. Load the vehicle correctly, observing the maximum loading capacity.
- Incorrect loading can make the cargo unstable. It can also cause an overload condition confined to a small area, resulting in damage to the cargo bed and frame.
- Overloading places undue strain on vehicle parts. It can shorten the vehicle's service life and cause an accident.

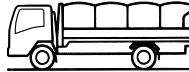
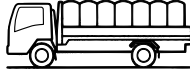
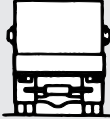
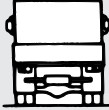
Cargo loading caution	Incorrect	Correct
Do not place cargo only at the front or only at the rear. Distribute it evenly.		
When using supports under cargo, position them uniformly along the cargo.		
To the greatest extent possible, do not allow long cargo to protrude beyond the rear edge of the cargo bed. Rather, use supports to raise it at an angle. Avoid supporting it using just the front guard frame and the rear edge of the cargo bed.		
Use ropes and tarpaulins to secure the cargo so it does not fall off the cargo bed. Use rubber bands or bungee cords to prevent the tarpaulins from flapping in the wind.		
Avoid loading cargo too high. It can cause the vehicle to tip sideways when it catches sidewinds and when turning the vehicle.		

Loading Heavy Cargo

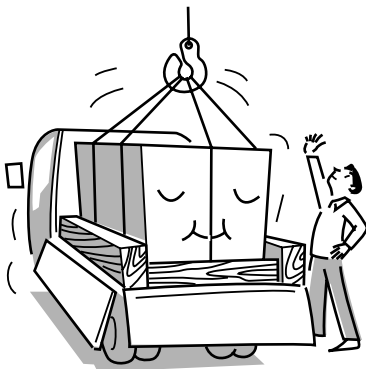

CAUTION

- When the cargo is heavy, take steps to prevent it from slipping and secure it with wire cables.

Do Not Secure Cargo Too Tightly



ADVICE

- To prevent cargo from falling off the cargo bed, it is essential to secure it with ropes and tarpaulins. However, securing it too tightly can damage the cargo bed's gates and front guard frame.

Make Sure There is No Flammable Material between the Cab and Cargo Bed

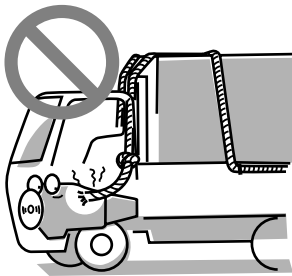

WARNING

- Be careful not to allow the ends of ropes or edges of tarpaulins to come lower than the heat protector at the back of the cab. During vehicle operation, the engine's heat could set them on fire. Carefully secure the ends of ropes and edges of tarpaulins.

Economical Driving

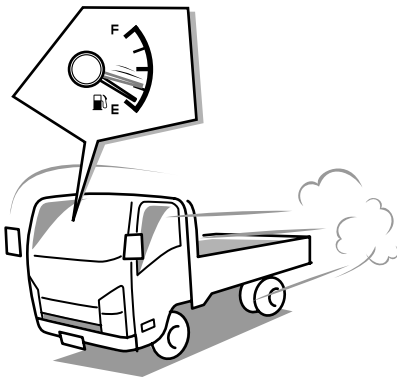

Driving too fast, driving so slowly that the engine knocks, driving with the exhaust brake switched on all the time, and frequently using the exhaust brake to adjust your speed can lead to poor fuel economy.

Drive at a constant speed as much as possible. When accelerating, increase your speed gently and slowly, and up-shift early.

Warming up the engine for longer than necessary and revving the engine are a waste of fuel. Driving with the vehicle overloaded is also a waste of fuel.

Frequently check the tyre pressures and make sure they are always correct.

Unloading Cargo

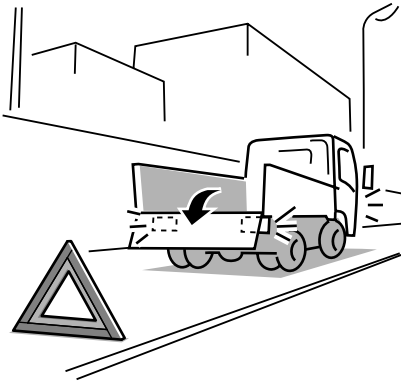

CAUTION

- When you load or unload cargo at the roadside and the cargo bed's gates or other body parts obscure the tail lights, stop lights, hazard warning flashers, turn signal lights and/or reflectors, be sure to warn other drivers and passersby by placing signs or emergency warning triangles where they are easy to see.
- When you load or unload cargo at the roadside, select a place where stopping and parking are allowed and other drivers and passersby will not be inconvenienced.

Do Not Carry Fuel and Spray Cans in the Cab



WARNING

- It is extremely dangerous to carry fuel and spray cans in the cab. If such a container were to ignite or rupture, it could cause a fire or explosion.

Using Curtains

CAUTION

- Retain the curtains so as not to obscure your view and hinder your driving.

Keep the Floor around the Driver's Seat Clean and Tidy**WARNING**

- It is extremely dangerous to have empty cans, empty bottles or other items rolling around on the floor because they could get trapped under the brake pedal and prevent brake application. For proper pedal operation, it is also essential to lay floor mats properly. Incorrectly installed floor mats would hinder free movement of the pedals.
- Do not use the dashboard pocket or the top of the dashboard as a place to put items that could roll, which could interfere with your driving.

Correct Driving Posture**WARNING**

- Before driving, be sure to adjust the seat, steering wheel and mirrors to positions that give you a correct driving posture. Make sure the seat is securely retained by trying to rock it forward and backward, and put on the seat belt. All other passengers must wear seat belts.

Seats → Refer to page 3-17
Seat Belts → Refer to page 3-23
Mirrors → Refer to page 3-22

Seat Adjustment

Adjusting the seat for a correct driving posture is a fundamental part of safe driving.

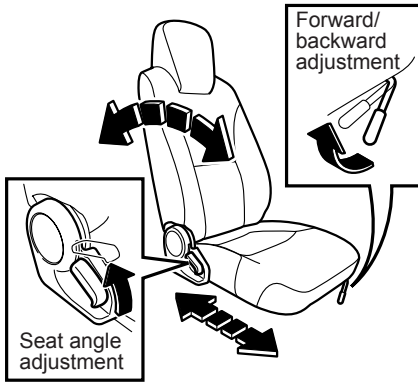

Fastening Your Seat Belt

Be sure to wear your seat belt. Sit up straight with your lower back pressed against the seat and the lap belt as low on your hips as possible.

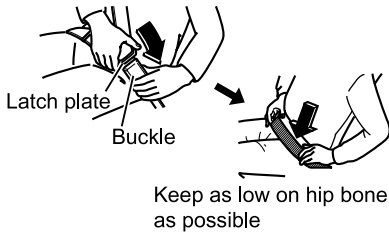

Seat adjustment recommendations	
a	Make adjustments that allow you to easily turn the steering wheel with your elbows slightly bent.
b	Position the seatback so it is always touching your shoulders.
c	Make sure you can adequately press each pedal.

Seat belt fastening cautions		Why?
A	Position the lap belt as low on your hips as possible.	The pressure applied by the seat belt in a collision would be dangerous if the belt is positioned incorrectly.
B	Position the shoulder belt so it is on your shoulder (not touching your neck, chin or face).	
C	Make sure the seat belt is not twisted when you put it on.	To ensure that the seat belt is fully effective.

Passengers and Seat Belts

Only one person at a time should use each seat belt.

WARNING

- Be sure to adjust the seat before driving. Achieve the correct driving posture, gently rock the seat to make sure it is locked in place, and put on your seat belt before you start driving. All passengers must wear seat belts.
- For a child who is so small that the seat belt touches his/her face or does not rest across his/her hips, use a child seat or other suitable restraint, not the seat belt. Using the seat belt could be dangerous.

Carrying Children → Refer to page 2-28

Adjusting the Position of the Steering Wheel

You can adjust the position of the steering wheel in the up-down and fore-aft directions. After making an adjustment, make sure the steering wheel and lock lever are securely locked.

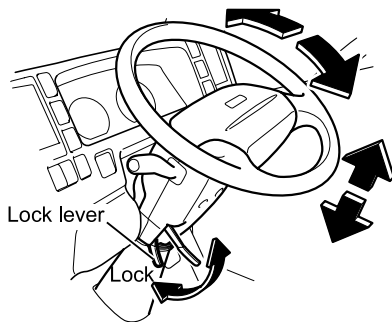

WARNING

- When you have adjusted the steering wheel, try pulling the steering wheel up and down to check that it is securely locked in position before driving.
- Adjust the position of the steering wheel before you start driving. Adjusting the position of the steering wheel while driving would be extremely dangerous because the steering wheel would rattle up and down, preventing precise steering.

Fully Adjustable Steering

→ Refer to page 3-21

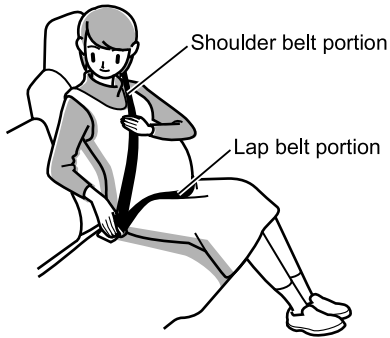
Carrying an Expecting Mother or a Person Who Is Ill**WARNING**

- An expectant mother or a person who is ill riding in the vehicle must also wear a seat belt. In light of the risk that the seat belt will apply pressure to the abdomen, chest and shoulders in the event of a collision, however, an expectant mother or person who is ill should get advice from a physician beforehand.
 - An expectant mother should use a three-point seat belt.
 - An expectant mother should position the lap belt snugly as low as possible on the hips (not across the abdomen). Also, she should fasten the shoulder belt so it rests on her chest, not on her abdomen.
 - Unless the seat belt is correctly worn, it may dig into the abdomen in the event of hard braking or a collision, harming not only the expectant mother but also the unborn child, putting them both in danger of serious injuries or death.

Seat Belts → Refer to page 3-23

Carrying Children

Using Seat Belts with Children

WARNING

- The vehicle's seat belts are designed for adults. If a seat belt touches a child's neck or chin, or does not rest across his/her hips, use a baby seat, child seat or junior seat. If the seat belt were used as it is, it could apply intense pressure to the child's abdomen in the event of a collision. A small child who is not able to sit up by him/herself must be placed in a child seat.
- Do not fit a baby seat, child seat or junior seat on the centre seat. It could hinder your driving.
- If the vehicle has a passenger airbag, do not fit a baby seat, child seat or junior seat facing rearward. If the baby seat, child seat or junior seat is facing rearward, the impact on the child seat during deployment of the passenger airbag could inflict life-threatening injuries on the child.

NOTE

- The appropriate type of baby seat, child seat or junior seat and the proper installation for it depend upon the weight and height of the child. It may not be possible to correctly fit certain child seats depending on their shapes. Be sure to use a child seat that is suitable for the vehicle.
* For detailed instructions, see the instruction manual supplied with the baby seat, child seat or junior seat.

Seat Belts → Refer to page 3-23

Do not Leave a Child Alone in the Vehicle

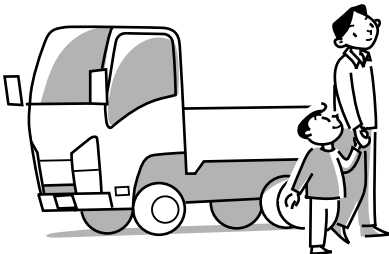

WARNING

- When you leave the vehicle, take the child with you. If you leave the child alone in the cab, the child could interfere with things, causing vehicle movement, a fire or some other accident. Also, the cab inside could become dangerously hot when heated by the sun.

Do not Allow a Child to Put His/Her Head or Hands Out of the Window

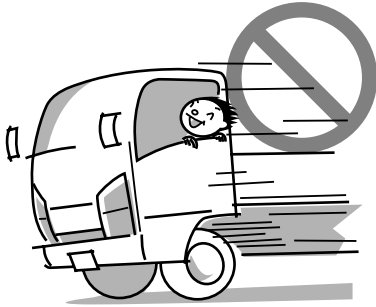

WARNING

- Regardless of whether the vehicle is moving or stationary, you must never allow a child to put his/her head, hands, or other body parts out of the window. Allowing such behavior would be dangerous because the child could hit an obstacle.

An Adult must Open, Close and Lock the Door for a Child

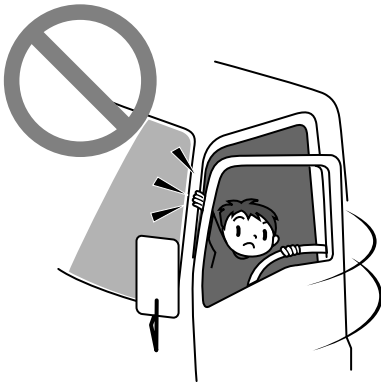

WARNING

- To protect the child from the danger of getting his/her hands and head trapped, an adult must open, close and lock the door for the child. Be careful that the child does not interfere with the power window switches and get his/her hands or head trapped in the window. While a child is in the cab, be sure to control the power windows using the power window switches beside the driver's seat.

Opening and Closing Doors

→ Refer to page 3-7

Power Windows

→ Refer to page 3-10

Driving

Check around the Vehicle before Starting the Engine

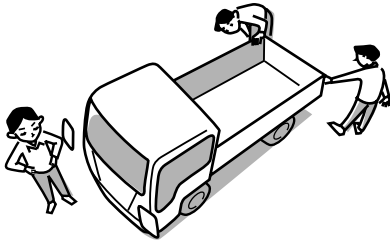

Before pulling away, perform a thorough safety check, making sure there are no children or obstructions around the vehicle.

WARNING

- Before starting the engine, make sure there is no flammable material under or around the vehicle. The presence of any such material could lead to a fire. If there is any wood within 50 cm (approximately 20 in) from the vehicle's heat source, it would represent a severe hazard as the wood could deform or discolor from the heat or it could catch fire.

Starting the Engine → Refer to page 4-4

Be Careful about Exhaust Emissions

WARNING

- Exhaust emissions contain carbon monoxide, which is colorless, odorless and poisonous. If you inhale exhaust emissions, you may suffer carbon monoxide poisoning.
- Do not keep the engine running for any length of time in a place that is poorly ventilated. It is particularly dangerous to run the engine in a garage or other indoor place that could easily fill with exhaust gases because you could suffer carbon monoxide poisoning.
- Inspect the exhaust pipe from time to time. If you notice any defect (for example, a damaged joint, or a hole or crack caused by corrosion), have checks and maintenance performed by the nearest Isuzu Dealer. Continuing to use the vehicle without having the defect repaired would be dangerous because exhaust gases could get into the cab and cause carbon monoxide poisoning.
- If exhaust gases get into the cab, completely open all of the windows and place the inside/outside air selector of the heater or air conditioner to outside air. Promptly have checks and maintenance performed by the nearest Isuzu Dealer. Continuing to use the vehicle without having the defect repaired would be dangerous because exhaust gases could get into the cab and cause carbon monoxide poisoning.

Starting the Engine

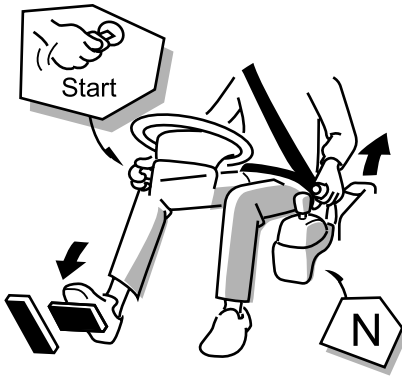
**CAUTION**

- Make sure that the parking brake lever is securely pulled. On a manual transmission model, make sure the gearshift lever is in the "N" position and then hold the clutch pedal down fully before starting the engine. On a AMT model, hold the brake pedal down firmly and make sure the gearshift indicator is showing "N" before starting the engine.
- Be sure to sit in the driver's seat to start the engine. If you are not sitting in the driver's seat (if, for example, you reach through the window or through the door opening), you cannot confirm the "N" position. If you start the engine of a manual transmission model with the shift lever in a position other than "N", the vehicle could move.

Starting the Engine → Refer to page 4-4

If the Vehicle Has not Been Used for a Long Period



ADVICE

- Before using a vehicle that has not been driven for a long period, check the engine, transmission and transfer case for oil leakage, and make sure the oil is at the required levels. If there is insufficient oil, it will not adequately reach and lubricate components, and a breakdown will result.
- Start the engine and allow it to idle for at least five minutes. Check for abnormal noises.
- For instructions on warming up the engine, refer to "Starting the Engine" on page 4-4.

Recommendations for Warming Up the Engine

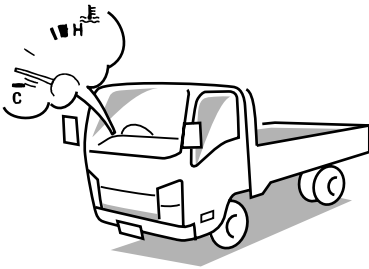

The engine is sufficiently warmed up when the needle of the engine coolant temperature gauge starts to move.



ADVICE

- Do not rev the engine or quickly accelerate before the engine has sufficiently warmed up (in other words, when the engine is cold). Oil would not have adequately reached and lubricated components, so a breakdown would result.
- The exhaust pipe becomes extremely hot while the engine is idling. Before warming up the engine, make sure there is no flammable material (for example, dry grass, waste paper, oil or old tyres) near the exhaust pipe.

Do not Run the Engine in a Garage**WARNING**

- Running the engine in a poorly ventilated place can lead to carbon monoxide poisoning. Choose a well ventilated place when starting and warming-up the engine. Also, do not perform manual diesel particulate defuser (DPD) regeneration indoors. Combustion of particulate matter (PM) during DPD regeneration produces white smoke.

DPD Manual Regeneration Procedure
→ Refer to page 4-156

Do not Forget to Release the Parking Brake**ADVICE**

- Pulling away with the parking brake still applied can damage the brake system.
- Before pulling away, make sure the parking brake is not set by checking that the parking brake warning light is not on.

Parking Brake Warning Light
→ Refer to page 4-51

Parking Brake Lever
→ Refer to page 4-77

Pulling Away in a Manual Transmission Model**ADVICE**

- Pull away gently in second gear or lower (first gear on a slope). Pulling away in a high gear, pulling away rapidly or slipping the clutch for a long time while pulling away would damage the clutch.

Appropriate Gearshifts

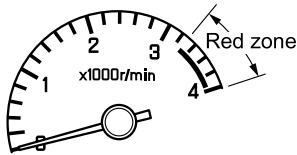
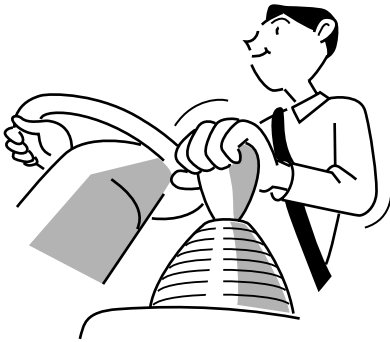

ADVICE

- Downshifts are performed for two main purposes:
 - For engine braking on a steep and/or long downward slope
 - For responsiveness and economy on an uphill slope

[Cautions for downshifts]

- Allowing the engine to overrun can result in engine damage. Do not allow the engine to overrun when downshifting.
- Driving uphill
Downshift early to avoid heavy engine load.
- Driving downhill
In principle, you should use the same gear(s) that you used to drive up the hill. Drive at a speed that does not cause the engine to overrun (exceed its r/min limit) and the tachometer needle to enter the red zone.

Drive at a speed that does not cause the tachometer needle to enter the red zone.

Tachometer → Refer to page 4-11

Gear Shift Lever → Refer to page 4-78



NOTE

[What is engine brake?]

- Engine brake is the braking effect that occurs when you release the accelerator pedal while driving. The lower the gear, the stronger the engine brake.

Never Stop the Engine While Driving

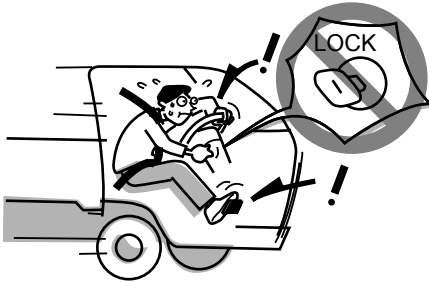

WARNING

- Do not move the starter switch away from the "ON" position while the vehicle is being driven. If the engine stops while the vehicle is moving, the brakes would not work properly, and the steering wheel and clutch pedal would become extremely stiff and hard to operate. The engine could also be damaged.
- Stopping the engine while driving would be extremely dangerous because the power steering would stop working, making the steering wheel extremely hard to turn.
- Stopping the engine while driving would be extremely dangerous because the warning lights, indicator lights and other electrical circuitry would completely stop working.
- Placing the starter switch in the "LOCK" position while driving would be extremely dangerous because the key could come out, causing the steering wheel to lock so that you could not turn it.

Starter Switch → Refer to page 4-60

Driving Down a Long Slope

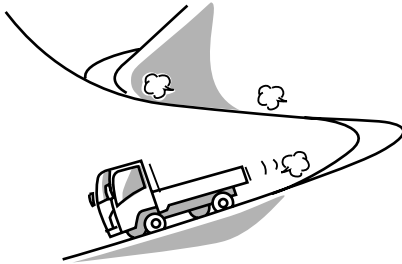

When driving down a long slope, use engine brake and the exhaust brake together with the foot brakes. Using the exhaust brake and low-gear engine brake reduces the work load on the foot brakes and yields greater braking force. Even so, use the foot brakes appropriately to prevent the engine over-revving.

Exhaust Brake Switch

→ Refer to page 4-69



CAUTION

- Frequent use of the foot brakes can cause vapor lock and brake fade, resulting in reduced brake effectiveness. Even so, you should be very careful when using engine braking in a low gear because the engine is likely to over-rev.
- Do not adjust the exhaust brake valve.



NOTE

[What is engine brake?]

- Engine brake is the braking effect that occurs when you release the accelerator pedal while driving. The lower the gear, the stronger the engine brake.

[What is the exhaust brake?]

- The exhaust brake is a system that closes the exhaust pipe and uses the force of the exhaust emissions to enhance the effectiveness of engine brake.

[What is vapor lock?]

- If the brakes overheat due to frequent use, the heat can cause the brake fluid to boil so that air bubbles are created in the brake fluid. Pressing the brake pedal simply compresses the air bubbles; pressure is not transmitted to the wheel cylinders, so the brakes' effectiveness sharply deteriorates. This phenomenon is called vapor lock.

[What is brake fade?]

- Frequent use of the brakes can cause the brakes to overheat so that the frictional force of the brake linings decreases and the brakes become less effective than normal. This phenomenon is called brake fade.

[What is an engine overrun?]

- An engine overrun is an engine-speed increase that causes the tachometer needle to enter the red zone.

Driving in Bad Weather (Rain, Icy Roads, Snowy Roads, etc.)



CAUTION

- In bad weather, visibility is reduced and slippery road surfaces increase stopping distances. Drive more slowly than you would in good weather. Also, avoid sharp turns of the steering wheel and hard braking. Use engine brakes together with the foot brakes to decelerate. Using the exhaust brake on a slippery road surface could cause the tyres to slip.



ADVICE

- There is a risk of hydroplaning, particularly where water tends to collect on the road surface. Drive at speeds that allow you to stay in complete control.
- If you cannot avoid driving on a flooded road, first check the depth of the water and then drive through the water at a slow, constant speed. There is a risk that water will get into the engine's cylinders and cause engine damage (water hammering). Keep your speed down, and drive with great care.



NOTE

[What is hydroplaning?]

- If a vehicle is driven at high speed on a road that is covered with water, a layer of water can form between the tyres and road surface, causing the tyres to lose their grip and slide across the water. This phenomenon is called hydroplaning. It is dangerous because it makes the steering wheel and brakes useless.

Brake Effectiveness when the Vehicle Has Been Driven on a Flooded Road or Washed

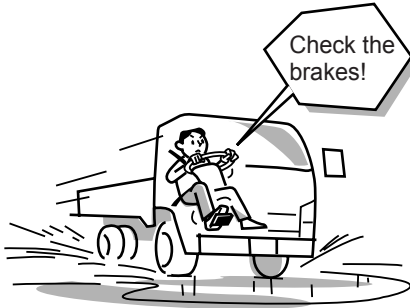

CAUTION

- When the vehicle is driven on a flooded road, parked on a flooded road or washed, water can get into the brakes and reduce their effectiveness. If the brakes do not work well afterward, drive slowly and gently press the brake pedal several times until the brakes dry out and start working normally. Before parking the vehicle in winter, press the brake pedal several times in the same way to get rid of moisture in the brakes. Otherwise, the moisture in the brakes may freeze and make the vehicle immovable. In addition, promptly have the nearest Isuzu Dealer perform water-ingress checks and, where necessary, lubricate brake, engine, electrical, transmission, differential and transfer case components.

Sidewinds



ADVICE

If the vehicle catches a sidewind and drifts sideways, firmly grip the steering wheel, decelerate to a speed that allows you to stay completely in control and make a directional correction. The vehicle may catch strong sidewinds in the following situations:

- emerging from a tunnel; driving over a bridge, driving on an embankment or driving through a cutting
- being overtaken by a large truck or bus
- overtaking a large truck or bus

Dealing with a Blowout or Flat Tyre while Driving

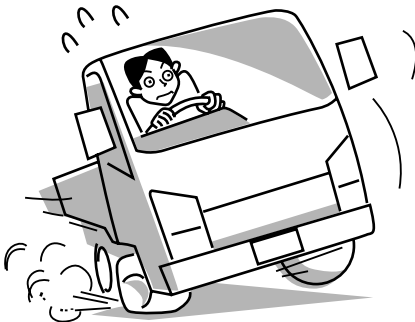

WARNING

- If you feel any abnormality in a tyre while driving, immediately stop in a safe place. If you continue to drive on a flat tyre, undue force would be applied to the wheel studs, possibly causing the bolts to break and the wheel to come off.



ADVICE

- If a blowout or flat tyre occurs while you are driving, calmly grip the steering wheel and gradually apply the brakes to decelerate. (Hard braking would be dangerous because it could cause the steering wheel to be pulled to one side.) Stop the vehicle in a safe place, and change the tyre.

Spare Tyre → Refer to page 7-98

Handling the Jack → Refer to page 7-128

Changing Tyres → Refer to page 7-88

If the Underside of the Vehicle Receives a Hard Bump



ADVICE

- If the underside of the vehicle receives a hard bump, stop in a safe place where the vehicle will not obstruct traffic and check for brake fluid leakage, fuel leakage and component damage. If any part of the vehicle is damaged or broken, promptly have the vehicle inspected and repaired by the nearest Isuzu Dealer.

If a Warning Light or Indicator Light Comes On or Flashes

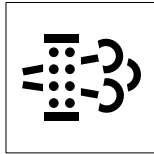
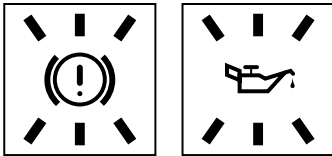

ADVICE

- If a warning light comes on or flashes, do not ignore it and keep driving. Be sure to take corrective action referring to the explanation of the meters, warning lights and indicator lights.

How to Read the Instruments (Instrument Layout)

→ Refer to page 4-8

Warning and Indicator Lights Layout

→ Refer to page 4-15

AMT Model SA

On a AMT model, the driver does not use a clutch pedal when pulling away, changing gears or stopping; he/she uses only the gearshift lever, accelerator pedal, and brake pedal. In addition, a AMT model allows the driver to drive the vehicle with the gears changed automatically. Be sure to learn the characteristics of the AMT model and how to correctly operate it. When the vehicle is stationary, remember to keep the brake pedal firmly pressed and, if necessary, place the gearshift lever in the "N" position and apply the parking brake.

Immediately after engine startup, while the air conditioner is running, and during diesel particulate defuser (DPD) regeneration, the engine speed rises, making creep stronger than it is at other times. When you move the gearshift lever out of the "N" position, firmly press the brake pedal.

Model with AMT SA

→ Refer to page 4-81

**NOTE**

[Creep]

- With the engine running and a gear position other than "N" selected, power reaches the wheels even when the accelerator pedal is not pressed, causing the vehicle to tend to move. This phenomenon is called creep. The higher the engine speed, the stronger the creep and the greater the vehicle's tendency to move.

Operate the Brakes with Your Right Foot



ADVICE

- Sit in the correct driving position, and use your right foot to operate the brake and accelerator pedals. To avoid accidentally pressing the wrong pedal, check the pedal positions and practice putting your foot on the desired pedal.
- To ensure reliable brake application, be sure to use your right foot to press the brake pedal.

Pulling Away

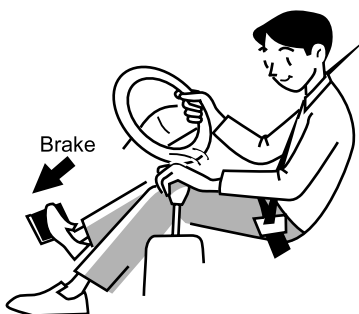

1. Sitting in the correct driving position, firmly hold down the brake pedal with your right foot and place the gearshift lever in the "D", "R", or "M" position.
2. Check to be sure the area around the vehicle is clear and check the gearshift lever position and shift indicator, then release the parking brake lever.
3. Take your foot off the brake pedal, then gradually press the accelerator pedal to pull away.



WARNING

- When you move the gearshift lever to a position other than "N", creep will cause the vehicle to move. When pulling away, be sure to keep the brake pedal pressed as you operate the gearshift lever.
- Do not operate the gearshift lever while pressing the accelerator pedal. Doing so is dangerous because the vehicle would suddenly move.
- Immediately after engine startup, while the air conditioner is running, and during diesel particulate defuser (DPD) regeneration, the engine speed automatically rises, making creep stronger than it is at other times. Keep the brake pedal firmly pressed.



ADVICE

[Essential points for safety]

- Even if you plan to move only a short distance, adopt the correct driving position and make sure you can firmly press the brake and accelerator pedals.
- When you reverse, you twist to look rearward so pedal operation becomes difficult. Firmly press the brake pedal while twisting your body. Also, get in the habit of immediately returning the gearshift lever to the "N" position after reversing. When pulling away, visually check the gearshift lever position and the shift indicator.
- When repeatedly shifting between forward and reverse gears for a multiple-point turn or a K-turn, firmly press the brake pedal and confirm that the vehicle is completely stopped before shifting.
- On a AMT model, you cannot move the gearshift lever out of the "N" position unless you are pressing the brake pedal. If you are unable to move the gearshift lever, release the brake pedal, then press again and try moving the gearshift lever.
- On a AMT model, standing starts are typically performed in second gear. If you need extra-strong traction for pulling away (for example, when the vehicle is loaded), you can select a standing start in first gear by holding down the brake pedal and then placing the 1st start switch in the "ON" position or placing the gearshift lever in the "M" position and moving it in the "-" (downshift) direction. (The method using the gearshift lever yields a gear shift in manual mode.)

Model with AMT SA

→ Refer to page 4-81

Actions that Can Lead to a Breakdown with a AMT Vehicle

Action that can lead to a breakdown	Breakdown symptom
<ul style="list-style-type: none"> • Stopping the vehicle on an uphill road with the gearshift lever in a position other than "N", the accelerator pedal pressed, and the brakes not applied • Pressing the accelerator pedal and brake pedal at the same time • Continuously driving in an inappropriate gear • Repeatedly performing abrupt standing starts and stops 	<ul style="list-style-type: none"> • The AMT clutch oil overheats.
<ul style="list-style-type: none"> • Operating the gearshift lever with the accelerator pedal pressed and the engine speed high 	<ul style="list-style-type: none"> • The transmission gears or clutch are overloaded.
<ul style="list-style-type: none"> • Placing the starter switch in the "ACC" or "LOCK" position while driving • Keeping the gearshift lever in the "N" position on a long downward slope (this is dangerous due to the lack of engine brake) 	<ul style="list-style-type: none"> • The transmission is not properly lubricated.

Four Wheel Drive (4WD) Model

Four-wheel drive does not make it possible to drive a vehicle absolutely everywhere. Exercise caution when using the accelerator pedal, steering wheel and brake pedal. Concentrate on driving safely, paying attention to the condition and slope angle of the road surface.

Four Wheel Drive (4WD) Model

→ Refer to page 4-124

Driving on Snow-covered or Icy Roads



On a snow-covered or icy road, drive at a constant speed and keep your speed low enough to stay completely in control.

When applying the brakes, lightly push the pedal several times rather than giving it one hard push. A single hard push of the pedal would be dangerous because it could cause the vehicle to slip, making the steering wheel useless.



ADVICE

- Use tyre chains and winter tyres on snow-covered or icy roads.

Winter Tyres → Refer to page 6-20

Using Tyre Chains → Refer to page 6-22

Driving in Sand or Mud

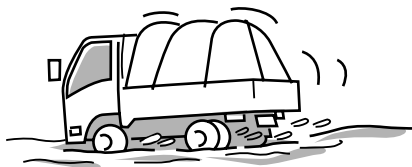

When driving in sand or mud, go as slowly as possible, avoiding hard braking, sudden acceleration and sharp turns of the steering wheel.

It is difficult to ascertain the condition of the road surface when you are driving on sand or mud, so there is a risk of getting stuck. When necessary, get out of the vehicle and check the condition of the road surface.



NOTE

- When you cannot avoid driving through deep mud, using tyre chains is an effective way to avoid getting stuck.

Driving through Water

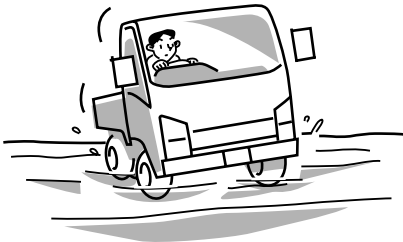

The vehicle is not completely impervious to water. Avoid driving through water. After driving through water, check the effectiveness of the brakes.

Also, promptly have the nearest Isuzu dealer perform water-ingress checks and, where necessary, greasing on the engine, electrical components, transmission, propeller shaft, differential and transfer case.

Guidelines for Switching between 2WD (Rear-Wheel Drive) and 4WD (Four-Wheel Drive)

Drive type	2WD	4WD
4WD switch		
4WD indicator light	OFF	ON
Driving conditions	During normal driving on an ordinary road or highway	Snow-covered roads, icy roads, steep slopes, and other roads where progress is too difficult with 2WD.

Transfer Gear Control Switch V

Either the 4H or 4L gear can be selected with this switch when operating in 4WD mode. Select either gear appropriately depending on driving conditions.

Gear Switching Method

Use the transfer gear control switch to switch the gear from 2H-4H to 4L and vice versa. Be sure to stop the vehicle and press the clutch pedal when you make such a selection.

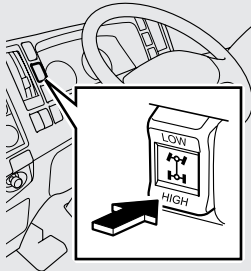
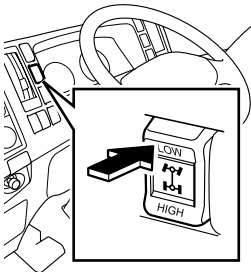
	Switch position	Usage conditions
2H-4H (for high-speed driving)		Use this position for normal driving in 2WD mode. If two-wheel driving becomes difficult on snow-covered, icy, soft, or sandy surfaces, move the 4WD switch to the 4WD position while keeping the transfer gear control switch at "HIGH".
4L (for low-speed driving)		Select the "LOW" side of the transfer gear control switch when moving off or driving in 4WD mode on steep, uphill inclines, soft surfaces, or other situations where a particularly large torque is required.



ADVICE

- This vehicle is designed to prevent the LOW gear from being selected even when the LOW side of the transfer gear control switch is pressed while driving in 2WD mode. Before you can switch from 4H to 4L, the 4WD switch must be set to the 4WD position.
- Switching the gear from 4WD to 2WD using the 4WD switch is possible only when the HIGH side of the transfer gear control switch is selected. Before you can switch the mode to 2WD, the vehicle must be stopped and the transfer gear control switch must be in the HIGH position.

Stopping and Parking

Parking



ADVICE

- Choose a flat place where stopping and parking are permitted and where the vehicle will not obstruct traffic. Firmly apply the parking brake and make sure the vehicle does not move.
- Avoid parking for long periods with cargo on the vehicle.
- Remove all dirt from the vehicle's light lenses and reflectors to ensure that the vehicle can be seen from other vehicles.

Applying the Parking Brake



ADVICE

- Except in an emergency, do not apply the parking brake until the vehicle has come to a complete stop. Applying the parking brake before the vehicle has stopped can cause a breakdown.

Parking Brake Lever → Refer to page 4-77

Parking Safely on a Slope

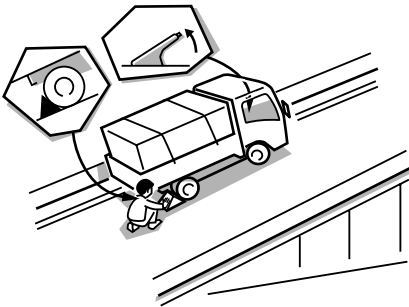

CAUTION

- Avoid parking your vehicle on a slope as much as possible and choose a level and flat place. If it is unavoidable to park your vehicle on a slope, be sure to set the parking brake fully, make sure that the vehicle does not move, and block the wheels with chocks for added safety. Also, leave the vehicle in gear to further ensure that it will not move.
- Leave the steering wheel turned such that the vehicle will be stopped by an obstruction (for example, the curb) in the unlikely event that it moves.

Parking in Gear → Refer to page 4-87

Do not Use the Hill-Start-Aid (HSA) for Parking

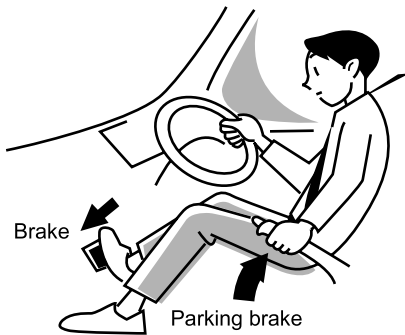

CAUTION

- HSA is a device to stop the vehicle temporarily and cannot replace the parking brake. When parking, be sure to firmly apply the parking brake.

Hill-Start-Aid (HSA)

→ Refer to page 4-98

Napping in the Vehicle



WARNING

Before taking a nap in the vehicle, be sure to stop the engine and place the starter switch in the "LOCK" position. Otherwise, any unintended contact with the gearshift lever or accelerator pedal while you are asleep could cause the vehicle to move, resulting in an accident.

- If you leave the engine running and unintentionally keep the accelerator pedal pressed while asleep, the engine and exhaust pipe could become abnormally hot, resulting in a fire.
- If you leave the engine running while taking a nap with the vehicle parked in a place where exhaust gases could get into the cab (for example, a place that is poorly ventilated), you could suffer carbon monoxide poisoning.

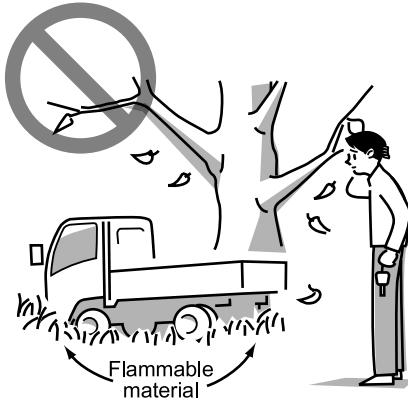
Keep Flammable Material Away from the Vehicle**CAUTION**

- The exhaust pipe is extremely hot immediately after vehicle operation. Before parking, make sure the area is free of flammable material (for example, dry grass, waste paper, oil or old tyres). Take particular care when parking in a garage.
- Use caution concerning exhaust gases while the engine is idling. Be particularly careful when the power take-off (PTO) is operating (if your vehicle is equipped with a PTO) or the diesel particulate defuser (DPD) is regenerating while the engine is idling.

DPD Manual Regeneration Procedure

→ Refer to page 4-156

Stopping and Parking with the Engine Running**WARNING**

- When stopping and parking with the engine running: If your vehicle is equipped with a manual transmission, be sure to place the gearshift lever in the "N" position to select neutral. With a AMT vehicle, make sure the shift indicator is showing "N". Then, firmly apply the parking brake. Unless you take these steps, any unintended pressure on the accelerator pedal could cause an accident.

CAUTION

- The diesel particulate defuser (DPD) may automatically start regeneration when the vehicle is stopped and parked with the engine running. To prevent a fire, make sure there is no flammable material near the muffler, DPD, and exhaust pipe. Be careful not to get burned by hot exhaust gases.

Do not Touch the Gearshift Lever while the Vehicle is Stationary with the Engine Idling

WARNING

- Do not touch the gearshift lever while the vehicle is stationary with the engine idling. If you touch the gearshift lever at this time, a gear could be selected and the vehicle could move even with the parking brake applied. The risk of knocking against the gearshift lever and causing an accident is particularly great when you move in or out of your seat.

Be Sure to Have the Engine Running when the Vehicle is Moving

CAUTION

- When the engine is not running, the power steering system does not work so the steering wheel is hard to turn. Also, the brake booster does not work so there is little braking ability. If you coast down a slope without the engine running, you would not be able to properly control the vehicle and could have an accident.

Look Around before Opening a Door

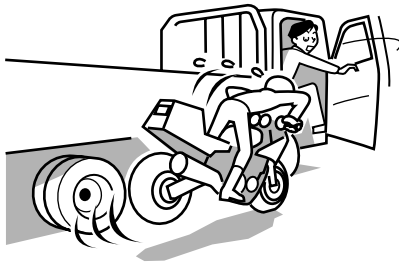

CAUTION

- Before opening a door, check the area around the vehicle by looking forward, rearward and to the sides. If you suddenly open a door without checking the surrounding area, the door could be hit by a vehicle behind you or a pedestrian.

Leaving the Vehicle

WARNING

- When leaving the vehicle, be sure to apply the parking brake, stop the engine and lock the doors. Do not leave valuables where they can be seen from outside the vehicle.
- If you are traveling with a child, do not leave the child alone in the vehicle. If the child touches the controls or equipment, an accident could occur. (For example, the vehicle could move or a fire could start.) Also, the cab inside could become dangerously hot in hot weather.
- Do not leave eyeglasses or a lighter in the vehicle. If the cab inside becomes hot, a lighter left there could explode and plastic eyeglass lenses or frames could deform or crack.

Metallic Plinking Sound from the Muffler

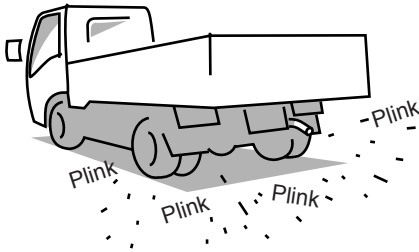

NOTE

- Immediately after stopping the engine, you may hear a metallic plinking sound from the muffler. This sound occurs as the muffler cools down and contracts. It does not indicate an abnormality or breakdown.

Starting to Drive When the Vehicle Has Been Parked

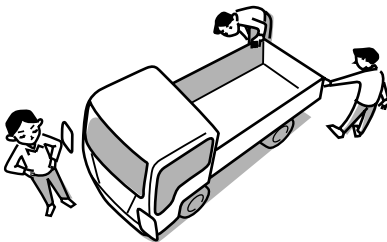

Before pulling away, perform a thorough safety check, making sure there are no children or obstructions around the vehicle.

Reversing

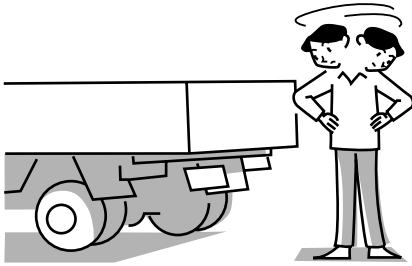

If you cannot see the area behind your vehicle well enough to confirm it is safe to back up, get out of the vehicle and check behind it.

Pulling Away after a Temporary Stop

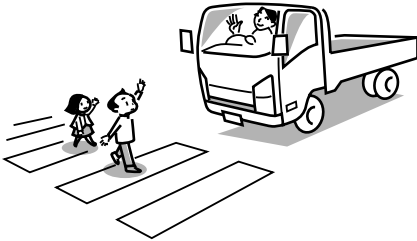

CAUTION

- Make it a habit to look around and confirm that it is safe to pull away after a temporary stop (at traffic lights, for example).

Staying Safe

When the Engine Coolant is Hot

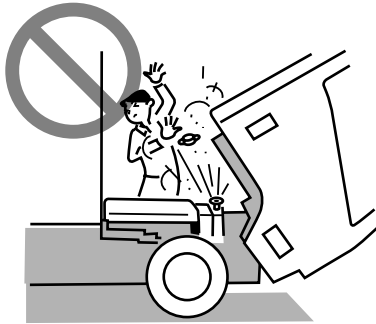

WARNING

- Do not loosen or remove the radiator cap while the engine coolant is hot. Doing so would be dangerous because steam and hot air would shoot out.

When the Engine Overheats

→ Refer to page 8-22

When the Silencer and Exhaust Pipe are Hot

CAUTION

- When the engine is running and immediately after vehicle operation, the diesel particulate defuser (DPD), silencer, and exhaust pipe are extremely hot. Be careful not to inadvertently touch them when working near them (for example, tilting the cab or operating an attachment). Otherwise, you could get burned.

After Using the Ashtray



WARNING

- Be sure to close the ashtray after using it. Otherwise, any unextinguished cigarette butt could set fire to other cigarette butts, resulting in a fire.
- Do not allow the ashtray to become overly full of cigarette butts. Also, do not put flammable material in the ashtray.

Ashtray → Refer to page 5-23

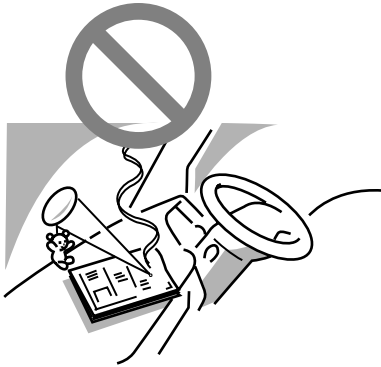
Do not Attach Accessories to the Windshield or Windows**WARNING**

- Do not attach ornaments, films or other accessories to the windshield or windows. They would impair visibility. Also, any plastic suction cups used to attach accessories could cause a fire or other accident by acting as lenses.

Do not Use a Mobile Telephone while Driving**CAUTION**

- Drivers should never use mobile telephones or car phones in any mode other than Hands Free while driving. Doing so is dangerous.
- Using a mobile telephone while driving could result in an accident because you would not be paying full attention to your surroundings.
- If you are driving and you wish to use a mobile telephone, first stop the vehicle in a safe place.

Using the Jack

WARNING

- Jacking up a vehicle on slope or soft ground is extremely dangerous. Be sure to jack up the vehicle on a firm, level surface.
- Set the jack in the correct position. Do not forget to first apply the parking brake and place chocks around the wheels.
- When a rear wheel is jacked up, the parking brake has no effect. Failing to first put chocks in the correct places would be dangerous because the vehicle could move.
- On a limited slip differential (LSD) model, any transmission of torque to the rear wheels can make the vehicle move even if one rear wheel is off the ground. If any rear wheel is on the ground, do not apply torque to the rear wheels.
- Do not look under the vehicle or get under the vehicle while the vehicle is jacked up. Doing so would be dangerous.

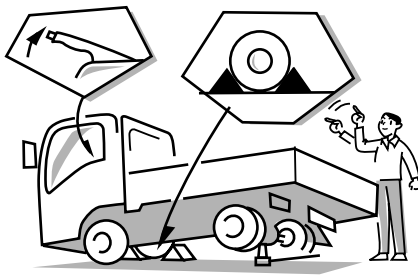

Tools → Refer to page 7-7
Handling the Jack → Refer to page 7-128

If the Battery Goes Flat

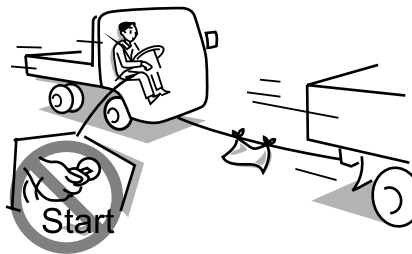

CAUTION

- Do not try to start the engine by pushing or towing the vehicle. You could damage the engine.

When the Battery Goes Flat

→ Refer to page 8-12

Preventing Breakdowns

Do not Rest Your Foot on the Clutch Pedal while Driving M/T



ADVICE

- If you rest your foot on the clutch pedal while driving, the clutch could partially disengage without you realizing it, causing the clutch plates to wear and the clutch to slip. Also, do not slip the clutch as a way to hold the vehicle in position (instead of using the brakes) on, for example, an uphill road.

Is the Engine Oil Dirty?

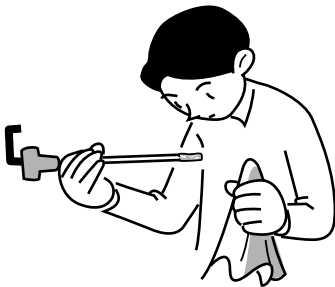

ADVICE

- The engine oil performs the following important functions:
 - It prevents engine parts from becoming worn.
 - It cools engine parts.
 - It cleans engine parts.
 - It seals the combustion chambers and prevents rust.
 Replace the engine oil at regular intervals.

Daily Checks (Preoperational Checks)

→ Refer to page 7-18

Engine Oil → Refer to page 7-24

Maintenance Schedule

→ Refer to page 7-159

Do not Climb onto the Engine



ADVICE

- Do not step on the engine or climb onto it. You could cause an engine failure by, for example, damaging the cylinder head cover or various connectors.

Do not Leave the Steering Wheel Fully Turned for a Long Time

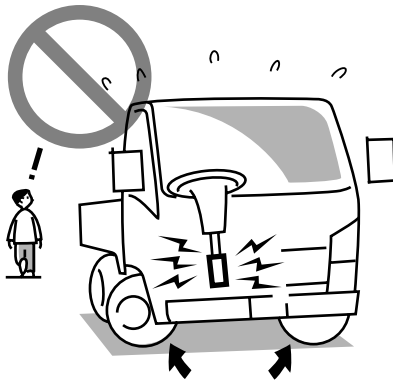

WARNING

- If you leave the steering wheel fully turned for a long time, the oil in the power steering oil pump would become extremely hot. This would cause poor lubrication, oil tank damage and seal deterioration, leading to power steering oil pump damage, power steering unit damage and power steering hose damage. As a result the steering wheel could become extremely hard to turn and a fire or other accident could occur.

Make Sure the Vehicle is Inspected at Regular Intervals

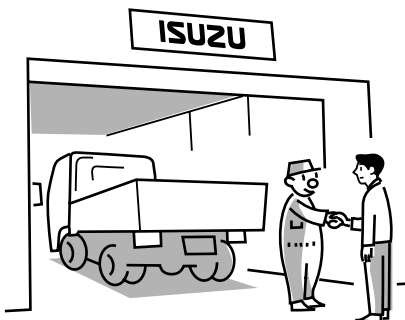

ADVICE

- Inspections and maintenance enable you to use the vehicle with peace of mind. They also extend the vehicle's service life.

Daily Checks (Preoperational Checks)

→ Refer to page 7-18

Engine Oil

→ Refer to page 7-24

Maintenance Schedule

→ Refer to page 7-159

In a Vehicle Equipped with a Hydraulic Brake Booster (HBB), Do Not Keep the Brake Pedal Depressed for an Extended Period

WARNING

- Failure to follow the above instruction will cause the oil inside the HBB oil pump to get very hot. This could damage the HBB tank and deteriorate seals and also could cause damage to the HBB oil pump, HBB unit and/or HBB hosing. Eventual leakage of HBB oil, sudden increase in brake pedal resistance and fire could unexpectedly result in an accident.

When to Visit Your Isuzu Dealer

Do not Modify the Vehicle

CAUTION

- Attaching parts that are not suitable for the vehicle's performance and functions could lead to a breakdown or accident. For adjustments (for example, engine adjustments) and equipment installation, consult your Isuzu Dealer.
- If you wish to attach accessories to the vehicle, consult your Isuzu Dealer.

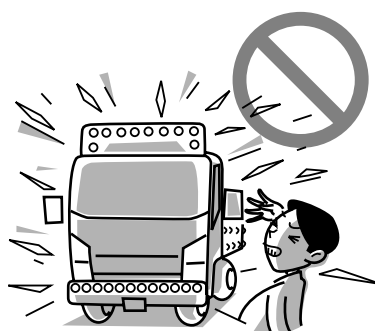

Have Engine Adjustments Made by Your Isuzu Dealer



CAUTION

- Do not make engine adjustments yourself. Be sure to consult your Isuzu Dealer.

Electric Welding



ADVICE

- Careless electric welding of vehicle parts can cause welding current to flow back through the vehicle's ground circuit and damage electrical and electronic parts so that they do not function normally. Whenever electric welding is necessary, consult your Isuzu Dealer.

Replacing Tyres and Wheels

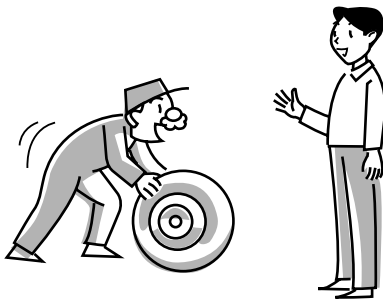

CAUTION

- Consult your Isuzu Dealer before replacing tyres or wheels. Never use wheels that are not designed for the vehicle, tyres of different types at the same time or tyres that are not the specified size. Doing so would impede safe vehicle operation.

Wheels and Tyres → Refer to page 7-77

Changing Tyres → Refer to page 7-89

Installing Electrical Equipment

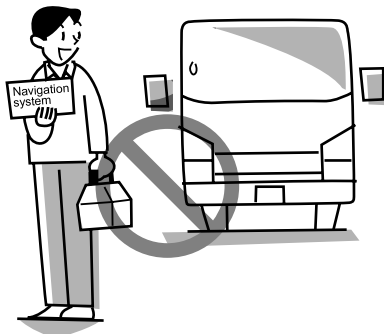

CAUTION

- Inappropriate installation or removal of audio, radio or other electrical equipment can adversely affect other electrical equipment and cause a breakdown or fire. It can also cause unexpected, dangerous airbag deployment. Be sure to have electrical equipment installed or removed by your Isuzu Dealer.



ADVICE

[Installation of radio equipment]

- Do not install any unauthorized radio set, or any radio set or antenna that does not comply with relevant standards. Noise from the radio set could cause electromagnetic interference with the vehicle's electronic equipment and other systems, resulting in a vehicle breakdown or in a malfunction of electronic equipment. Consult your Isuzu Dealer if you wish to install radio equipment.

Diesel Particulate Defuser (DPD)

DPD reduces particulate matter (PM) in the exhaust emissions. The DPD filter captures PM. When a certain amount of PM has accumulated in the DPD filter, the filter is automatically regenerated. (The PM is burned away.) To prevent a DPD failure, be sure to observe the following points:

WARNING

- The DPD and exhaust pipe are extremely hot while the engine is running, during DPD filter regeneration (PM combustion) and immediately after vehicle operation. Be careful not to inadvertently touch them. Otherwise, you could be burned.
- Any dry grass, paper waste or other flammable material near the vehicle could catch fire.
- Before doing maintenance work on the vehicle, shut down the engine and allow it to cool down. Otherwise, you could be burned.

ADVICE

- Use Isuzu genuine engine oil compatible with the DPD. Using oil other than Isuzu genuine engine oil compatible with the DPD would shorten the time between DPD filter cleaning and could increase fuel consumption.
- Be sure to use extra-low-sulfur diesel fuel (with sulfur content no higher than 10 ppm) or low-sulfur diesel fuel (with sulfur content no higher than 50 ppm).
- If you fill the vehicle with poor-quality fuel, water-removing additive or other additive, gasoline, kerosene or alcohol-based fuel, it could harm the fuel filter, prevent proper movement of fuel-lubricated parts in the injectors and adversely affect engine components, possibly resulting in a breakdown.
- Do not modify the DPD or exhaust pipe.
Changing the alignment, length or diameter of the exhaust pipe would adversely affect the exhaust system's exhaust emission reduction function. If any modification is necessary to install a component to the rear of the vehicle, consult your Isuzu Dealer.
- Although the DPD filter automatically undergoes regeneration (burning of the accumulated PM) when a certain amount of PM has accumulated, driving conditions can prevent completion of regeneration. In a model without a multi-information display (MID), the DPD manual regeneration indicator light will flash at this time. In a model with a MID, the "PUSH DPD SWITCH" indicator (amber) will flash. Perform manual regeneration in accordance with the proper procedure.
This is to restore DPD function and is normal.

**NOTE**

- If the vehicle is stationary with the engine idling during DPD regeneration, the exhaust brake or exhaust throttle operates. Operating sounds will be heard when the exhaust brake or exhaust throttle is activated or deactivated. The sounds do not indicate a fault.
- Combustion of PM during DPD regeneration can cause white smoke to be briefly emitted from the exhaust pipe. The white smoke does not indicate a fault. Do not perform manual regeneration in any poorly ventilated indoor place.
- When a new vehicle has been driven a certain distance, it can emit white smoke during DPD regeneration. The white smoke does not indicate a fault. The vehicle may not emit white smoke during its initial operation when new.
- Owing to the exhaust emission reduction function, the exhaust gases emitted by the exhaust pipe smell different from those emitted by the exhaust pipes of earlier diesel vehicles.
- The exhaust brake may automatically be activated in order to prevent emission of white smoke if the engine idles continuously over an extended period of time.

Diesel Particulate Defuser (DPD)

→ Refer to page 4-154

Engine Oil

→ Refer to page 7-24

Inspection and Maintenance

Performing regular inspections and maintenance prevents damage. Be sure to perform inspections and maintenance at regular intervals. Also, quickly rectify any fault in the vehicle (even a small fault) to prevent it from becoming more serious.

If a symptom shown in the following table occurs, perform inspections and take corrective action in accordance with the table.

If you are unable to perform a repair, the corrective action shown in the table does not eliminate a symptom or you can't locate a fault, contact the nearest Isuzu Dealer.

Symptom	Cause	Corrective action	Reference page
White exhaust smoke	Engine not sufficiently warming up	Allow the engine to warm up.	4-63
	Too much engine oil	Correct the oil level.	7-24
	Engine control system faulty	⊙	—
	Fuel system faulty	⊙	—
	Continuous idling for a long period (more than two hours)	With the vehicle stationary in a place where it will not obstruct traffic, hold down the accelerator pedal and check that white smoke is not emitted.	—
Black exhaust smoke	Engine control system faulty	⊙	—
	The air cleaner clogged	Clean or replace the element.	7-50 7-52
	Fuel system faulty	⊙	—
	Exhaust system clogged	⊙	—
	DPD faulty	⊙	—



ADVICE

Any item for which there is a ⊙ in the "Corrective action" column requires repairs and adjustments. Contact the nearest Isuzu Dealer.

Model with Speed Limit Device **Characteristics of the Speed Limit Device**

The speed limit device restricts excessive speed to prevent a serious accident.

**CAUTION**

- The speed limit device does not control braking, so it is possible for the vehicle to exceed the set speed on downhill slopes.
- If the tyre size is changed, the speed limit device may not work normally. Have adjustments made by your Isuzu Dealer.

**NOTE**

- The speed limit device restricts the vehicle's speed by controlling the fuel injection volume. It prevents the speed from exceeding 90 km/h (56 MPH) regardless of the pressure on the accelerator pedal.

Seat Belt with Pretensioner and SRS Airbag System v



If a vehicle that has a seat belt with pretensioner and supplemental restraint system (SRS) airbag system suffers a frontal impact above a certain level, the seat belt with pretensioner and airbag (assuming the vehicle has a passenger airbag in addition to a driver airbag) securely restrain the driver and passenger in their seats and lessen the physical shock to their heads. To prevent the seat belt with pretensioner and airbag themselves from causing life-threatening injuries, be sure to observe the following points:

WARNING

- Before driving, adjust the seat to give you a correct driving position and fasten your seat belt. Do not sit closer than necessary to the steering wheel, and do not lean back further than necessary. If the vehicle has a passenger airbag, the passenger must not put his/her hands or feet on the instrument panel or sit with his/her face or chest close to the instrument panel. When the driver's airbag (and the passenger's airbag, if equipped) deploys, the driver and passenger can suffer burns and other serious injuries on the arms and face.
- No person riding in the vehicle should hold any object on his/her lap or otherwise place any object between him/herself and the airbag. In the event of airbag deployment, the object would represent a hazard because it could be propelled toward the person's face and/or prevent normal airbag operation.
- If you carry a child in the vehicle, be sure to observe the following points. Otherwise, the force of airbag deployment could give the child life-threatening injuries.
 - Do not drive the vehicle while letting the child stand in front of the passenger seat airbag or while holding him/her on your lap. The child would be in danger in either of these positions because he/she would be exposed to a powerful physical shock in the event of airbag deployment.
 - Do not use a passenger seat that has a passenger airbag to carry a child who needs a baby seat, child seat, junior seat or other seat designed specifically for children.
- If the vehicle has a passenger airbag, do not fit a baby seat, child seat or junior seat facing rearward. If the baby seat, child seat or junior seat were facing rearward, the shock created by deployment of the passenger airbag could inflict life-threatening injuries on the child.

Seats → Refer to page 3-19
Seat Belts → Refer to page 3-26

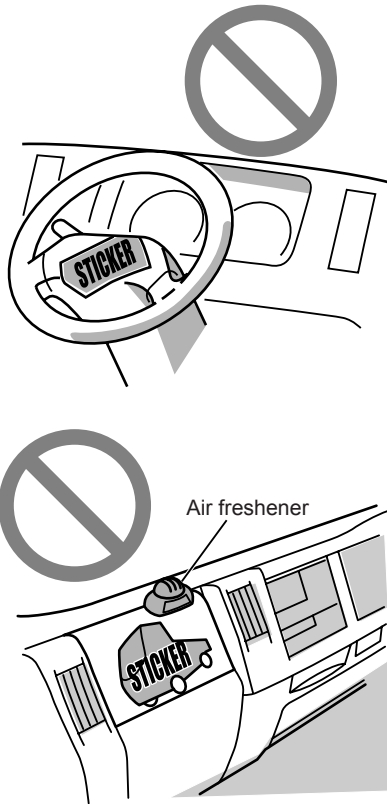

WARNING

- Any improper modification of the vehicle or attachment of accessories could prevent the seat belt with pretensioner or airbag from operating normally.
- Replacing the steering wheel with a steering wheel other than an Isuzu-specified one or affixing a sticker to the steering wheel pad would be dangerous because it could result in defective operation and cause the sticker to be propelled toward you in the event of airbag deployment. Also, do not affix any sticker to the top surface of the instrument panel or place any accessory or air freshener there. Such items could prevent the passenger airbag from functioning normally, and they could be propelled toward a passenger in the event of airbag deployment.

Warning (Continued)

Warning (Continued)

- The actions listed below require special measures. Please consult your Isuzu Dealer. Unless the correct measures are taken, the seat belt with pretensioner or airbag could be activated unexpectedly such that the seat belt rewinds or the airbag deploys, causing injuries. Also, the systems could be adversely affected such that they fail to operate.
 - Any repair or replacement in the vicinity of the steering wheel, instrument panel, centre console clutch pedal, or brake pedal
 - Repair, replacement or disposal of the seat belt with pretensioner and airbag, or scrapping of a vehicle that has a seat belt with pretensioner and airbag
 - Installation of audio equipment or accessories, or installation of body parts
 - Repairing or painting of panels at the front of the vehicle or panels on the cab

EDR Function

The vehicle has a computer that controls the SRS airbag system.

The computer constantly checks whether the SRS airbag system is working normally, and it has an event data recorder (EDR) function that records data about vehicle operation in the event that the vehicle suffers an impact or comes close to suffering an impact.

EDR Records

In the event that the vehicle suffers an impact or comes close to suffering an impact, the EDR records the following data:

- whether or not the driver's seat belt is fastened
- data related to SRS airbag system operation
- SRS airbag system fault diagnosis data



NOTE

- The EDR differs from typical data recorders in that it does not record video or the sound of conversations.

Recorded Data

Isuzu and its agents can obtain data recorded by the EDR and use them for the purpose of improving vehicle collision safety.

Neither Isuzu nor its agents will show or provide the data to any third party except in the following situations:

- The user of the vehicle gives consent.
- The data must be provided or shown to a third party in accordance with a court order or other demand that has legal force.

Vehicle Data Collection

Your vehicle, like other modern motor vehicles, has a number of sophisticated computer systems that monitor and control several aspects of the vehicle's performance. Your vehicle uses on-board vehicle computers to monitor emission control components to optimize fuel economy, to monitor conditions for airbag deployment and, if so equipped, to provide anti-lock braking and to help the driver control the vehicle in difficult driving situations. Some information may be stored during regular operations to facilitate repair of detected malfunctions.

Isuzu may download and retrieve stored information for the purpose of diagnosing, servicing, or repairing your motor vehicle or improvement to future Isuzu motor vehicles.



DOORS, WINDOWS AND SEATS

3

• Key	3-2
• Key with Immobilizer Transponder Chip <input type="checkbox"/>	3-3
• Keyless Entry System <input type="checkbox"/>	3-4
• Opening and Closing Doors	3-7
• Power Windows <input type="checkbox"/>	3-11
• Fuel Tank Filler Cap	3-13
• Tool Box <input type="checkbox"/>	3-16
• Seats	3-17
• Fully Adjustable Steering	3-21
• Mirrors	3-22
• Seat Belts	3-23

Key

Key with immobilizer transponder chip

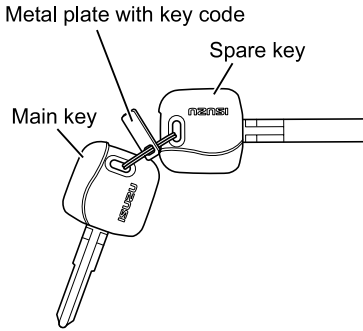

Key without immobilizer transponder chip

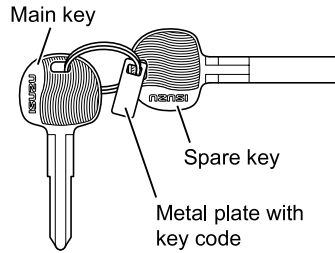

Both sides of the key are identical, so you can insert the key in the starter switch without worrying about which way you insert it.

The key code is indicated on a separate metal plate in order to prevent it from being acquired by an unauthorized person.

Where Is the Key Used?

Where	For what
Starter switch	Starting and stopping the engine
Front doors	Locking and unlocking the doors
Fuel tank filler cap (with key lock)	Locking and unlocking the filler cap



NOTE

- To prevent theft, store the metal plate with key code in a safe place other than the vehicle.
- Should you lose the key, please give the key number to the nearest Isuzu Dealer. The Isuzu Dealer will be able to duplicate your key.
- If you resell the vehicle, be sure to hand over the plate with key code to the new owner together with the vehicle.

Key with Immobilizer Transponder Chip v

The key contains an immobilizer transponder chip.

The immobilizer anti-theft system allows the engine to be started only when it receives signals from the transponder of the pre-registered key.

However, even when using the pre-registered key, you might not be able to start the engine in the cases listed below. If the engine fails to start due to a metal key holder, remove the key holder and then try again; first turn the starter switch to the "ACC" or "LOCK" position, then turn to the "START" position to start the engine.

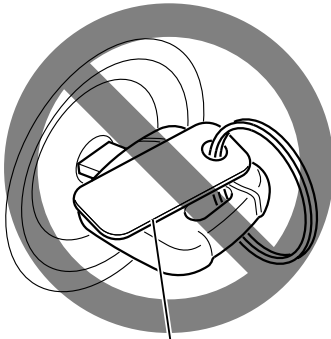

Metal key ring etc.

- There is a facility nearby that is emitting strong radio waves.
- A metallic object is touching or covering the handle of the key.

WARNING

- Do not keep the starter switch in the "START" position for more than about 10 seconds. Operating the starter for too long might cause battery failure or might result in overheating and even a fire.

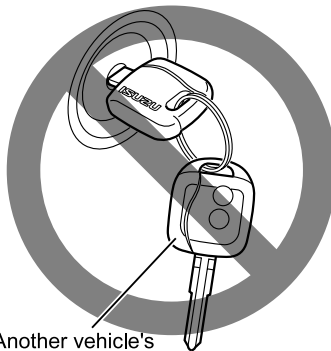

Another vehicle's transponder key

- Another vehicle's transponder key is near your key.

ADVICE

- Should you lose your transponder key, contact the nearest Isuzu Dealer.
- Do not leave the transponder key on the dashboard or any other surface where the key might be exposed to high temperatures (exceeding 60°C /140°F).
- Do not place a magnetic object close to the transponder key.

Keyless Entry System v

Remote control operating range

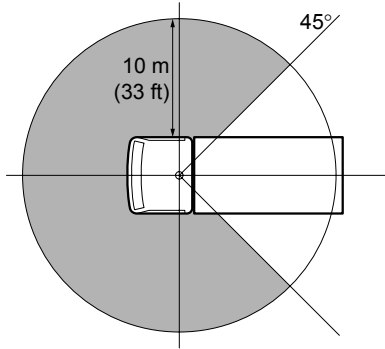

The keyless entry system allows you to lock/unlock the doors by simply pressing the remote control button rather than inserting the key into the lock.

The remote control unit works within a 10 m (33 ft) radius of the cab center as indicated in the figure.

Unlocking and Locking the Doors

Remote control unit

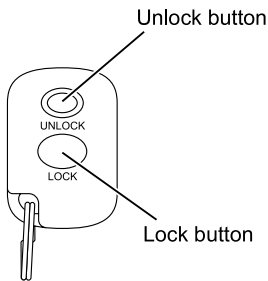

Unlocking

Press the door unlock button of the remote control unit for 1 second or longer. The vehicle's keyless entry system causes the right and left turn signal lights to simultaneously flash twice upon receiving the signals from the remote control unit. If the doors are unlocked with the dome light switch in the "DOOR" position, the dome light comes on for about 10 seconds.

Locking

Press the door lock button of the remote control unit for 1 second or longer. The vehicle's keyless entry system causes the right and left turn signal lights to simultaneously flash once upon receiving the signals from the remote control unit. If the dome light is on with its switch in the "DOOR" position, the dome light goes out.

**ADVICE**

- Should you lose the remote control unit, please contact your Isuzu Dealer.
- After locking the doors using the remote control unit, be sure to check that they are locked by pulling the door handles.
- Avoid getting water on the remote control unit, dropping it, hitting it against another object, or stepping on it; otherwise, the remote control unit could malfunction.
- Do not leave the remote control unit on the dashboard or any other surface where the unit might be exposed to high temperatures (exceeding 60°C/140°F). Doing so may result in shorter battery life or malfunction of the remote control unit.
- Repeatedly locking and unlocking the doors using the remote control unit 10 or more times in succession will trigger the protection circuit in the system, preventing the unit from working. If this happens, wait for a while. The system will then work normally.
- If the keyless entry system fails to operate normally, lock and unlock the doors using the key and have the system inspected by your Isuzu Dealer.

**NOTE**

- The lock or unlock buttons on the remote control unit must be fully pressed for more than 1 second to work.
- If you do not open any doors within about 30 seconds after pressing the unlock button to unlock the doors, the automatic locking function of the system will lock the doors again to prevent theft.
- In areas near a TV tower, electric power plant, radio station, etc. or under any conditions involving strong electrical disturbances, the remote control unit operating range might change or the keyless entry system might not work.
- The keyless entry system does not operate in the following cases:
 - The starter switch is in the "ON" position.
 - The key is inserted in the starter switch.
 - One of the doors is open.

Replacing the Battery in the Remote Control Unit

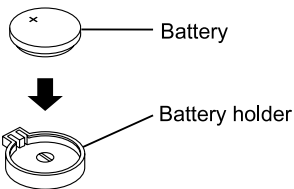
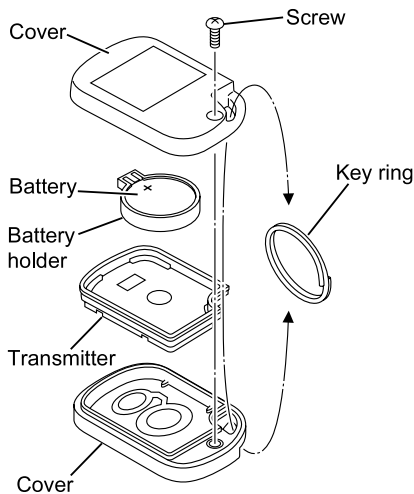

1. Remove the key ring from the remote control unit. Remove the cover by removing the screw with a small screwdriver.
2. Take out the battery holder, and then remove the battery from the holder.

3. Install a new battery (CR2032, 3 V) in the battery holder with the "+" mark side facing up and place the holder in position in the cover.



ADVICE

- When closing the cover, check that there is no dust, hair or anything else caught underneath it. A poorly sealed remote control unit could become deteriorated.

4. Close the cover, and then fasten the cover with the screw. Install the key ring on the remote control unit.

**CAUTION**

- When changing the battery, use only a battery of the same type as the original battery, or an equivalent. Otherwise, there is a risk of explosion.
- Do not place the battery in direct sunlight, or near a fire or other sources of heat.
- Be sure to install the battery with the "+" side up and the "-" side down. Incorrect installation will result in leakage of chemicals from inside the battery or other operational problems.

**ADVICE**

- Dispose of an old battery by conforming to the environmental protection requirements in your country and take special care to prevent any danger to children.

**NOTE**

- The battery life varies depending on how the remote control unit is used.
- The battery has reached its end of life when the remote control unit works intermittently or does not work at all. Replace the battery as soon as this happens.

Opening and Closing Doors

**CAUTION**

- Be sure to do the following whenever you leave the vehicle: 1) Fully engage the parking brake. 2) Stop the engine. 3) Lock the doors.
- When you close the door after sitting behind the wheel, check that the door is fully closed. Driving with any door ajar is very dangerous.
- Before opening the door when climbing into or out of the cab, carefully check all areas around the vehicle for safety, especially the area at the rear of the vehicle.
- Never leave the key in the vehicle.
- Tilt the cab only after fully closing the doors.

Front Doors (NLR/NNR/NPR/NQR/NPS Models)

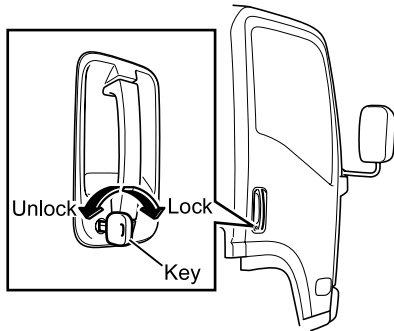

Locking and Unlocking the Door from Outside Using the Key

Turn the key toward the front of the vehicle to lock the door and turn it toward the rear of the vehicle to unlock it.

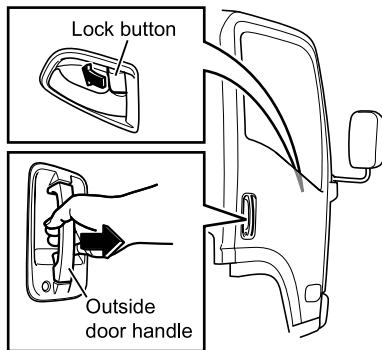

Locking the Door from Outside without Using the Key

First, push the lock button on the inside door handle forward and then close the door while keeping the outside door handle raised.



NOTE

- Before closing the door, be sure to check that you have the key with you.

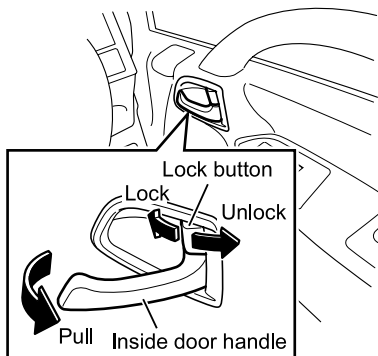

Locking and Unlocking the Door from Inside

Push the lock button forward to lock the door; pull the lock button backward to unlock it. After unlocking the door, open it by pulling the inside door handle.

Power Door Lock (Central Door Lock) **How the Power Door Lock System Operates:**

When you lock or unlock the driver's door using the key or by operating the lock button, the power door lock system will automatically lock or unlock all doors simultaneously.

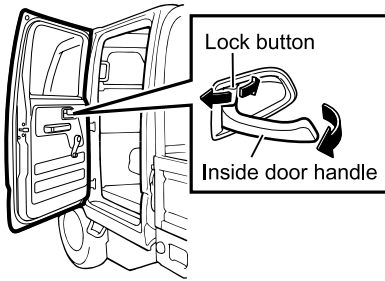
Rear Doors (Crew Cab Model)**NLR/NNR/NPR/NQR/NPS models****Locking the Door from Outside**

Push the door lock button forward and then close the door; the door will be locked.

Locking and Unlocking the Door from Inside

Push the door lock button forward to lock the door and pull the lock button backward to unlock it.

Power Windows v

The power windows operate only when the starter switch is in the "ON" position. Open each door window by pressing the power window switch; close each one by raising the switch.





WARNING

- Before closing the windows, make sure that there is no risk of a hand, head or anything else being trapped in the moving window. Failure to do so could result in serious injury. This is especially true when a child is with you.

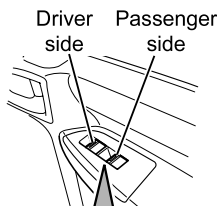
Window Switches on Driver's Door

NLR/NNR/NPR/NQR/NPS models



	OPEN	CLOSE
Driver side		
Passenger side		

To Open the Driver's Window

Lightly pressing the driver-side window switch will lower the driver's window until the switch is released (manual mode operation). When the switch is firmly pressed, the window will lower completely without the need to press the switch continuously (automatic mode operation). If you want to stop the automatic movement of the window before it lowers completely, raise the switch lightly.

To Close the Driver's Window

Lightly raising the driver-side window switch will cause the driver's window to move up until the switch is released.

To Open the Passenger's Window

The passenger's window continues to lower while the passenger-side switch on the driver's door is being pressed.

To Close the Passenger's Window

The passenger's window continues to move up while the passenger-side switch on the driver's door is being raised.

Window Switches on Passenger's Door and Rear Doors

NLR/NNR/NPR/NQR/NPS models
(Passenger side)

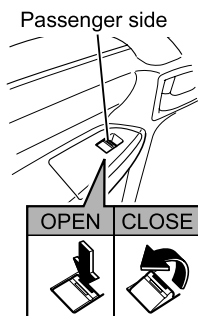

CAUTION

- Be sure to warn passengers, especially in the case of a child, not to let any part of the body become trapped or caught in a moving window.

The window continues to lower while the window switch is being pressed and continues to rise while the switch is being raised. It will stop moving at any position when the switch is released.



NOTE

- When the rear power window lock switch is in the "LOCK" position, it is not possible to open and close the rear windows.

Window switch on rear doors
(Crew cab model)

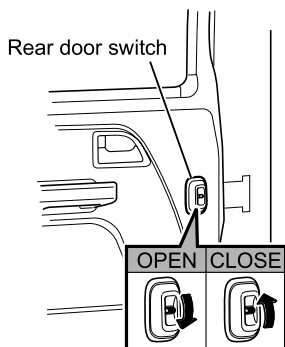

Window Switches on center of dashboard (Crew Cab model)

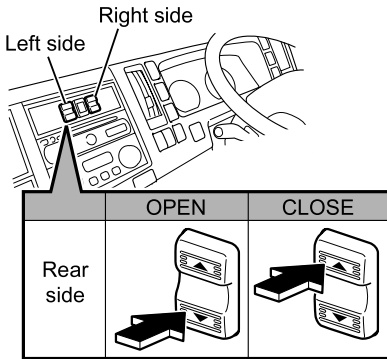

To Open a Rear Window

The window glass will move downward while you are pushing the bottom part of the switch.

To Close a Rear Window

The window glass will move upward while you are pushing the top part of the switch.

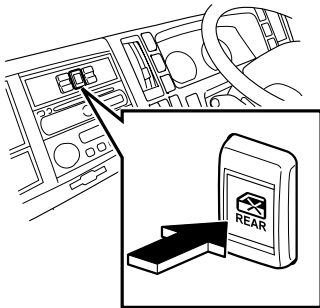

To Lock Rear Power Windows

If you push the rear power window lock switch, only the driver's window and front passenger's window will be operable. To cancel the rear power window lock, push the switch again.

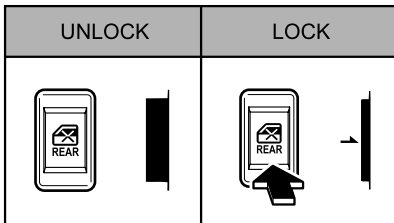

CAUTION

- Use the rear power window lock switch to "lock" the rear power windows when carrying a child in the vehicle. By doing so, you can prevent the child from operating the rear power windows and causing an accident.

Fuel Tank Filler Cap

WARNING

- Be sure to place the starter switch in the "ACC" or "LOCK" position to shut down the engine before refueling the vehicle. Refueling while the engine is running could cause a fire in your vehicle.
- When refueling, never smoke or place any ignition source nearby. There is a risk of fire.
- After refueling, make sure that the fuel tank filler cap is tightly closed.

CAUTION

- Always use only a low-sulfur diesel fuel (50 ppm or lower sulfur content) or super-low-sulfur diesel fuel (10 ppm or lower sulfur content). The use of a poor-quality diesel fuel, mixing such an additive as water remover to the fuel in the tank, or filling the tank with gasoline, kerosene or an alcohol-based fuel or its mixture with a diesel fuel will badly affect the fuel filter and result in lubrication problems in fuel-lubricated components of the injectors. In addition, this practice can also impair the operation of the engine and the diesel particulate defuser (DPD), the exhaust emission cleaning system, possibly leading to breakdown of the engine-related systems. If an incorrect fuel should accidentally be added, drain all fuel from the system. Failure to observe this precaution can result in a fire or permanent damage when the engine is started.
- The use of any fuel other than a low-sulfur or super-low-sulfur diesel fuel in a DPD-equipped vehicle may violate the relevant regulations enforced in certain countries or regions.
- Be sure to slowly open the fuel tank filler cap. If you open it quickly, fuel may spurt out.

Using Self-service Filling Stations

→ Refer to page 2-19

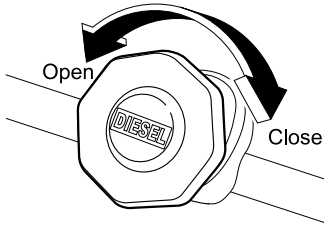

How to Open and Close the Fuel Tank Filler Cap (without Key Lock)

1. Eliminate static from your body before opening the fuel tank filler cap.
2. Slowly turn the cap counterclockwise to open it.
3. Refuel the tank.
4. Align the grooves on the cap and tank and turn the cap clockwise to close it.
5. Check that the cap is tightly closed.



WARNING

- If the fuel tank filler cap is not tightly closed, leaking fuel could start a fire while driving.

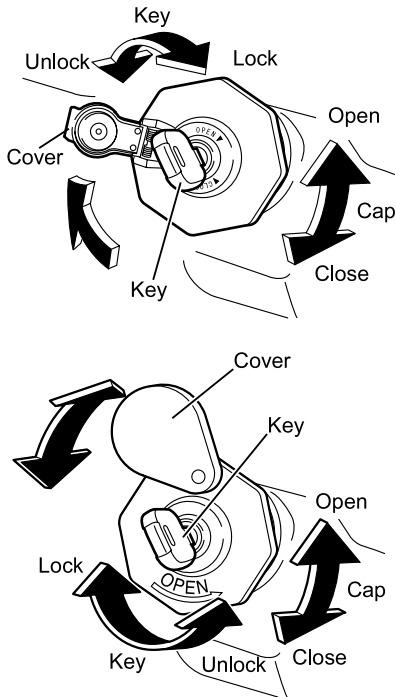

Opening and Closing the Fuel Tank Filler Cap (with Key Lock)

1. Eliminate static from your body before opening the fuel tank filler cap.
2. Open the cover, then firmly insert the key and turn it to the "OPEN" position.
3. Slowly turn the cap counterclockwise to open it.
4. Refuel the tank.
5. Securely screw the fuel tank filler cap onto the fuel tank.
6. Turn the key to the "CLOSE" position to lock the fuel tank filler cap.
7. Pull the key out, then make sure the fuel tank filler cap is securely closed.

WARNING

- If the fuel tank filler cap is not tightly closed, leaking fuel could start a fire while driving.

ADVICE

- When opening or closing the fuel tank filler cap, be sure to grasp the fuel tank filler cap itself, not the key. If you try to turn the fuel tank filler cap using the key, you could damage the key.

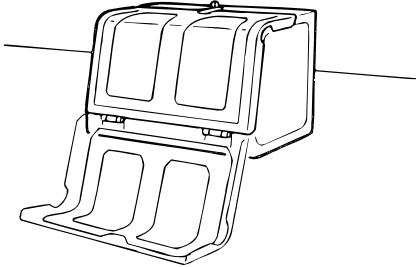
Tool Box 

The tool box is located on the vehicle's outer chassis (either in the middle or near the rear).

**CAUTION**

- Securely close the tool box so the lid does not come open while the vehicle is moving.

Seats

The driver's seat must be adjusted so that when you sit well back in the seat, you can fully depress the pedals without moving your back from the seatback, and you can operate the steering wheel easily and freely. After making adjustments, check that the seat is completely locked.

Adjusting the seat for a correct driving posture is a fundamental part of safe driving.

Make sure you can turn the steering wheel easily.



Make sure you can adequately press the pedals.

WARNING

- Adjust the seat only before you start driving. Adjusting the seat while the vehicle is in motion must be avoided not only because the unlocked seat will move back and forth unstably, preventing you from taking the correct position, but might also cause you to lose control of the vehicle, possibly resulting in an accident.
- Try to move the seat without unlatching it after making adjustments to check that it is completely locked. A loosely locked seat may move unexpectedly and your position might then become unstable; this could lead to an accident.
- Do not place a cushion or similar object between your back and the seatback. Doing so not only affects the stability of your driving position but also prevents the seat belt from working effectively in the event of a collision.
- Before making adjustments, check that the seat rails are free of anything that could obstruct the locking of the seat. Be careful that your hand or foot does not become trapped in the seat or rails when adjusting the seat.

Driver's Seat

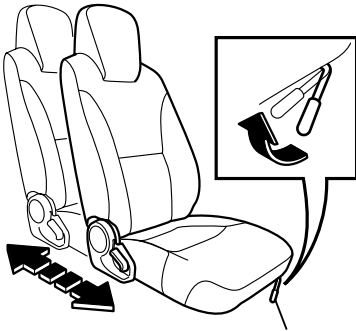

Fore-aft position adjustment lever

Forward/backward Adjustment

While raising the lever, move the seat forward or backward. Release the lever when the seat is in the desired position. After making adjustments, try to move the seat back and forth to check that it is fully locked.

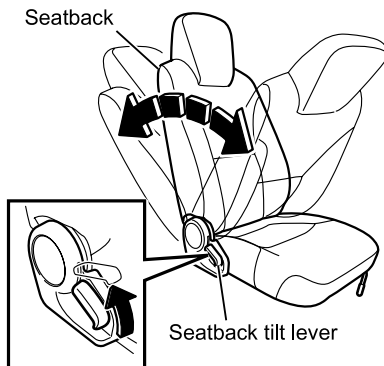

Seatback

Seatback tilt lever

Reclining Adjustment

To recline the seatback, raise the seatback tilt lever and gently lean back to the desired position.

To move the seatback forward, lean forward with your back slightly clear of the seatback and raise the lever. After making adjustments, check that the seatback is fully locked.

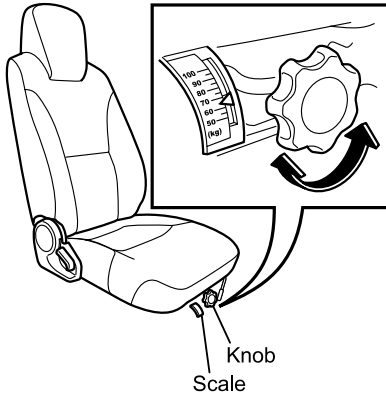

Suspension Adjustment

Before sitting on the seat, use the knob to adjust the suspension to suit your weight. Turn the knob clockwise to move the pointer down the scale and counterclockwise to move it up the scale. The pointer should be alongside your weight on the scale.



NOTE

- The range of adjustment is 50–100 kg (110–220 lb). If your weight is outside this range, the suspension may not be fully effective. However, you will be able to sit in the correct position for driving.

Passenger Seat/Centre Seat

You can tip the seatback forward if you pull forward the lever at the side of the seatback.

Normally, you should keep the seatback in the raised position.

Passenger's seat

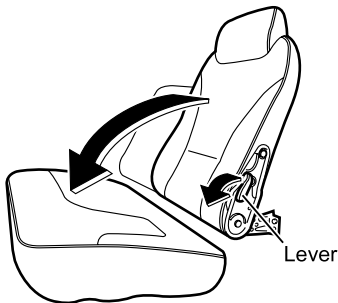

Centre seat

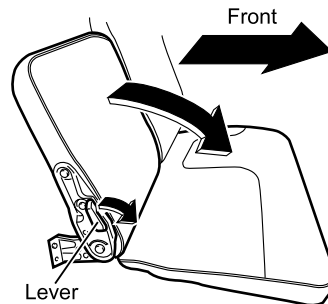

CAUTION

- Baggage must not be placed on the centre seat. If the baggage falls on the floor when the vehicle is braked, it may prevent the driver from operating the pedals.

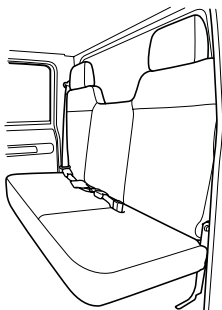
Rear Seats ▼

Do not remove the seat cushion except when taking out or stowing onboard tools.

Tools → Refer to Page 7-7

**CAUTION**

- Do not drive with the seat cushion removed. The seat would not be stable, which could lead to an accident.

**NOTE**

- The rear seat headrests are not adjustable.
- Do not use the rear seats with the headrests removed during driving.

Fully Adjustable Steering

The steering wheel is adjustable up and down as well as forward and backward.

WARNING

- After adjusting the steering wheel, try moving it up and down to make sure it is fully locked before you drive the vehicle.
- Adjust the steering wheel only when the vehicle is not in motion. Steering wheel adjustment on a moving vehicle is very dangerous, since a vertically moving steering wheel prevents the driver from properly controlling the vehicle.

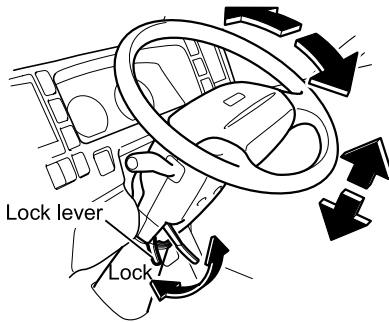

Adjustment

1. Lift the lock lever toward you to unlock the steering column.
2. Sit in the correct driving position, and then move the steering wheel up and down and forward and backward to select the optimum steering wheel position.
3. Firmly lock the steering wheel at the selected position by moving the lock lever to the lock position.

Mirrors

Sit in the correct driving position on the properly adjusted seat, and then check each mirror to ensure that it provides a proper view of the rear, the sides, the area just in front of the vehicle, and the area directly opposite to the driver's seat. Make adjustments if necessary and clean any dirty mirrors.

Inside Mirror

NLR/NNR/NPR/NQR/NPS models

Adjustment

Move the mirror to a position where it provides a proper rear view.

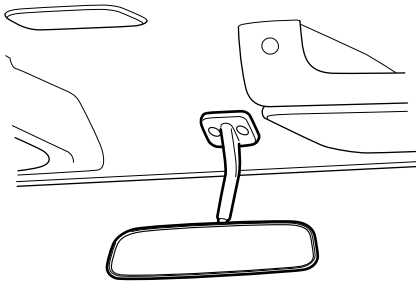

CAUTION

- Adjust the mirror when the vehicle is stationary, not while the vehicle is in motion.

Outside Rearview Mirrors

After properly adjusting your seat for the correct driving position, adjust the mirrors indicated below so that they provide adequate views for checking the rear, the side and the areas just in front and immediately to the side of the vehicle by moving each of the mirrors.

Door mounted mirror

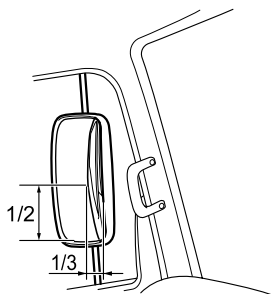

Outside Rearview Mirror

Lateral-direction: Adjust the mirror so that you can see the vehicle's side including the cargo bed within the inner one-third of the mirror.

Vertical-direction: Adjust the mirror so that you see the rear bottom corner of the vehicle halfway up the height of the mirror.

**CAUTION**

- Adjust the mirrors when the vehicle is stationary, not while the vehicle is in motion.
- When checking the rear of the vehicle with mirrors, be careful that this does not distract your attention from the traffic ahead.
- Rearview mirrors may make the vehicle behind you appear farther away than it really is. Use these mirrors very carefully until you are able to correctly determine distances from the images.
- Keep the mirrors in mind when passing another vehicle on a narrow road, moving the vehicle into a garage or driving near pedestrians.
- Do not drive with the mirrors folded.

Seat Belts

The protection provided by seat belts might be significantly reduced if they are not fastened properly; in certain cases, improperly fastened seat belts can even play a role in causing injury to the wearer. Seat belts must be worn not only by the driver but also by the passenger(s) before the vehicle starts moving. You should be fully acquainted with the proper use of seat belts and important points to be respected as described in the following pages. Familiarizing yourself with the correct use of seat belts is essential for your safety.

 **WARNING**

- Seat belts must always be fastened BEFORE starting to drive.
- Seat belts provide full protection only when the driver and passenger(s) fasten them while sitting upright and fully back on the seat.
- Wearing a seat belt with the seatback excessively reclined could be very dangerous in a collision or sudden stop since the occupant may slide under the belt and be seriously injured. Seat belts work best only when the occupant is sitting well back and straight up in the seat.
- Be sure to insert the latch plate into the buckle until a click is heard. An incompletely inserted latch plate is dangerous in the event of a collision or sudden stop.
- Do not run the seat belt over your face, chin or neck.
- Wear the seat belt as low as possible around the hips, not around the waist. A seat belt running over the waist would press the abdomen with a strong force and could increase the likelihood of injuries in a collision or sudden stop.
- Do not use a seat belt for a small child if the belt is on or very close to the child's neck or chin. Also, do not use a seat belt if it does not fit snugly over the child's hips because restraining the child under those conditions could be dangerous in the event of a collision or sudden stop. Instead, use an appropriate child restraint system available on the market. For further details, please contact your Isuzu Dealer.
- Use a child restraint system that fits the size of the infant or child. Install the system according to the manufacturer's instructions.
- Remove any twists in the seat belt before fastening it. A seat belt with twists will not provide full protection because it cannot disperse shocks efficiently in the event of a collision or sudden stop.
- Expectant mothers or people suffering from chest or abdominal conditions should check with their doctor for specific recommendations about wearing seat belts.
- Do not use one seat belt for more than one person. If worn by more than one person, the seat belt would not work effectively in a collision or sudden stop.
- Have seat belts inspected and, if necessary, replaced by the nearest Isuzu Dealer when the webbing becomes frayed or worn and/or when the buckle or other mechanical parts fail to work properly.
- If your vehicle has been involved in a collision, the seat belts worn at the time may have lost their original strength due to impact even if they appear intact. These seat belts must be inspected and, if necessary, replaced by the nearest Isuzu Dealer.
- Be careful to keep the buckles and retractors free of dust and foreign matter.

WARNING (Continued)

WARNING (Continued)

- Wearing seat belts is a legal requirement. The driver is responsible not only for wearing a seat belt himself/herself but also for prompting all passengers to wear their seat belts. It is necessary, however, to check with a doctor about the appropriateness of a seat belt for an expectant mother or a passenger with a chest/abdominal condition.

Seats → Refer to page 3-17

Seat Belt Warning Light

→ Refer to page 4-34

Seat Belt Care

→ Refer to page 7-152

Three-Point Seat Belts

Every seat except the center seat on your vehicle is equipped with a three-point seat belt. The seat belt extends or retracts freely if the wearer moves slowly, but it locks and restrains the occupant during forward force caused by the occupant's body following a strong shock. Adjust the driver's shoulder belt for proper position by means of the shoulder anchor.

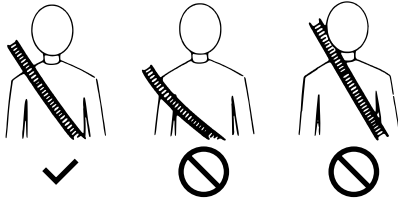
**WARNING**

- The shoulder belt should be adequately positioned on your shoulder but should not touch your neck and/or face. The shoulder belt could harm you in a collision or sudden stop if it is in contact with your neck and/or face.

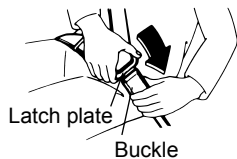
**To Fasten**

1. Sit on the seat in the correct driving position.
2. Pull out the seat belt holding the latch plate. After checking that there are no twists in the belt, insert the latch plate into the buckle until it clicks.
3. Position the lap belt so that it snugly fits as low as possible on the hips.

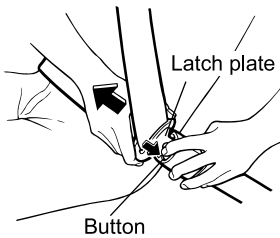

To Unfasten

Push the button on the buckle. As the belt automatically retracts, let it be taken up slowly by holding on to the latch plate until the belt is fully retracted.



ADVICE

- While being automatically retracted, the seat belt could damage a nearby window or interior trim unless the latch plate is properly held. Hold the latch plate to ensure that the belt is taken up slowly.
- Before closing the door, check that the retracted seat belt is taut. A slack belt could become trapped in the door or seat rail.
- When the passenger's seat belt is fully taken up (or not pulled out), check that the stopper is holding the belt in a fully taut state.

**CAUTION**

- If you repair any components around the steering wheel, instrument panel, center console and brake/clutch pedal or on the seat belts, or if you install an audio system or other equipment, the seat belt with pretensioner and SRS airbag system may be adversely affected, possibly causing the driver's seat belt (and the passenger's seat belt, if the vehicle is equipped with a passenger's airbag) to unintentionally retract or the driver's airbag (and the passenger's airbag, if equipped) to suddenly deploy, resulting in injury. Be sure to have any repair or installation done by your Isuzu Dealer.

**NOTE**

- The driver's seat belt and the passenger's seat belt (if the vehicle is equipped with a passenger's airbag) feature pretensioner and load limiter functions.
- The three-point seat belts are provided with an emergency locking retractor (ELR) function.

[ELR function]

- The ELR normally allows the seat belt to move in and out freely as the occupant moves. However, it locks the seat belt to restrain the occupant when a forward force resulting from a collision or sudden stop acts on the occupant.
- The ELR also locks the seat belt when the belt is pulled out quickly. If this happens, allow it to retract once and then pull it out slowly.

[Load limiter function]

- The load limiter allows the seat belt to extend while maintaining the load working on the belt at a constant level. This helps alleviate the shock applied on the occupant's chest.

**Seat Belt with Pretensioner
and SRS Airbag System**

→ Refer to page 4-142

Two-Point Seat Belt (Centre Seat)

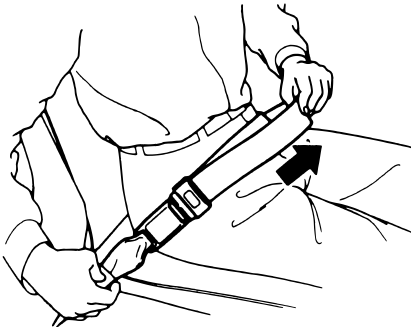
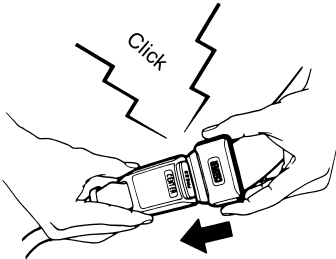
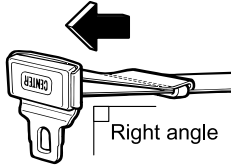
**To Fasten**

1. Sit on the seat in the correct position.
2. Pull out the latch plate side of the belt a little longer than necessary. (Placing the latch plate at right angles with the belt makes this easier.)
3. After checking that there are no twists in the belt, insert the latch plate into the buckle until it clicks.

4. Position the seat belt across the lap as low as possible on the hips. Pull the fold-back end of the belt (upper side) until the belt is adjusted to a snug fit.



Keep as low on hip bone as possible

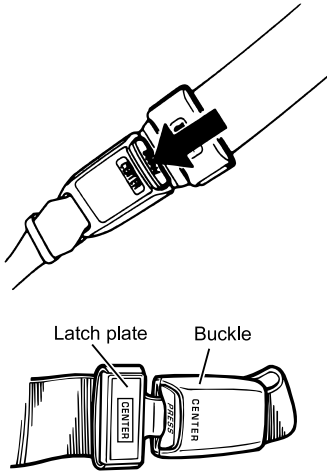

To Unfasten

Push the button on the buckle to unfasten the belt.



NOTE

[Centre seat belt design to prevent incorrect fastening]

- The centre seat belt (length-adjustable two-point belt) is designed so that it cannot be connected with any of the window-side seat belts (three-point seat belts with ELR).

In addition, both the latch plate and buckle of the centre seat belt are identified by "CENTER" marks to prevent incorrect fastening of the centre seat belt.



CONTROLS AND INSTRUMENTS

4

STARTING AND STOPPING THE ENGINE

4-3

**INSTRUMENTS, WARNING LIGHTS AND
INDICATOR LIGHTS**

4-7

SWITCHES

4-59

DRIVING CONTROLS

4-75



STARTING AND STOPPING THE ENGINE

• Starting the Engine	4-4
• Stopping the Engine	4-6

Starting the Engine

Make sure that the switches, including those for the windshield wiper, light control and air conditioner, are in the "OFF" position.

Turn the starter switch to the "ON" position to check that the warning and indicator lights turn on normally and the fuel level is proper.

Starting the Engine

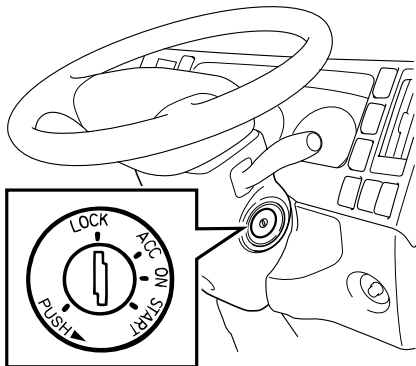

WARNING

- Do not keep the starter switch in the "START" position for more than about 10 seconds. Operating the starter for too long might cause battery failure or might result in overheating and even a fire.

Starter Switch → Refer to page 4-60

CAUTION

- If your vehicle is equipped with a manual transmission, firmly engage the parking brake when you sit in the driver's seat before starting the engine. Also, be sure to start the engine while pressing the clutch pedal and after making sure that the gearshift lever is in the "N" position.
- If your vehicle is equipped with a AMT system, firmly engage the parking brake when you sit in the driver's seat, check that the gearshift lever is in the "N" position and the shift indicator shows "N", and firmly press the brake pedal before starting the engine.
- If you lean through the window from outside of the vehicle to start the engine, the vehicle may start moving if the gearshift lever is in any position other position than "N". This is very dangerous. Never start the engine that way.

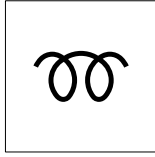
Glow plug indicator light

1. If your vehicle is equipped with a manual transmission, fully press the clutch pedal.
If your vehicle is equipped with a AMT system, make sure that the gearshift lever is in the "N" position and firmly press the brake pedal.
2. When the starter switch is turned to the "ON" position, the glow plug indicator light comes on and it goes out in about 0.5 seconds when the engine is warm, or in about 4 seconds when the engine is cold.
3. After confirming that the glow plug indicator light has gone out, turn the starter switch to the "START" position to start the engine.
If your vehicle is equipped with an idling control knob, use the knob to stabilize the engine speed when the engine runs rough during warm-up, regardless of the position of the warm-up switch. When your vehicle has warmed up, fully turn the idling control knob counterclockwise and run the engine at idle.

**ADVICE**

- At low ambient temperatures, a cold engine may emit more smoke (white smoke) than usual.
- If you place the warm-up switch in the "ON" position, the engine can be warmed up faster and the exhaust smoke can be reduced.
- In certain situations where the starter switch is placed in the "ON" position or the brake pedal is pressed several times during idling, the vacuum may be depleted and a warning buzzer may sound.

Brake Booster Warning Light

→ Refer to page 4-36

**NOTE**

[Preheating]

- Diesel engines are compression ignited, which makes them difficult to start when they are cold because the compression alone cannot create a temperature high enough for fuel to ignite. "Preheating" means warming the compressed air inside the combustion chambers to facilitate engine starting. Be sure to start the engine after the glow plug indicator light has gone out.

Stopping the Engine

Firmly apply the parking brake.

With the accelerator pedal released, turn the starter switch to the "ACC" or "LOCK" position.

**ADVICE**

- Do not shut down the engine immediately after driving the vehicle. Otherwise, a seizure or other failures may result. Before stopping the engine, run the engine at idle for approximately 3 minutes to cool it down after applying the parking brake and making sure of the following: The gearshift lever is in the "N" position (a manual transmission equipped model), or the gearshift lever is in the "N" position and the shift indicator shows "N" (a AMT equipped model).
- To prevent the battery from going dead, turn the starter switch to the "ACC" or "LOCK" position after stopping the engine. If you leave the vehicle for an extended period of time, place the starter switch in the "LOCK" position.

INSTRUMENTS, WARNING LIGHTS AND INDICATOR LIGHTS

• How to Read the Instruments (Instruments Layout)	4-8
• Speedometer	4-9
• Analog Tachograph <input type="checkbox"/>	4-11
• Tachometer	4-11
• Engine Coolant Temperature Gauge	4-12
• Fuel Gauge	4-13
• Hour Meter <input type="checkbox"/>	4-14
• Warning and Indicator Lights Layout	4-15
• Multi-Information Display (MID) <input type="checkbox"/>	4-17
• Warning and Indicator Lights	4-34
• Warning Buzzer	4-58

How to Read the Instruments (Instruments Layout)

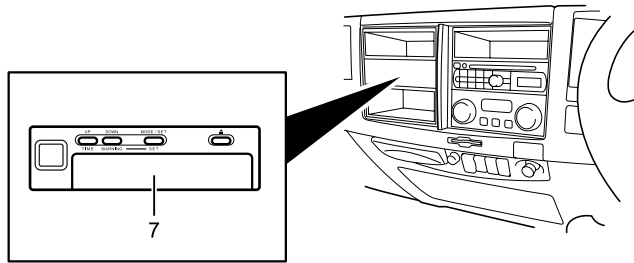
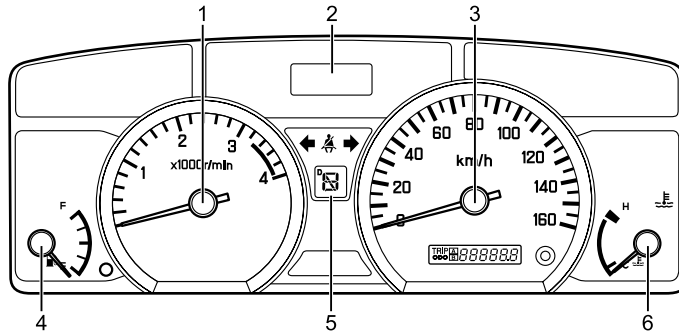

No.	Name	Reference page
1	Tachometer	4-11
2	<input type="checkbox"/> Multi-Information Display (MID)	4-17
3	Speedometer	4-9
4	Fuel gauge	4-13

No.	Name	Reference page
5	<input type="checkbox"/> SA Shift indicator	4-79
6	Engine coolant temperature gauge	4-12
7	<input type="checkbox"/> Analog Tachograph	4-11

Speedometer

Model without multi-information display (MID)

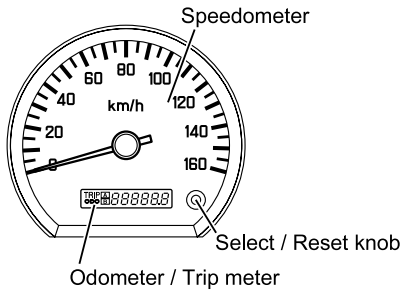

The speedometer indicates the vehicle speed in km/h or MPH. The speedometer is an integral unit with the odometer/trip meter. Each time you press the reset button lightly with the starter switch in the "ON" position, the odometer/trip meter shows "ODO", "TRIP A" and "TRIP B" in this sequence and one at a time to indicate the selected meter.

Odometer

The total distance traveled by your vehicle is indicated in km if the speedometer is graduated in kilometer units. The total distance traveled by your vehicle is indicated in miles if the speedometer is graduated in both mile and kilometer units. When 999,999 kilometers (or 999,999 miles) are exceeded, "B" is displayed.

Model with MID

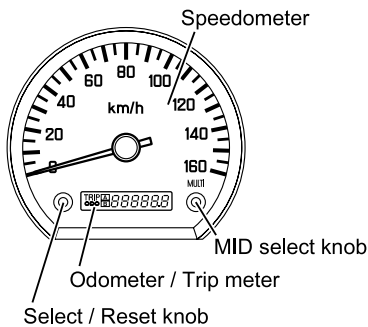

Trip Meter

Use the trip meter to learn the distance between the specific points or the distance traveled during a specific period of time. In the case of a speedometer graduated in kilometers, the value to the right of the decimal point indicates 100-m units, whereas in the case of a speedometer graduated in both miles and kilometers, this value indicates 0.1-mile units. In addition, two separate distances can be associated with "TRIP A" and "TRIP B". Use the two trip meters by switching between "TRIP A" and "TRIP B" as appropriate. If you want to reset the trip meter, use the select/reset knob to select and display the trip meter that you want to reset. The starter switch should be in the "ON" position. Then, press and hold the knob down for at least one second.

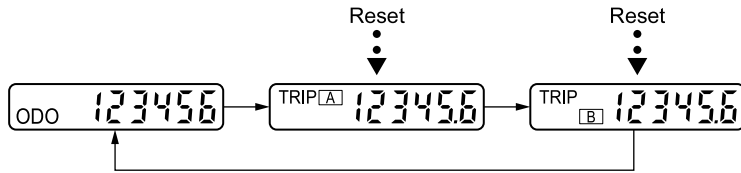

→ :Select / Reset knob-Press once

••▶ :Select / Reset knob-Press and hold (more than 1 second)



NOTE

- When you turn the starter switch to the "ON" position, the odometer/trip meter shows what was displayed the last time you turned the switch to the "LOCK" or "ACC" position.
- You can set the odometer to display on the odometer/trip meter each time you turn the starter switch to the "ON" position. To do this, turn the starter switch to the "LOCK" or "ACC" position while the odometer is being displayed, and then, with the select / reset knob pressed, turn the starter switch to the "ON" position. Within 3 seconds after turning the switch to the "ON" position, turn the starter switch back to the "LOCK" or "ACC" position. Follow the same procedure to cancel the setting.

Tachometer

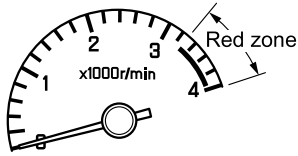

The tachometer indicates the engine speed in revolutions per minute (r/min). (Graduation "1" on the scale indicates 1,000 r/min.) The red zone indicates a range of dangerous engine speeds beyond permissible levels.

Do not drive your vehicle with the needle of the tachometer in the red zone.



ADVICE

- Exercise extreme caution when shifting down on a steep downslope. The engine speed may easily exceed the critical speed, which can seriously damage the engine.

Gear Shift Lever → Refer to page 4-78

Engine Coolant Temperature Gauge

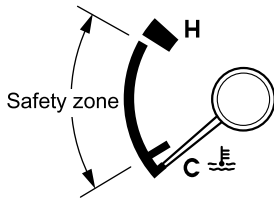

Model without MID

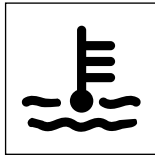

Model with MID



With the starter switch in the "ON" position, this gauge indicates the temperature of the engine coolant. "C" means cold while "H" means hot. If the engine overheats, the engine overheat warning light comes on (a model without multi-information display (MID)) or the warning message is indicated (a model with MID) and a warning buzzer sounds. During operation, the needle should stay in the safety zone.



ADVICE

- If the needle goes up above the upper limit of the safety zone and enters the "H" zone while you are driving, the engine is likely to overheat. Immediately pull safely off the road out of the way of any traffic and take the necessary actions to deal with engine overheating.
- If the needle nears the "H" zone but is still in the safety zone, this is not a problem. But, check the coolant level in the reservoir. Add coolant as required.
- The engine can seize up if it is stopped immediately after driving. Take appropriate actions for engine overheating.

Engine Coolant → Refer to page 7-34
When the Engine Overheats

→ Refer to page 8-22

Fuel Gauge



With the starter switch in the "ON" position, this gauge indicates the quantity of fuel remaining in the fuel tank. "F" means the tank is full while "E" means the tank is almost empty.



NOTE

- Make a habit of filling up the fuel tank well before it approaches empty.
- After filling up the fuel tank, it takes a while for the fuel gauge needle to stabilize after the starter switch is turned to the "ON" position.
- If the fuel tank is filled while the engine is off but the starter switch is in the "ON" position, the fuel gauge needle takes a while to show the correct reading. If so, turn the starter switch to the "LOCK" or "ACC" position and then to the "ON" position again.

Low Fuel Warning Light

Model without MID

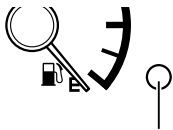

Low fuel warning light

Model with MID



When your vehicle is running out of fuel, the low fuel warning light comes on (a model without a multi-information display (MID)) or the warning is displayed (a model with a MID).



ADVICE

- If your vehicle has run out of fuel, air bleeding procedure must be performed.

Low Fuel Warning Light

→ Refer to page 4-50

When the Fuel Runs Out

→ Refer to page 8-14

Hour Meter **Model with Multi-Information Display (MID)**

This meter indicates how many hours the engine has been run.

The figure(s) on the left side of the decimal point indicate hours while the figure on the right side indicates 1/10 of an hour. This is displayed on the MID. Use the MID select knob to select the hour meter.

Multi-Information Display (MID)

→ Refer to page 4-17

When ERROR is Displayed

→ Refer to page 4-33

Warning and Indicator Lights Layout

Model without multi-information display (MID)

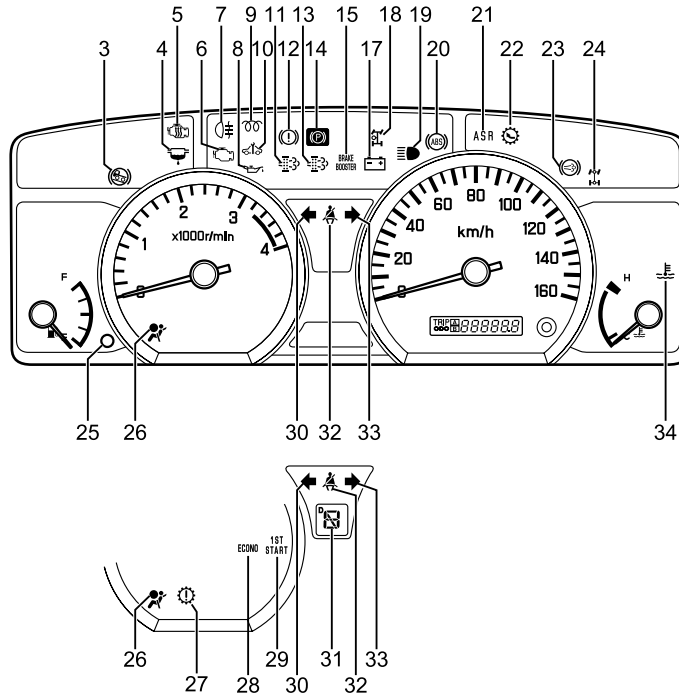

Model with MID

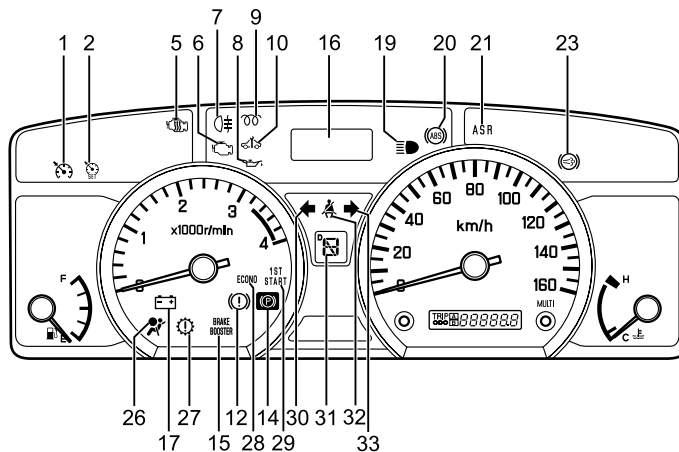

No.	Name	Reference page	No.	Name	Reference page
1	<input type="checkbox"/> V Cruise control main indicator light	4-54	16	<input type="checkbox"/> V MID	4-17
2	<input type="checkbox"/> V Cruise control set indicator light	4-54	17	Generator warning light	4-42
3	<input type="checkbox"/> V HSA indicator light	4-52	18	<input type="checkbox"/> V PTO indicator light	4-55
4	Water separator (fuel filter) warning light	4-43	19	High beam indicator light	4-51
5	<input type="checkbox"/> V Warm-up system indicator light	4-53	20	<input type="checkbox"/> V ABS warning light	4-37
6	Check engine warning light	4-42	21	<input type="checkbox"/> V ASR indicator light	4-53
7	<input type="checkbox"/> V Rear fog light indicator light	4-51	22	<input type="checkbox"/> V Transfer LOW indicator light	4-44
8	Engine oil pressure warning light	4-38	23	Exhaust brake indicator light	4-52
9	Glow plug indicator light	4-53	24	<input type="checkbox"/> V 4WD indicator light	4-55
10	SVS indicator light	4-43	25	Low fuel warning light	4-50
11	<input type="checkbox"/> V DPD automatic regeneration indicator light	4-55	26	<input type="checkbox"/> V SRS airbag warning light	4-34
12	Brake system warning light	4-35	27	<input type="checkbox"/> SA AMT warning light	4-44
13	<input type="checkbox"/> V DPD manual regeneration indicator light	4-55	28	<input type="checkbox"/> SA ECONO mode indicator light	4-54
14	Parking brake warning light	4-51	29	<input type="checkbox"/> SA 1st start mode indicator light	4-54
15	Brake booster warning light	4-36	30	Turn signal and hazard warning flasher indicator light - left	4-50
			31	<input type="checkbox"/> SA Shift indicator	4-79
			32	Seat belt warning light	4-34
			33	Turn signal and hazard warning flasher indicator light - right	4-50
			34	Engine overheat warning light	4-39

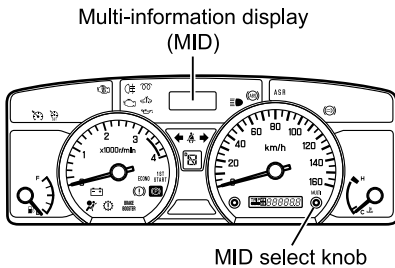
Multi-Information Display (MID) 

The MID in the instrument panel can display the following information.

- Warning and indicator lights
- Operation-related information
- DPD state
- Maintenance data
- Errors

Use the MID select knob to select the desired screen or function.

**CAUTION**

- Warning or indicator lights indicated on the MID can be temporarily cleared (for 60 seconds) by pressing the MID select knob once. However, if the warning light you have cleared is an engine overheat warning or other critical circumstance, never continue driving without taking the necessary actions. Otherwise, you will be in danger of vehicle breakdown or accident. Should any of the critical warning lights comes on, immediately contact the nearest Isuzu Dealer.

Main Routine

This page shows you the basic screens of the MID and what operations are necessary to access these screens.

Use the MID select knob to select the desired screen or function.

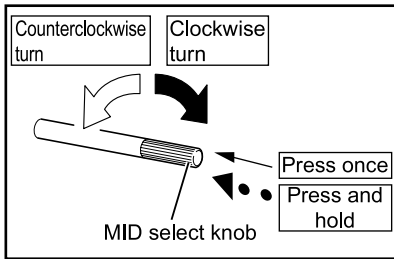



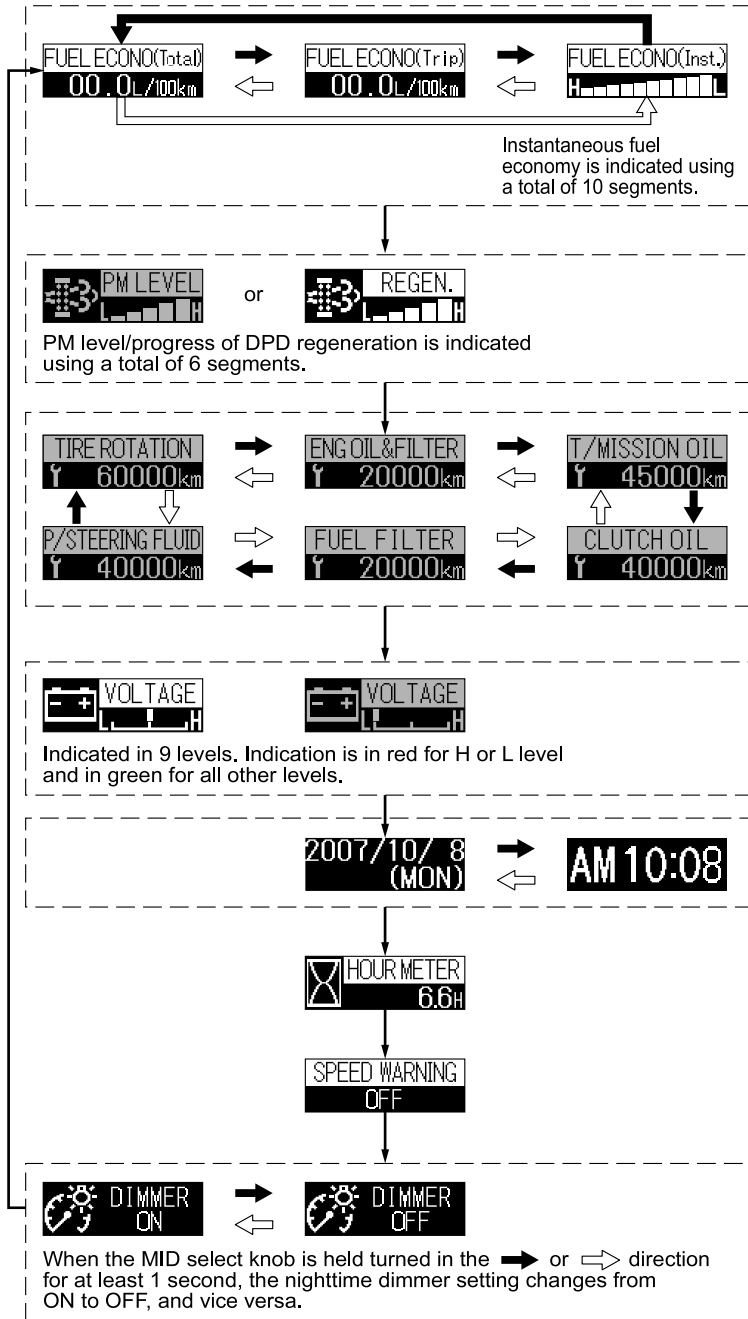





- :MID select knob-Press once
- ▶ :MID select knob-Press and hold
- ➡ :MID select knob-Clockwise turn
- ↶ :MID select knob-Counterclockwise turn



Warning and Indicator Lights Display

Warning and indicator messages are shown on the display to alert you to system failures or to prompt you to necessary checks you should perform while operation-related information is being displayed.

Use the MID select knob to select the desired screen page or function.



Indication	Color	Description	Reference page
 AUTO REGEN.	Green	DPD is being automatically regenerated.	4-158
 CHECKING PM LEVEL	Amber	System is checking if selectable regeneration of DPD is possible.	4-159
 MANUAL REGEN.	Amber	DPD is being manually regenerated.	4-156
 PUSH DPD SWITCH	Amber	Manual regeneration of DPD is needed.	4-155
 LOW FUEL	Amber	Fuel level is too low.	4-50
 WATER SEPARATOR	Red	Water needs to be drained from fuel filter.	4-43
OVER SPEED	Red	Vehicle is running at a speed above the preset speed.	4-38
 OVER HEAT	Red	Engine overheated.	4-39
METER	Red	Instrument has a problem.	4-57
CAN	Red	Error in communication between instrument and connected systems.	4-57
 CHECK E/OIL LVL	Amber	Engine oil level is too low.	4-41

Indication	Color	Description	Reference page
	Amber	Air cleaner needs cleaning soon.	4-41

Operation-Related Information Display

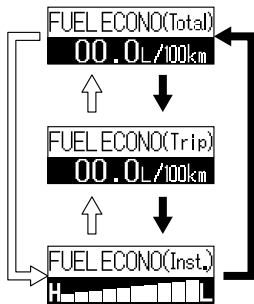
This function displays vehicle operation related information on such items as fuel economy, battery voltage, calendar and clock, which is useful for efficient management of your vehicle operation.



-  :MID select knob-Clockwise turn
-  :MID select knob-Counterclockwise turn

Fuel Economy



The system calculates and stores the distance traveled and fuel consumption while driving to encourage the operator to drive the vehicle economically.

Fuel economy for the "TRIP B" distance is displayed.

Use the MID select knob to select the fuel economy display.

How to Reset the Per Trip Fuel Economy

Per trip fuel economy is also cleared when you reset the "TRIP B" to zero.



Message	Display indication	Color	Display condition
Total fuel economy		Green	This indicates the average fuel economy over the total distance traveled.
Per trip fuel economy		Green	This indicates the fuel economy over a specific distance traveled.
Instantaneous fuel economy		Green	This indicates the fuel economy at a given moment while driving.

Voltmeter

The voltmeter shows the current status of the charge of the battery.

Use the MID select knob to select the voltmeter.

If a voltmeter sign appears with red, have the vehicle checked and serviced at the nearest Isuzu Dealer as soon as possible.

Message	Display indication	Color	Display condition
Voltmeter		Green	Indicates the current status of the charge of the battery.
		Red	This means the battery voltage is too low.
		Red	This means the battery voltage is too high.



NOTE

- During or immediately after the engine is started, an abnormal "L" voltage (red letters on a black background) may be indicated on the MID. If the warning disappears after the engine has started, there is no problem with the battery voltage.

Calendar and Clock

Use the MID select knob to select the calendar or clock to display.

CAUTION

- The calendar and clock can be set only while the vehicle is stationary. When setting the calendar or clock, park your vehicle in a safe place where stopping or parking is permitted and is well clear of traffic.

[Setting the calendar]

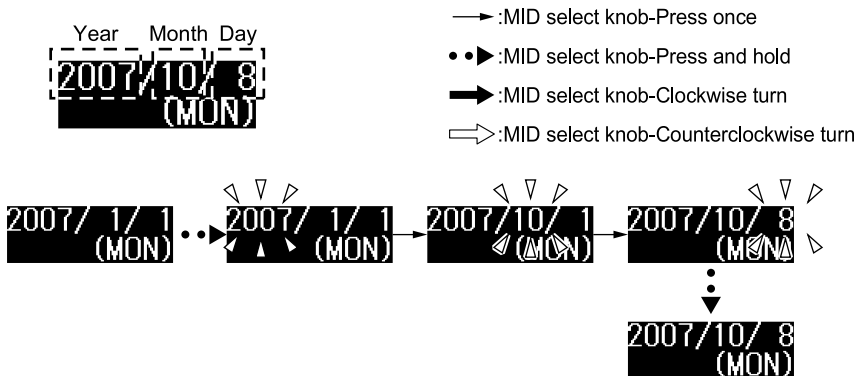

The year, month or day increases as the MID select knob is turned clockwise and decreases as the MID select knob is turned counterclockwise.

1. Press the MID select knob once or more to select the calendar.
2. Press and hold the MID select knob to enter the clock setting screen. The year segment starts flashing.
3. Set the year: Turn the MID select knob clockwise to increase the year and counterclockwise to decrease the year. If you hold the switch after turning it clockwise or counterclockwise, the year continues to increase or decrease until the switch is released.
4. Set the month: While in the year setting screen, press the MID select knob once to switch to the month setting screen. The month segment starts flashing.
5. Turn the MID select knob clockwise to increase the month and counterclockwise to decrease the month. If you hold the switch after turning it clockwise or counterclockwise, the month continues to increase or decrease until the switch is released.
6. Set the day: While in the month setting screen, press the MID select knob once to switch to the day setting mode. The day segment starts flashing.

7. Turn the MID select knob clockwise to increase the day and counterclockwise to decrease the day. If you hold the switch after turning it clockwise or counterclockwise, the day continues to increase or decrease until the switch is released.
8. To complete the calendar setting, press and hold the MID select knob. When the setting is complete, the normal calendar display will resume.

[Setting the clock]

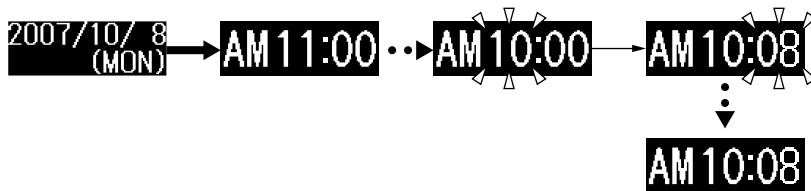

The hour or minute increases as the MID select knob is turned clockwise and decreases as the MID select knob is turned counterclockwise.

1. Press the MID select knob once or more to select the calendar.
2. Turn the MID select knob clockwise to select the clock screen.
3. Press and hold the MID select knob to enter the clock setting screen. The hour segment starts flashing.
4. Set the hour: Turn the MID select knob clockwise to increase the hour and counterclockwise to decrease the hour. If you hold the switch after turning it clockwise or counterclockwise, the hour continues to increase or decrease until the switch is released.
5. Set the minute: While in the hour setting screen, press the MID select knob once to switch to the minute setting screen. The minute segment starts flashing.
6. Turn the MID select knob clockwise to increase the minutes and counterclockwise to decrease the minutes. If you hold the switch after turning it clockwise or counterclockwise, the minutes continue to increase or decrease until the switch is released.
7. To complete the clock setting, press and hold the MID select knob. When the setting is complete, the normal clock display will resume.

Nighttime Dimmer

When the nighttime dimmer is set to ON, MID is dimmed while the headlights are on. Use the MID select knob to select the night time dimmer. If the MID is too dark when driving with the headlights on during daytime, set the nighttime dimmer to OFF.

➡:MID select knob-Clockwise turn



⬅:MID select knob-Counterclockwise turn



When the MID select knob is held turned clockwise or counterclockwise for at least 1 second, the nighttime dimmer setting changes from ON to OFF, and vice versa.

Diesel Particulate Defuser (DPD) State

This function displays the amount of particulate matter (PM) accumulated by DPD. During DPD regeneration, the progress of the regeneration is displayed.

Message	Display indication	Color	Display condition
DPD PM accumulation level		Green	The current level of PM accumulation in DPD is displayed.
Progress of DPD regeneration		Amber	The progress of DPD regeneration is displayed until it is completed.







When ERROR is Displayed

→ Refer to page 4-33

DPD PM Accumulation Level

The multi-information display (MID) shows the amount of PM accumulated in the DPD, using a total of six segments.







As the amount of PM in the DPD increases, the number of the displayed segments increases one by one from the left side ("L").

Status	Display	Status	Display
PM level 0		PM level 3	
PM level 1		PM level 4	
PM level 2		PM level 5	

Progress of DPD Regeneration

During DPD regeneration, the MID indicates the progress using a total of six segments. The highest segment flashes.

As regeneration progresses, the number of displayed segments decreases one by one from the right side ("H").

Status	Display	Status	Display
Regeneration progressed to 1st step		Regeneration progressed to 4th step	
Regeneration progressed to 2nd step		Regeneration progressed to 5th step	
Regeneration progressed to 3rd step		Regeneration complete	

Maintenance Data

The maintenance data function indicates the distance remaining before the next scheduled maintenance.

Scheduled maintenance time is approaching when the display turns from green to amber. Have the vehicle checked and serviced at the nearest Isuzu Dealer as soon as possible.



CAUTION

- Your vehicle needs to be maintained more often if it is driven in severe conditions.

Maintenance schedule for severe-condition operations

→ Refer to page 7-162



ADVICE

- The displayed distance represents the interval for each maintenance item before or after the expiration of the scheduled maintenance. When the next scheduled maintenance is approaching, the display background color changes from green to amber to alert you.

Maintenance Message	Display indication	Color	Description	Reference page
Engine oil and filter		Green	Distance remaining until the next engine oil and filter change is displayed.	4-40
		Amber	This is displayed when the next engine oil and filter change is near or has already been reached.	
Transmission oil		Green	Distance remaining until the next transmission oil change is displayed.	4-45
		Amber	This is displayed when the next change of transmission oil is near or has already been reached.	
AMT clutch oil		Green	Distance remaining until the next AMT clutch oil change is displayed.	4-46
		Amber	This is displayed when the next change of AMT clutch oil is near or has already been reached.	
Fuel filter		Green	Distance remaining until the next fuel filter change is displayed.	4-47
		Amber	This is displayed when the next change of fuel filter is near or has already been reached.	
Power steering fluid		Green	Distance remaining until the next power steering fluid change is displayed.	4-48
		Amber	This is displayed when the next change of power steering fluid is near or has already been reached.	
Tyre rotation		Green	Distance remaining until the next tyre rotation is displayed.	4-49
		Amber	This is displayed when the next tyre rotation is near or has already been reached.	



ENG OIL & FILTER
 20000km

How to Set a New Change Interval (Odometer Reading) for Engine Oil and Filter

1. On the MID, go to ENG OIL & FILTER screen.
2. Enter the setting change screen by pressing and holding the MID select knob.



NOTE

- If you want to cancel the setting procedure, press the MID select knob once. The display goes back to the screen that was displayed just before entering the setting change screen.

3. Pressing and holding the MID select knob sets the new change time (distance).



T/MISSION OIL
 45000km



CLUTCH OIL
 40000km



FUEL FILTER
 20000km



P/STEERING FLUID
 40000km

How to Set a New Change Time (Odometer Reading) for Transmission Oil, AMT Clutch Oil (AMT Equipped Model), Fuel Filter and Power Steering Fluid

1. On the MID, go to the screen for the maintenance item for which you want to adjust.
2. Enter the setting change screen by pressing and holding the MID select knob.



NOTE

- If you want to cancel the setting procedure, press the MID select knob once. The display goes back to the screen that was displayed just before entering the setting change screen.

3. Pressing and holding the MID select knob sets the new change interval (distance).



Setting the Tyre Rotation Time (Odometer Reading)

1. On the MID, go to the TIRE ROTATION screen.
2. Enter the setting change screen by pressing and holding the MID select knob.



NOTE

- Your vehicle has been shipped from the factory with no tyre rotation interval set. Therefore, the initial indication on the TIRE ROTATION screen is "OFF" instead of a distance.
- If you want to cancel the setting procedure, press the MID select knob once. The display goes back to the screen that was displayed just before entering the setting change screen.

3. Set the tyre rotation interval by turning the MID select knob.
 - Turn clockwise → Increase distance
 - Turn counterclockwise → Decrease distance
 - The distance increases or decreases by 5,000 km increments.
4. Complete the setting by pressing and holding the MID select knob.

Hour Meter



Hour Meter → Refer to page 4-14

Over Speed



1. On the multi-information display (MID), go to the SPEED WARNING screen.
2. Enter the speed warning setting screen by pressing and holding the MID select knob.



NOTE

- Your vehicle has been shipped from the factory with no warning speed set. Therefore, the initial indication on the SPEED WARNING screen is "OFF".

3. Turn the MID select knob and set the warning speed.

Speed display	Set speed range
km/h	40 to 120 km/h, 10 km/h increments

4. Complete the setting by pressing and holding the MID select knob.

When ERROR is Displayed

If the system has not yet been able to access maintenance data, "ERROR" is shown on the multi-information display (MID).

If "ERROR" does not change automatically to a distance or other maintenance indication, have your vehicle inspected / serviced at the nearest Isuzu Dealer.

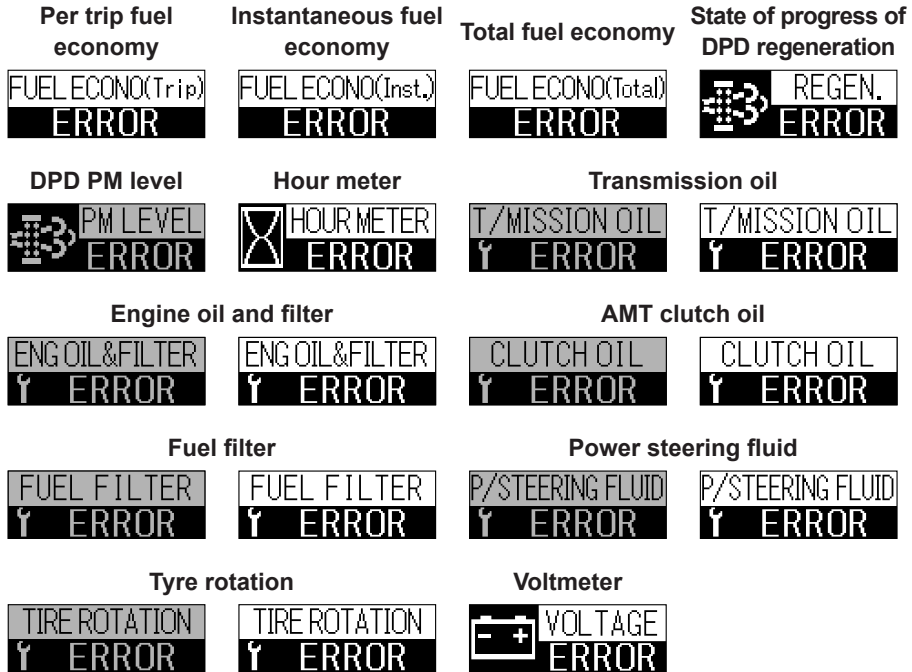

Warning and Indicator Lights

Seat Belt Warning Light



This warning light comes on when the driver is not wearing the seat belt while the starter switch is in the "ON" position.



NOTE

- This warning light goes out as soon as the driver buckles the seat belt.

SRS Airbag Warning Light ▼



The SRS airbag warning light should flash seven times when the starter switch is turned to the "ON" position, and then should go out.

With the SRS airbag warning light on, driver's seat belt with pretensioner and airbag (and passenger's seat belt with pretensioner and airbag, if equipped) may not function properly in the event of a collision.



CAUTION

- If the warning light does not initially flash seven times, does not go out, or comes on while driving, promptly have your vehicle inspected / serviced at the nearest Isuzu Dealer.

Brake System Warning Light

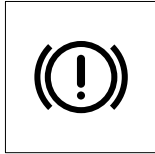

This warning light should come on when the starter switch is turned to the "ON" position, and then should go out after the engine is started.

The brake system warning light comes on while the engine is running (after startup) in the following situations:

- Drop in the level of brake fluid (due to brake wear or fluid leakage, etc.)
- Abnormality in the charging system (such as a generator malfunction or either loosening or splitting of the fan belt, etc.)
- On an anti-lock brake system (ABS) model, abnormality in the ABS (the ABS warning light will also come on.)

ABS Warning Light

→ Refer to page 4-37



CAUTION

- If this warning light comes on while the engine is running, immediately pull off to a safe place well clear of traffic and promptly contact the nearest Isuzu Dealer for inspection.

Brake Booster Warning Light



**BRAKE
BOOSTER**

The warning light and buzzer will come on simultaneously whenever the brake booster's vacuum becomes insufficient either during driving or when the starter switch is in the "ON" position, whenever the hydraulic brake booster (HBB) system becomes faulty, or whenever a problem occurs with the exhaust brake while it is being used. (The warning buzzer will stop sounding when the parking brake is engaged.)

[Vacuum booster models]

The brake booster warning light and warning buzzer alarm should come on to indicate low vacuum reserve for brake power assist.

[HBB models]

When the hydraulic brake booster pressure is low, and/or the hydraulic brake booster fluid (DEXRON® III) level is low, the light and warning buzzer alarm should come on. Do not use brake fluid in the brake booster reservoir. Use only DEXRON® III ATF.

- If this happens while driving:
 - Do not pump the brakes. The system is designed to stop the truck with reserve power assist if the pedal is held down. This reserve is greatly reduced each time you apply and release the brakes.
 - Stopping distance may be longer.
 - You may have to push much harder on the brake pedal. Have the vehicle repaired before you continue driving. The buzzer stops when the parking brake lever on a manual transmission vehicle is pulled up.

**CAUTION**

- If the warning light and warning buzzer come on while the exhaust brake is being used, immediately pull off to a safe place well clear of traffic and take the following actions.
 - With the engine still running, turn off the exhaust brake switch. A problem in the exhaust brake system will be confirmed if the warning light goes out in several seconds.
 - If the warning light does not go out, the problem will be in the brake booster for the foot (main) brake.
Have your vehicle inspected at the nearest Isuzu Dealer as soon as possible.
- This light should come on to provide a bulb check when the engine control switch is turned to the "ON" position. It should go out when the engine has started. If the light does not come on when the engine control switch is turned to "ON", it could indicate a burned out bulb or a blown fuse. Have the system repaired if the light does not come on during this check.

Exhaust Brake Switch

→ Refer to page 4-69

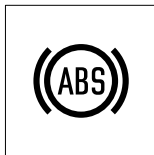
ABS Warning Light 

This warning light should come on when the starter switch is turned to the "ON" position, and then should go out after approximately 2 seconds.

This warning light comes on together with the brake system warning light whenever there is a problem in the anti-lock brake system (ABS). In this case, the ABS stops working but the brakes still function as ordinary service brakes.

**CAUTION**

- If this warning light comes on while driving, immediately pull off to a safe place well clear of traffic and take the following actions.
 - Stop the engine.
 - Restart the engine. Check if the ABS warning light comes on and then goes out. If it does, there is no problem. The ABS operates normally.
- If the indicator light does not go out, or comes on repeatedly, have the vehicle inspected/serviced at the nearest Isuzu Dealer as soon as possible.
- Even if a problem has occurred in the ABS, the brakes will still work as normal brakes. In this case, the ABS has no influence on the operation of the brake system.

Anti-lock Brake System (ABS)

→ Refer to page 4-115

Engine Oil Pressure Warning Light

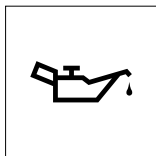

This warning light should come on when the starter switch is turned to the "ON" position, and then should go out after the engine is started.

While the engine is running, this warning light comes on if the engine oil pressure, which lubricates the engine components, is abnormal.

**ADVICE**

- If this warning light comes on while the engine is running, immediately pull off to a safe place well clear of traffic.
- The lubrication system may be faulty. Promptly have your vehicle inspected at the nearest Isuzu Dealer.

Engine Oil → Refer to page 7-22

Over Speed Warning Light

OVER SPEED

Model with Multi-Information Display (MID)

The display will show this warning light when the vehicle speed approaches the speed that was set on the SPEED WARNING screen of the MID.

Engine Overheat Warning Light

Model without MID

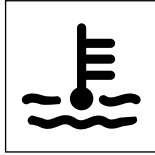

Model with MID



This warning light comes on (a model without multi-information display (MID)) or appears on the display (a model with MID) when the engine has overheated. When the engine overheats, the engine coolant temperature gauge needle reaches the red zone, and the engine overheat warning light comes on (a model without MID) or the message appears on the display (a model with MID), and at the same time a buzzer sounds. Immediately pull off to a safe place, and check the vehicle and take necessary actions.

WARNING

- When the coolant is still hot, do not remove the radiator cap. Hot vapor will come out and you may be scalded. Add coolant only when the coolant temperature has dropped.

Adding the Engine Coolant

→ Refer to page 7-36

CAUTION

- If you continue to drive the vehicle with the engine overheat warning light on steady (a model without MID) or the message appearing on the display (a model with MID), the engine may seize up.

ADVICE

- Do not shut down an overheating engine immediately. Otherwise, the engine may seize up. Take appropriate actions for engine overheating.

When the Engine Overheats

→ Refer to page 8-22

Engine Oil and Filter Indicator Light



(Comes on in amber when the next maintenance interval is near or has already been reached.)

Model with Multi-Information Display (MID)

This message appears on the display when the engine oil and filter maintenance screen is selected or when the next engine oil and filter change interval is near or has already been reached. The distance shown is the remaining distance to the change interval or the distance traveled without replacement after that time.

When the maintenance interval is near or has already been reached, this message appears after the starter switch is turned to the "ON" position. The message remains on the display until the MID select knob is pressed once or the vehicle is started.

When the engine oil and filter indicator light (amber) has come on, have the vehicle inspected / serviced at your Isuzu Dealer.



NOTE

[Checking the engine oil level]

- Check the engine oil level before starting the engine with the vehicle parked on a level surface.
- Check to see if the engine oil and filter indicator light will appear approximately 8 seconds later than the starter switch is turned to the "ON" position.
- When the engine has been running, wait for at least 30 minutes after stopping the engine and then check the oil level.
- Press the MID select knob once or more to display any screen other than the engine oil and filter indicator screen.

Multi-Information Display (MID)

→ Refer to page 4-17

When ERROR is Displayed

→ Refer to page 4-33

Engine Oil

→ Refer to page 7-22

Changing the Engine Oil

and Oil Filter → Refer to page 7-28

Check Engine Oil Level Warning Light **Model with Multi-Information Display (MID)**

This warning light appears on the display when the engine oil level is too low.

**NOTE**

- When the CHECK ENGINE oil level warning light is indicated on the screen, check the engine oil level using the oil dipstick.

Multi-Information Display (MID) 

→ Refer to page 4-17

Engine Oil → Refer to page 7-22

Changing the Engine Oil and Oil Filter → Refer to page 7-28

Air Cleaner Indicator Light **Model with MID**

This indicator light appears on the display when the next air cleaner element cleaning interval is near or has already been reached.

Clean the air cleaner element.

Cleaning the Air Cleaner Element

→ Refer to page 7-52

Changing the Air Cleaner Element

→ Refer to page 7-50

Alternator Warning Light

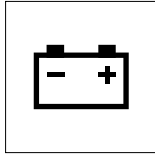

This warning light should come on when the starter switch is turned to the "ON" position, and then should go out after the engine is started.

This warning light comes on when, while the engine is running, there is a problem with the charging system (such as a loose or broken fan belt).



ADVICE

- If this warning light comes on while the engine is running, immediately pull off to a safe place well clear of traffic and promptly contact the nearest Isuzu Dealer for inspection.

Fan Belt → Refer to page 7-44

Handling the Battery

→ Refer to page 7-138

When the Battery Goes Flat

→ Refer to page 8-12

Check Engine Warning Light

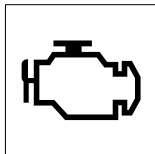

This warning light should come on when the starter switch is turned to the "ON" position, and then should go out after the engine is started.

If this warning light comes on while the engine is running, this alerts you to a problem with the engine electronic control system.



ADVICE

- If this warning light comes on while the engine is running, avoid driving at high speeds and promptly have the vehicle inspected at the nearest Isuzu Dealer.

SVS (Service Vehicle Soon) Indicator Light

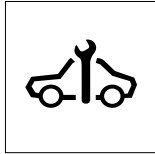

The SVS indicator light will come on when the ignition switch is in the "ON" position and the engine is not started, to let you know the bulb is working.

The indicator light will go off after the engine starts.

If the indicator light comes on during operation, immediately contact the nearest Isuzu dealer for inspection.

Water Separator (Fuel Filter) Warning Light

Model without MID

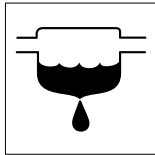

Model with MID



This warning light comes on (a model without multi-information display (MID)) or the message appears on the display (a model with MID) when water in the water separator (fuel filter) needs draining.

Drain water following the instructions in the "Draining Water from the Fuel Filter" and make sure the warning light goes out.

CAUTION

- If this warning light comes on (a model without MID) or appears on the display (a model with MID) while the engine is running, immediately drain water from the fuel filter. If you still continue driving with the warning light on (a model without MID) or with the message on the display (a model with MID), the fuel injection pump may fail.

Draining Water from the Fuel Filter

→ Refer to page 7-58

Bleeding the Fuel System

→ Refer to page 8-15

AMT Warning Light SA

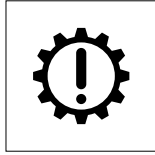

This warning light should remain on for approximately 2 seconds after the starter switch is turned to the "ON" position, and then should go out.

This warning light should flash when the AMT emergency switch is placed in the "ON" position, and should go out when the switch is placed in the "OFF" position.



ADVICE

- If this warning light comes on, have your vehicle inspected as soon as possible at the nearest Isuzu Dealer.
- If this warning light flashes while driving, the AMT oil is abnormally hot. Pull off to a safe place well clear of traffic as soon as possible. Do not start driving again until the warning light goes out.

AMT Warning Light and Warning Buzzer Operation

→ Refer to page 4-91

Transfer LOW Indicator Light V

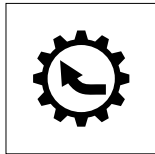

This indicator light comes on when the transfer gear control switch is pressed on the "LOW" side.

Transfer Gear Control Switch V

→ Refer to page 4-127



ADVICE

- Stop the vehicle before operating the switch.

Transmission Oil Indicator Light 

(Comes on in amber when the next maintenance interval is near or has already been reached.)

Model with Multi-Information Display (MID)

This message appears on the display when the transmission oil maintenance screen is selected or when the next maintenance interval for the transmission oil is near or has already been reached. The distance shown is the remaining distance to the oil change interval or the distance the vehicle traveled after passing the maintenance interval.

When the maintenance is near or has already been reached, this message appears after the starter switch is turned to the "ON" position. The message remains on the display until the MID select knob is pressed once or the vehicle is started. When the transmission oil indicator light (amber) has come on, have the vehicle inspected/serviced at your Isuzu Dealer.

Multi-Information Display (MID) 

→ Refer to page 4-17

When ERROR is Displayed

→ Refer to page 4-33

AMT Clutch Oil Indicator Light



(Comes on in amber when the next change interval is near or has already been reached.)

Model with Multi-Information Display (MID)

This message appears on the display when the AMT clutch oil maintenance screen is selected or when the next AMT clutch oil change interval is near or has already been reached. The distance shown is the remaining distance to the oil change time or the distance the vehicle traveled after passing the maintenance interval.

When the maintenance interval is near or has already been reached, this message appears after the starter switch is turned to the "ON" position. The message remains on the display until the MID select knob is pressed once or the vehicle is started.

When the AMT clutch oil indicator light (amber) appears on the display, have the vehicle inspected/serviced at your Isuzu Dealer.

Multi-Information Display (MID)

→ Refer to page 4-17

When ERROR is Displayed

→ Refer to page 4-33

Fuel Filter Indicator Light 

(Comes on in amber when the next change interval is near or has already been reached.)

Model with Multi-Information Display (MID)

This message appears on the display when the fuel filter maintenance screen is selected or when the next fuel filter change interval is near or has already been reached. The distance shown is the remaining distance to the filter change time or the distance the vehicle traveled after passing the maintenance interval.

When the maintenance interval is near or has already been reached, this message appears after the starter switch is turned to the "ON" position. The message remains on the display until the MID select knob is pressed once or the vehicle is started.

When the fuel filter indicator light (amber) has come on, have the vehicle inspected / serviced at your Isuzu Dealer.

Multi-Information Display (MID) 

→ Refer to page 4-17

When ERROR is Displayed

→ Refer to page 4-33

Power Steering Fluid Indicator Light



(Comes on in amber when the next change interval is near or has already been reached.)

Model with Multi-Information Display (MID)

This message appears on the display when the power steering fluid maintenance screen is selected or when the next fluid change time interval is near or has already been reached. The distance shown is the remaining distance to the fluid change time or the distance the vehicle traveled after passing the maintenance interval.

When the maintenance interval is near or has already been reached, this message appears after the starter switch is turned to the "ON" position. The message remains on the display until the MID select knob is pressed once or the vehicle is started.

When the power steering fluid indicator light (amber) is displayed, have the vehicle inspected/serviced at your Isuzu Dealer.

Multi-Information Display (MID)

→ Refer to page 4-17

When ERROR is Displayed

→ Refer to page 4-33

Tyre Rotation Indicator Light 

(Comes on when the next tyre rotation interval is near or has already been reached.)

Model with Multi-Information Display (MID)

This message appears on the display when the tyre rotation maintenance screen is selected or when the next tyre rotation interval is near or has already been reached. The distance shown is the remaining distance to the next tyre rotation time or the distance the vehicle traveled after passing the maintenance interval.

When the maintenance interval is near or has already been reached, this message appears after the starter switch is turned to the "ON" position. The message remains on the display until the MID select knob is pressed once or the vehicle is started.

If the tyre rotation indicator light (amber) has come on, rotate the tyres.

Multi-Information Display (MID) 

→ Refer to page 4-17

When ERROR is Displayed

→ Refer to page 4-33

Tyre Rotation

→ Refer to page 7-86

Low Fuel Warning Light

Model without MID

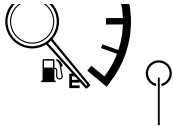

Low fuel warning light

Model with MID



This warning light comes on (a model without multi-information display (MID)) or the message appears on the display (a model with MID) when the fuel level in the tank becomes too low while the engine is running.



ADVICE

- If the low fuel warning light comes on (a model without MID) or the message appears on the display (a model with MID), add fuel at the earliest possible time.
- If the vehicle runs out of fuel, air bleeding procedure must be performed.

Fuel Gauge → Refer to page 4-13
When the Fuel Runs Out
 → Refer to page 8-14

Turn Signal and Hazard Warning Indicator Light

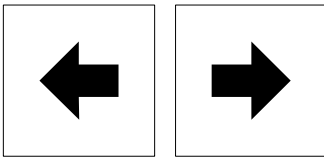

Either of these indicator lights flashes when the turn signal switch is operated with the starter switch in the "ON" position.

Both indicator lights flash when the hazard warning flasher switch is operated irrespective of the position of the starter switch.

Turn Signal Switch → Refer to page 4-65



ADVICE

- These indicator lights will not flash if the bulbs are blown, or may flash abnormally if bulbs of incorrect wattage are used.

High Beam Indicator Light

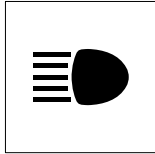

This indicator light comes on when high beam is selected or the headlights are cycled between high and low beams (passing signal).

Light Control Switch

→ Refer to page 4-64

Rear Fog Light Indicator Light

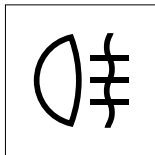

This indicator light stays on while the rear fog lights are on.

Rear Fog Light Switch

→ Refer to page 4-68

Parking Brake Warning Light



This warning light comes on when the parking brake lever is pulled up.



CAUTION

- The illumination of the warning light does not necessarily ensure firm application of the parking brake. The parking brake lever must be sufficiently pulled up and locked.
- Be careful not to drive the vehicle with the parking brake lever still pulled up.

Exhaust Brake Indicator Light

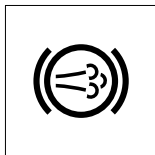

This indicator light comes on when the exhaust brake switch is turned on.



ADVICE

- The exhaust brake indicator light flashes if there is a problem with the exhaust brake system. Have your vehicle inspected at the nearest Isuzu Dealer as soon as possible.

Exhaust Brake Switch

→ Refer to page 4-69

HSA Indicator Light



This indicator light comes on when the hill-start-aid (HSA) system is in operation. The indicator light flashes and a buzzer sounds if you leave your seat while the HSA is in operation, the HSA is used for an extended time period, the vehicle moves when the HSA is engaged or there is a problem with the HSA system.



ADVICE

- If there is a problem with the HSA, disengage the system and have the vehicle inspected at the nearest Isuzu Dealer as soon as possible.

Hill-Start-Aid (HSA)

→ Refer to page 4-98

ASR Indicator Light 

ASR

When the starter switch is turned to the "ON" position, the indicator light should come on and change color from amber to green before it goes out 2 seconds later. This indicator light stays on green while the anti-slip regulator (ASR) is in operation. This indicator light comes on amber if there is a problem with the ASR or when you disengage the ASR using the ASR OFF switch.

**CAUTION**

- If the ASR indicator light comes on amber while driving without operation of the ASR OFF switch, pull off to a safe place well clear of traffic and take the following actions.
 - Stop the engine.
 - Turn the starter switch to the "ON" position. The system is normal if the indicator light comes on first amber and then green before it goes out 2 seconds later. The ASR is operating satisfactorily.
- If the indicator light does not go out, or comes on repeatedly, have the vehicle inspected/serviced at the nearest Isuzu Dealer as soon as possible.

Anti-Slip Regulator (ASR)

→ Refer to page 4-120

Glow Plug Indicator Light

This indicator light comes on when the starter switch is turned to the "ON" position and goes out when preheating is completed. When the indicator light has gone out, the engine may be started.

Starting the Engine → Refer to page 4-4

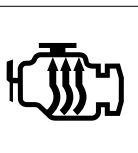
Warm-up System Indicator Light 

This indicator light comes on when the warm-up switch is pressed. While this indicator is on, the engine is warmed up.

Warm-Up Switch

→ Refer to page 4-63

ECONO Mode Indicator Light SA



ECONO

This warning light should remain on for approximately 2 seconds after the starter switch is turned to the "ON" position, and then should go out.

This indicator light comes on when the ECONO mode is selected.

ECONO Mode → Refer to page 4-89

1st Start Mode Indicator Light SA



**1ST
START**

This warning light should remain on for approximately 2 seconds after the starter switch is turned to the "ON" position, and then should go out.

This indicator light comes on when the 1st start mode is selected.

1st Start Mode → Refer to page 4-88

Cruise Control Main Indicator Light V



This indicator light comes on when the cruise control main switch is placed in the "ON" position.

This indicator light comes on when the starter switch is turned to the "ON" position, and then goes out after approximately 5 seconds.

Cruise Control main switch

→ Refer to page 4-108

Cruise Control Set Indicator Light V



This indicator light comes on when the vehicle enters the cruise control mode after the cruise control set switch is operated to set the vehicle speed.

This indicator light comes on when the starter switch is turned to the "ON" position, and then goes out after approximately 5 seconds.

Cruise Control set switch

→ Refer to page 4-109

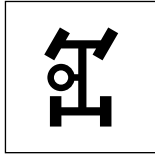
PTO Indicator Light 

This indicator light comes on when the dump control or power take-off (PTO) lever is operated, or when the PTO switch is pressed.

Power Take-Off (PTO)

→ Refer to page 4-128

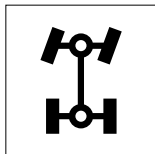
4WD Indicator Light 

The 4WD indicator light comes on on the instrument panel when the 4WD switch is used to select 4WD operation. Whenever you use the 4WD switch, check that this indicator light has come on or gone out as expected before driving.

4WD Switch → Refer to page 4-126

DPD Indicator Light

DPD automatic regeneration indicator light

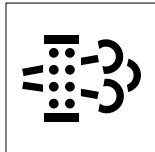

(Green)

DPD manual regeneration indicator light

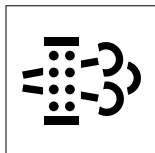

(Amber)

Model without Multi-Information Display (MID)

The DPD automatic regeneration indicator light (green) comes on while the DPD is being automatically regenerated.

This indicator light comes on when the starter switch is turned to the "ON" position, and goes out when the engine is started.

This indicator light comes on when the starter switch is turned to the "ON" position, and goes out when the engine is started.

If the DPD manual regeneration indicator light flashes, manual regeneration (PM combustion) of the DPD needs to be performed.

**CAUTION**

- If your vehicle is a power take-off (PTO)-equipped model and when the PTO is operated for an extended time period, check that the DPD manual regeneration indicator light (amber) is not flashing.
- During extended engine idling, the DPD manual regeneration indicator light (amber) may come on and the DPD may be automatically regenerated.

Diesel Particulate Defuser (DPD)

→ Refer to page 2-60

Diesel Particulate Defuser (DPD)

→ Refer to page 4-154

DPD Manual Regeneration Procedure

→ Refer to page 4-156

Procedure for Selectable Regeneration of DPD

→ Refer to page 4-159

Model with MID

When the "AUTO REGEN." (green) message appears on the display, the DPD is under automatic regeneration.



(Green)



(Amber)



(Amber)



(Amber)

When the "PUSH DPD SWITCH" (amber) message is flashing, the DPD needs to be manually regenerated.

When the "MANUAL REGEN." (amber) message appears on the display, manual regeneration of the DPD is in progress.

Push the DPD switch until the "CHECKING PM LEVEL" (amber) message appears on the display. While the message remains on, the system is checking if selectable regeneration can be performed. If the system determines that selectable regeneration can be performed, the display changes to a flashing "PUSH DPD SWITCH" message.

If the display does not change to "PUSH DPD SWITCH", selectable regeneration does not need to be performed.

**CAUTION**

- If your vehicle is a PTO-equipped model, check that the "PUSH DPD SWITCH" (amber) message is not flashing when you use the PTO for an extended time period.
- During extended engine idling, the "MANUAL REGEN." (amber) message may appear on the MID and the DPD may be automatically regenerated.

Multi-Information Display (MID)

→ Refer to page 4-17

Diesel Particulate Defuser (DPD)

→ Refer to page 2-60

Diesel Particulate Defuser (DPD)

→ Refer to page 4-154

DPD Manual Regeneration Procedure

→ Refer to page 4-156

**Procedure for Selectable Regeneration
of DPD**

→ Refer to page 4-159

Meter Failure **METER****Model with MID**

This message appears on the display when there is a problem with the instrument panel. While the message is displayed, the instrument panel does not function properly.

Pull off to a safe place, stop the engine, and restart it. If the message still appears, contact the nearest Isuzu Dealer.

CAN System Error **CAN****Model with MID**

This message appears on the display when the instrument panel cannot establish normal communications with connected systems.

If a CAN error has occurred, the engine coolant temperature gauge stops functioning and the alarming functions of the panel do not work properly. Pull off to a safe place, stop the engine and restart it. If the message still appears, contact the nearest Isuzu Dealer.

Warning Buzzer

A warning buzzer sounds under the following conditions.

Warning	Buzzer pattern	Location		Condition
		In cab	Outside cab	
Brake booster	Continuous beep	•	×	Refer to page 4-36
Engine overheat	Continuous beep	•	×	Engine has overheated.
Back up <input type="checkbox"/> V	Long, repeated beep	•	•	Gearshift lever is placed in "R" position.
		•	•	
Diesel particulate defuser (DPD) manual regeneration	Short, repeated beep	Three times	×	"PUSH DPD SWITCH" message is flashing. (Model with multi-information display (MID))
	Short beep	One time	×	The DPD manual regeneration indicator light (amber) is flashing. (Model without MID)
Hill-start-aid (HSA) <input type="checkbox"/> V	Refer to page 4-106	*	×	Refer to page 4-106
AMT <input type="checkbox"/> SA	Refer to page 4-91	*	×	Refer to page 4-91

•: Long lasting alarm ×: No alarm

*: Refer to "Condition" column.



ADVICE

- The warning buzzer may not sound if there is a problem with the system. If this occurs, the system needs to be inspected. Please contact the nearest Isuzu Dealer.
- At night, the buzzer back-up warning sound volume can be reduced by placing the light control switch in the "ON" position.



NOTE

- On AMT models, a warning buzzer sounds for approximately 1 second when the starter switch is turned to the "ON" position.

SWITCHES

• Starter Switch	4-60
• Idling Control Knob <input type="checkbox"/>	4-62
• Warm-Up Switch <input type="checkbox"/>	4-63
• Combination Light Control Switch	4-64
• Headlight Leveling Switch <input type="checkbox"/>	4-66
• Front Fog Light Switch <input type="checkbox"/>	4-67
• Rear Fog Light Switch <input type="checkbox"/>	4-68
• Hazard Warning Flasher Switch	4-68
• Exhaust Brake Switch	4-69
• Windshield Wiper and Windshield Washer Switch	4-71
• Horn Button	4-73
• Remote Control Mirror Switch <input type="checkbox"/>	4-73
• Mirror Heater Switch <input type="checkbox"/>	4-74

Starter Switch

WARNING

- While driving, never turn the starter switch to the "LOCK" position. The key could be removed from the switch, which then locks the steering wheel. This is extremely dangerous.

ADVICE

- After starting the engine, do not turn the starter switch to the "START" position. Otherwise, the starter motor may be damaged.
- Using electrical devices such as the audio system for an extended time period with the engine stopped can completely discharge the battery.

Starter Switch

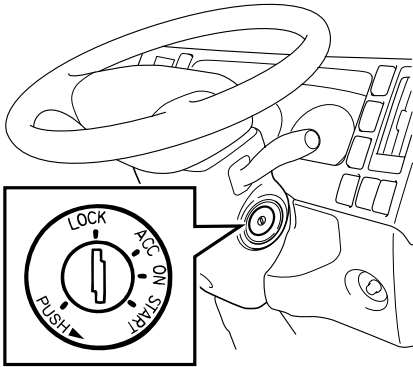

- LOCK** : In this position, the key can be inserted or removed.
Remove the key and turn the steering wheel until it locks. The steering wheel will be locked to help prevent theft. To place the starter switch in the "LOCK" position, press and hold the key in the "ACC" position and then turn it to the "LOCK" position.
- ACC** : In this position, the audio and other accessories can be used with the engine stopped.
- ON** : The key stays in this position while the engine is running. This position is also used for preheating before starting the engine.
- START** : The engine is started in this position. Release the key as soon as the engine has started. The key automatically returns to the "ON" position.



NOTE

- If the key cannot be turned from the "LOCK" position to the "ON" position, lightly move the steering wheel clockwise and counterclockwise while trying to turn the key.

Idling Control Knob V

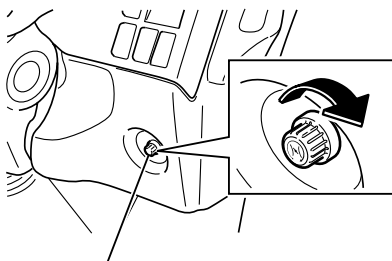

Idling control knob

This knob is used to warm up the engine. You can increase the engine speed by turning the knob clockwise without the need to use the accelerator pedal. Turn the knob back fully counterclockwise after you have used it for engine warm-up and keep it in this position.

WARNING

- Running the engine in a poorly ventilated place can lead to carbon monoxide poisoning. Choose a well ventilated place when starting and warming-up the engine. White smoke may be emitted for a short time during diesel particulate defuser (DPD) regeneration due to combustion of particulate matter (PM). Choose a well ventilated place to perform the manual regeneration.
- If you leave the idling control knob in a high speed position without returning it to the lowest speed position, the vehicle is likely to move suddenly during standing start or it will consume more fuel during subsequent driving or have a shortened clutch life.
Never forget to fully turn the idling control knob back to the lowest speed position before driving the vehicle.

Adjustment angle 300°

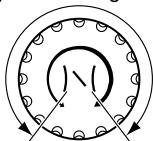

ADVICE

- The idling control knob has an operating range of 300 degrees. Do not try to turn the knob beyond this range. Otherwise, the vehicle may develop a problem.

**NOTE**

- Use the idling control knob to stabilize the engine speed at start when it runs rough.
- Turn the idling control knob fully counterclockwise when the DPD is manually regenerated in order to reduce the engine speed if the knob has been turned clockwise to increase the engine speed.

Starting the Engine

→ Refer to page 4-4

Diesel Particulate Defuser (DPD)

→ Refer to page 4-154

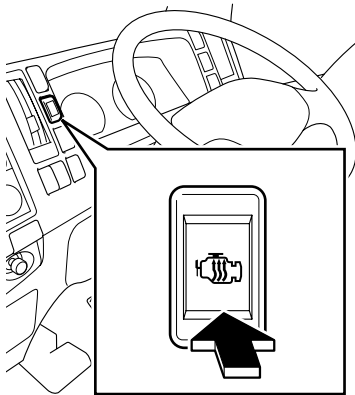
Warm-Up Switch 

This switch is used to allow engine coolant to warm up faster at low temperatures to increase the efficiency of the heater and/or the defroster, or to increase the efficiency of the heater while the vehicle is parked. Start the engine and press the warm-up switch. The warm-up system indicator light on the instrument panel comes on and the engine warms up faster.

After the engine has warmed up, press the switch again to turn the warm-up system to the "OFF" position. The indicator light goes out.

**NOTE**

- The warm-up system does not operate even if the warm-up switch is pressed when it is sufficiently warm, the engine is warm enough or the vehicle is already being driven.
- If your vehicle is equipped with an idling control knob, increasing the engine speed to 1,000 r/min or above using the knob deactivates the warm-up system, in this case the system then does not work even if the warm-up switch is pressed and the warm-up system indicator light comes on.
- If your vehicle is equipped with an anti-lock brake system (ABS), the warm-up system indicator light may go out and the system may disengage even if the warm-up switch is in the "ON" position.

Combination Light Control Switch

Light Control Switch

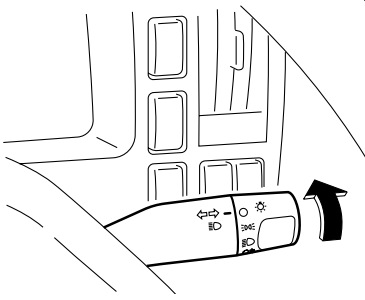

Turning the light control switch to the position indicated in the table causes the relevant lights to illuminate.



ADVICE

- The light control switch can be used when the starter switch is placed in the "LOCK" or "ACC" position. Do not operate the combination lights for an extended time period with the engine stopped. Otherwise, the battery may go dead, making it impossible to restart the engine.

Name	Position			
	○	☰☷	☷☰	☷☷
Headlight	OFF	OFF	ON	ON
Clearance light		ON		
Taillight			ON	
License plate light		ON		
Illumination light control		ON		
Rear fog light <input type="checkbox"/> V	OFF	OFF		

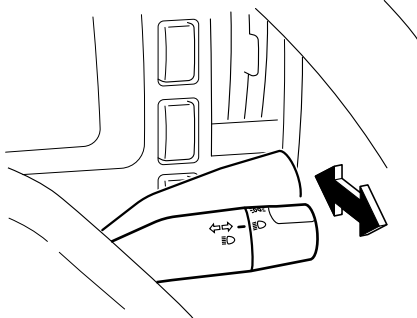

Switching between High Beam and Low Beam

With the headlights on, move the lever forward and backward to switch between the high beam and low beam.

Moving the lever forward selects high beam; moving the lever backward selects low beam.

While the headlights are on high beam, the high beam indicator light on the instrument panel remains on.

**NOTE**

- Use low beam whenever there are vehicles ahead in the same lane or oncoming vehicles in the opposite lane.

When the Bulb Does not Come On

→ Refer to page 8-24

Switching between High and Low Beams (Flash-to-Pass Signal)

By lightly pulling the light control switch lever and releasing it, the high beam comes on and off. At the same time, the high beam indicator light on the instrument panel comes on and off. Use this function as a signal for flash-to-pass a vehicle or other purposes.

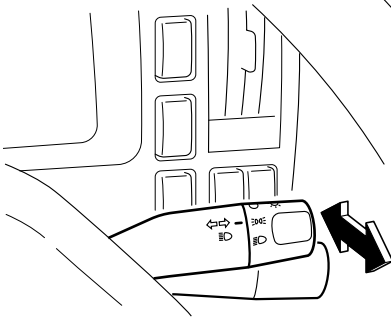
**Turn Signal Switch**

When turning left or right, move the lever up or down to flash the turn signal light.

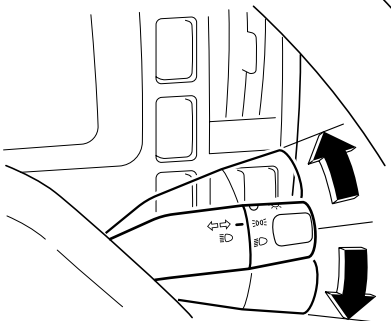
**ADVICE**

- The turn signal lights come on even when the starter switch is in the "LOCK" or "ACC" position. Do not operate the turn signal lights for an extended time period with the engine stopped. Otherwise, the battery may go dead, making it impossible to start the engine.

**NOTE**

- If the steering wheel is only turned a small amount, turn off the signal manually. Lightly press and hold the lever up or down when overtaking or changing lanes. The turn signal light continues flashing as long as the lever is held up or down. The lever moves back to neutral as soon as it is released.

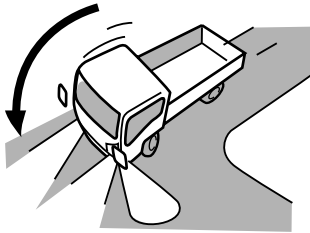
**Cornering Light**

During nighttime, the cornering light illuminates the area to which the vehicle is turning. With the headlights on, the clearance lights come on in coordination with the turn signal lights.

When the Bulb Does not Come On

→ Refer to page 8-24

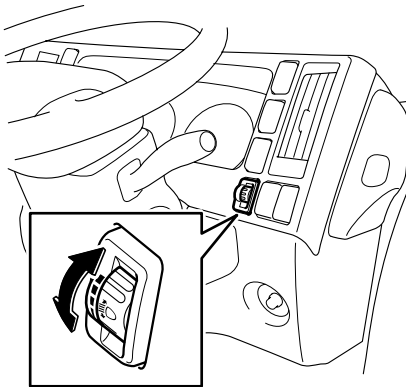
Headlight Leveling Switch **Halogen Headlight Model**

The headlight aim can be adjusted at four different angles. When the cargo load causes the headlights to aim upwards, this feature can be used to lower the aiming angle.

When your vehicle is not loaded with cargo, the switch should be set at the uppermost position. ("0" position)

**CAUTION**

- Do not lower the aiming angle too much. Otherwise, the illuminated range may be so reduced that you may be involved in an accident.

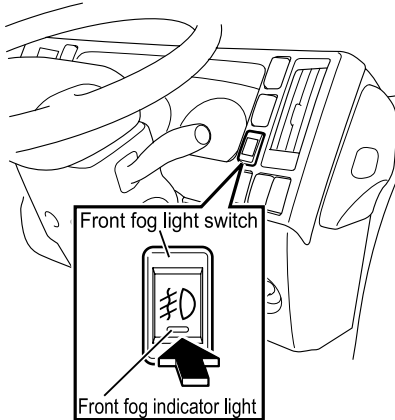
Front Fog Light Switch v**NLR/NNR/NPR/NQR/NPS models**

With the light control switch positioned in ☰ or ☷ , when this switch is pressed, the front fog lights come on and the front fog indicator light comes on. To turn off the lights, press the switch again. The front fog lights are useful when forward visibility is poor such as in fog.

WARNING

- When replacing a front fog light bulb, do not use one of a larger wattage than the specified wattage. Otherwise, the wiring may be burned.

When the Bulb Does not Come On

→ Refer to page 8-24

Rear Fog Light Switch v

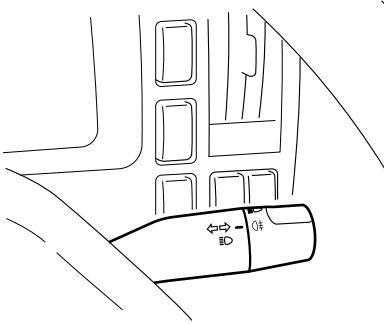

When the light control switch is placed in , the rear fog lights come on and the rear fog indicator light comes on. Use this feature in low visibility such as in fog.

WARNING

- When replacing a rear fog light bulb, do not use one of a wattage larger than the specified wattage. Otherwise, the wiring may be burned.

When the Bulb Does not Come On

→ Refer to page 8-24

Hazard Warning Flasher Switch

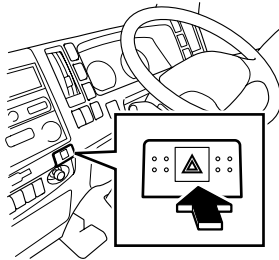

The hazard warning flasher is used to signal other vehicles that your vehicle is stationary on the road because of an accident or component failure.

With the starter switch in any position, when this switch is pressed, all of the turn signal lights and the turn signal indicator lights flash to signal an emergency. To turn off the hazard lights, press the switch again.



ADVICE

- Do not leave the hazard warning flasher operating for an extended time period with the engine stopped. Otherwise, the battery may go dead, making it impossible to restart the engine.

Exhaust Brake Switch

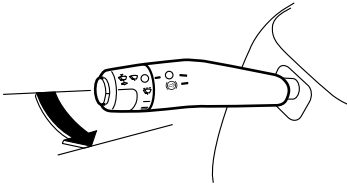

Exhaust brake indicator light

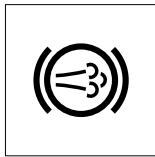

To apply the exhaust brake, pull the lever backward. The exhaust brake indicator light comes on. To disengage the exhaust brake, press the accelerator pedal or the clutch pedal (if your vehicle is a manual transmission vehicle). Releasing the pedal reengages the exhaust brake.

- If your vehicle is equipped with a AMT, the exhaust brake is disengaged during gear shifting or when the engine speed is reduced before the vehicle comes to a stop. The exhaust brake reengages when gear shifting is completed or when the engine speed increases sufficiently.



CAUTION

- It is extremely dangerous to apply the exhaust brake on slippery roads (with their surfaces being wet, frozen, or covered with compacted snow) as the tyres can skid.



ADVICE

- If a warning buzzer sounds when the exhaust brake is in operation, promptly pull the vehicle over safely and contact the nearest Isuzu Dealer for inspection.
- Even if the gearshift lever is placed in the "N" position, the exhaust brake does not disengage until the engine is warmed up if the warm-up system is on.

When you pull the exhaust brake switch toward you while driving, the exhaust brake indicator light on the instrument panel comes on and strong engine brake is applied. Under the following conditions, the exhaust brake does not engage even if the exhaust brake indicator light comes on.

- The accelerator pedal or the clutch pedal (a manual transmission model) is pressed.
- The gearshift lever is in the "N" position.
- The vehicle is traveling at 5 km/h (3 MPH) or lower speeds.
- During gear shifting (an AMT model)

**NOTE**

- If your vehicle is equipped with an anti-lock brake system (ABS), the exhaust brake may disengage during ABS operation even when the exhaust brake switch is in the "ON" position and the exhaust brake indicator light is on. The exhaust brake may disengage temporarily as the vehicle passes over a bump even when the brake pedal is not depressed.

Windshield Wiper and Windshield Washer Switch

To use the windshield wiper and washer switches, the starter switch must be in the "ON" position.

Windshield Wiper Switch

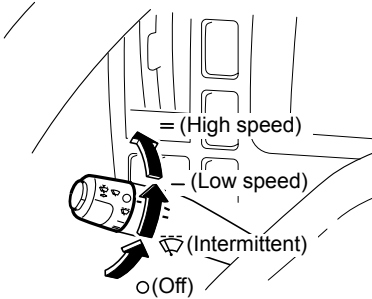

ADVICE

- The safety system may work to stop the wiper when excessive load is applied on the motor. In this case, turn the switch to the "OFF" position and, a few minutes later, check to see if the wiper is back to normal operation. If the wiper frequently stops operation, refrain from using it and contact the nearest Isuzu Dealer.
- Before operating the wiper, ensure that the wiper rubber is not stuck on to the windshield. If the wiper rubber is stuck to the windshield and you still operate the wiper, the wiper may break or the wiper motor may fail.
- Do not operate the wiper on a dry windshield surface. Otherwise, the windshield surface may sustain damage. Always use the windshield washer when wiping a dry glass surface.

The windshield wiper switch has the following positions, which correspond to the states of the wiper.

Lever position	○		—	=
Wiper state	Stopped	<input type="checkbox"/> Intermittent (Light rain)	Low speed (Moderate rain)	High speed (Heavy rain)

Windshield Washer Switch

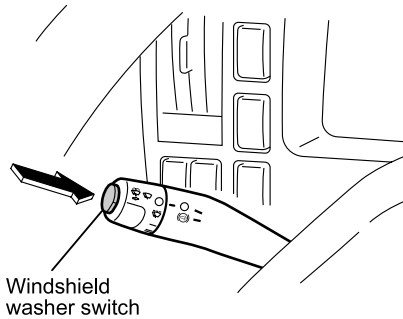

Windshield washer fluid is sprayed over the windshield when this switch is pressed. At the same time, the windshield wiper operates.

The windshield washer is used when wiping the windshield clean.



CAUTION

- At extremely low temperatures, washer fluid may freeze on the windshield after being sprayed, obstructing your forward view. In such a case, warm up the windshield before using the windshield washer.



ADVICE

- If windshield washer fluid does not come out in sufficient quantity, immediately release the switch. Otherwise, the windshield surface may sustain damage.
- Do not hold the switch pressed for more than 30 seconds. Otherwise, the washer pump may sustain damage.
- If windshield washer fluid does not come out, release the windshield washer switch immediately. Otherwise the motor may seize up.
- When the vehicle is used in a cold-climate region, use washer fluid with appropriate concentration for the season to prevent frozen fluid.

Windshield Washer Fluid

→ Refer to page 7-133

Horn Button

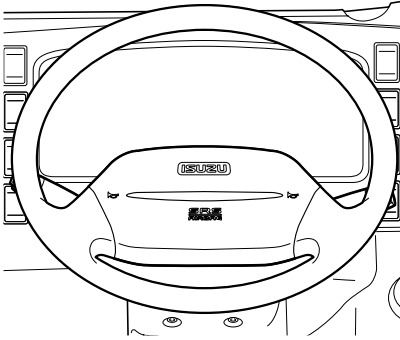

To sound the horn, press the pad with a horn symbol on the steering wheel.

Remote Control Mirror Switch

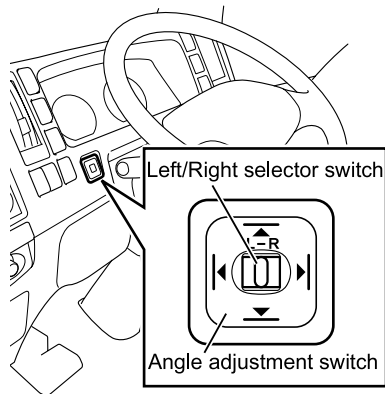

The remote control mirror switch is active only when the starter switch is in the "ACC" or "ON" position.

Adjust

1. Press the left/right selector switch on the "L" or "R" side to move the mirror to the desired direction.
2. Press the angle adjustment switch to adjust the mirror angle.



ADVICE

- Do not try to forcefully move the mirror surface by hand. Otherwise, the mirror motor may sustain damage.

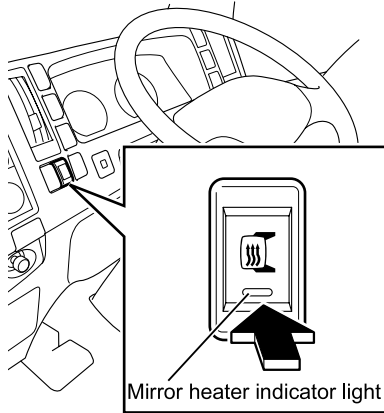
Mirror Heater Switch **Defrosting the Mirror**

Use the mirror heater to defrost the mirror surface. With the starter switch in the "ON" position, press the mirror heater switch to turn on the mirror heater. The mirror heater indicator light (amber) comes on. Press the switch again to turn it to "OFF". The mirror heater indicator light goes out.

**ADVICE**

- Do not use the mirror heater while the engine is not running. The mirror heater consumes a lot of electricity and could discharge the battery completely.
- Turn the switch to "OFF" promptly after the mirror is defrosted.

DRIVING CONTROLS

• Pedals	4-76
• Parking Brake Lever	4-77
• Gear Shift Lever	4-78
• Model with AMT <input type="checkbox"/> SA	4-81
• Hill-Start-Aid (HSA) <input type="checkbox"/> V	4-98
• Cruise Control <input type="checkbox"/> V	4-108
• Hydraulic Brake Booster (HBB) <input type="checkbox"/> V	4-113
• Anti-lock Brake System (ABS) <input type="checkbox"/> V	4-115
• Electronic Braking force Distribution (EBD) <input type="checkbox"/> V	4-119
• Anti-Slip Regulator (ASR) <input type="checkbox"/> V	4-120
• Four Wheel Drive (4WD) Model <input type="checkbox"/> V	4-124
• Power Take-Off (PTO) <input type="checkbox"/> V	4-128
• Seat Belt with Pretensioner and SRS Airbag System <input type="checkbox"/> V	4-143
• Diesel Particulate Defuser (DPD)	4-154

Pedals

M/T model

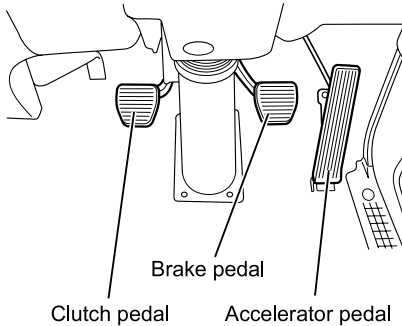

AMT model

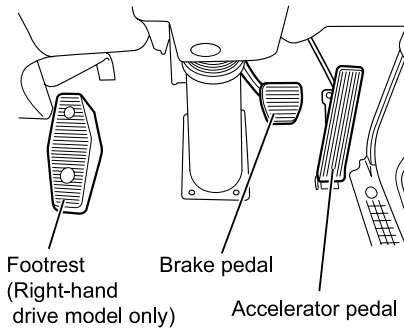

Sit in a correct driving position on the seat and operate the brake pedal and accelerator pedal with your right foot. To avoid accidentally pressing the wrong pedal, check the pedal positions and practice putting your foot on the desired pedal.

WARNING

- A can or bottle rolling on the floor may prevent brake pedal operation if it is caught under the pedal. This is very dangerous. A floor mat must be placed correctly. An incorrectly installed floor mat may hinder the free movement of each pedal.

ADVICE

- Do not race the engine; engine components as well as fuel economy may be badly affected.
- If your vehicle has a manual transmission, do not drive with your foot resting on the clutch pedal. Doing so may damage the clutch.

Parking Brake Lever

CAUTION

- Although the parking brake warning light will come on if the parking brake is engaged while the starter switch is in the "ON" position, this does not mean the parking brake is fully engaged, so always make sure the lever is fully pulled up.
- Simply pressing the release button does not return the lever to its original position. You should always press the release button while pulling the parking brake lever up slightly.
- If the vehicle is parked facing up a hill, place the gearshift lever in the "1 (1st)" gear, and if parked facing down a hill, place the lever in the "R (reverse)" gear. In addition, chocks must always be applied in either of these situations.
- Never park the vehicle on a steep slope.

Operation of Parking Brake

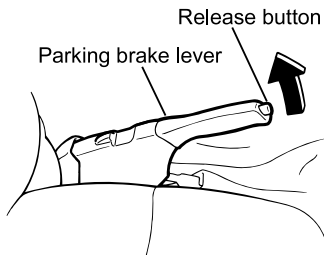

Apply the parking brake lever fully when parking the vehicle. The parking brake warning light in the instrument panel will come on when the lever is pulled up.

To release the parking brake, press the release button while raising the lever a little and then lower the lever. The parking brake warning light in the instrument panel will go out.

Parking brake warning light



Gear Shift Lever

Manual Transmission Model M/T

MY model, 5-speed

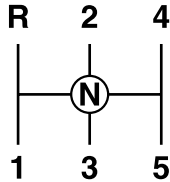

MY or MZ model, 6-speed

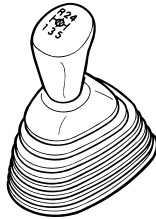
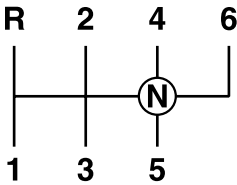

A manual transmission model requires fully depressing the clutch pedal when making a gearshift.

When the gearshift lever is placed into "R (Reverse)", the back up lights come on and, in a model with back up warning, a buzzer will also sound.

**ADVICE**

- Make a shift into the reverse gear from a forward gear or into a forward gear from the reverse gear only when the vehicle has come to a complete stop. Otherwise, the transmission may be damaged.

Model with AMT SA

Move the gearshift lever to make it shift into each gear.

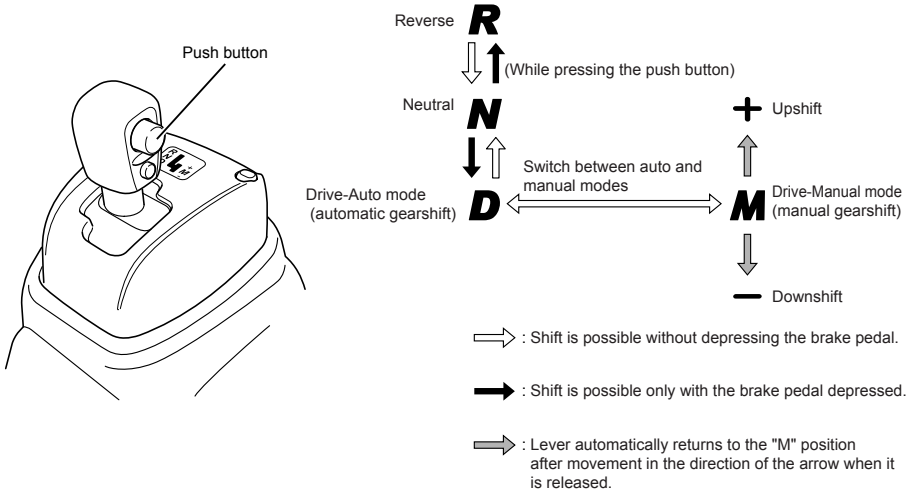

Gearshift lever position	Shift indicator display in instrument panel	Gear position
R	R	Reverse: Used when backing up the vehicle.
N	N	Neutral: Used when starting the engine.
D	^D 1- ^D 5, ^D 6 [6-speed transmission model]	Drive-Auto mode (automatic gearshift): The system automatically selects an optimum gear according to the vehicle speed.
M	+ 1, 2, 3, 4 - 5, 6 [6-speed transmission model]	Drive-Manual mode (manual gearshift): Manually selecting the "+" (upshift) or the "-" (downshift) position allows the driver to select the desired gear.

WARNING

- When operating the gearshift lever while the vehicle is stationary, fully depress the brake pedal until the shift indicator light stops flashing and stays on steady. While the shift indicator light is flashing, the gear is still being shifted and creeping force is not yet available from the AMT. If you release the brake pedal before the indicator light shines steady, the vehicle may move down a slope, possibly causing an accident.

**NOTE**

- While the engine is not running, you cannot shift gears by moving the gearshift lever. Start the engine before you can change the gear.
- When the vehicle is stationary with the engine running, the shift lock function works for safety. You cannot move the gearshift lever from "N" into "D" or "R" without depressing the brake pedal.
When starting the vehicle, be sure to operate the gearshift lever while keeping the brake pedal depressed.

Model with AMT SA

AMT is a transmission system that allows the driver to move the vehicle from a standstill, drive the vehicle with gears automatically changing and bring the vehicle to a stop by only using the gearshift lever, accelerator pedal and brake pedal, without needing to use the clutch pedal. Make sure you fully understand the characteristics of the AMT system and familiarize yourself with its operation.

AMT Model SA

→ Refer to page 2-41

 **WARNING**

- Fully depress the brake pedal to prevent the vehicle from moving even if it is stopped on a level road, and place the gearshift lever into "N" and securely set the parking brake as needed.
- The engine speed is increased immediately after its start, while the air conditioning is in operation or the diesel particulate defuser (DPD) is being regenerated. This makes the transmission produce a stronger creeping force than usual. You need to firmly depress the brake pedal.

 **NOTE**

- If the vehicle is equipped with an idling control knob, the clutch engagement shock may become significant when the engine speed is increased using the idling control knob. Therefore, when placing the gearshift lever into a position other than "N", therefore, turn the idling control knob fully counterclockwise.
- You can utilize the creeping effect of the transmission to move your vehicle smoothly in a traffic jam or in a narrow space by controlling the speed without using the accelerator pedal but by using only the brake pedal.

Idling Control Knob V

→ Refer to page 4-62

How to Use AMT

CAUTION

- Before starting the engine, place the gearshift lever into "N", make sure the shift indicator indicates "N", pull up the parking brake lever and fully depress the brake pedal.
- When moving the gearshift lever from "N" into "D" or "R", be sure to depress the brake pedal.
- Never leave the driver seat with the gearshift lever placed in "D", "M" or "R" while the engine is running. The vehicle may start moving. When leaving the driver seat, be sure to place the gearshift lever into "N" and securely set the parking brake.

To start Your Vehicle - on Normal Roads

1. Fully depress the brake pedal. After making sure the gearshift lever is placed in "N" and the parking brake lever is fully pulled up, place the starter switch into the "ON" position.
2. Start the engine while fully pressing the brake pedal with your right foot. Place the gearshift lever into "D" for forward movement or into "R" for backward movement. The clutch disengages automatically upon operation of the gearshift lever, the gear is changed, and then the clutch is re-engaged automatically. The gear is then controlled in the auto mode (automatic gearshift).
3. Make sure that the shift indicator indicates "D" or "R" at the left upper portion, release the parking brake, release the brake pedal, and then slowly press the accelerator pedal. The vehicle starts moving as you depress the accelerator pedal further.

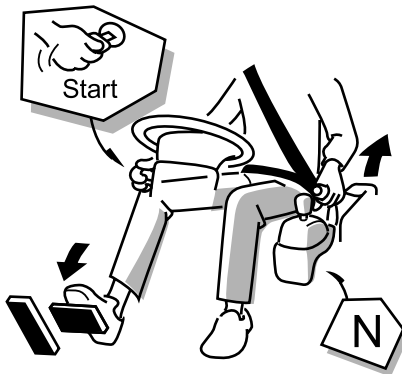

**NOTE**

- When starting the engine after parking with a gear engaged, make sure that the shift indicator indicates "N". Then, place the gearshift lever into "D" for forward movement and "R" for backward movement.
- While the engine is not running, you cannot shift gears by moving the gearshift lever. You must start the engine before you can shift gears.
- When the vehicle is stopped with the engine running, the shift lock function works for safety. You cannot move the gearshift lever from "N" to "D" or "R" without depressing the brake pedal. When starting the vehicle, be sure to operate the gearshift lever while keeping the brake pedal depressed.

To Start Your Vehicle - on a Steep Slope

1. Firmly depress the brake pedal and make sure the parking brake lever is fully pulled up.
2. Place the gearshift lever into the "D" position for forward movement or "R" position for backward movement while fully depressing the brake pedal with your right foot. (When strong traction is required to start the vehicle, change to 1st start mode.)
3. Make sure that the shift indicator indicates "D" or "R" at its left upper portion, check the surrounding area to make sure it is safe to move the vehicle, ease your right foot pressure off the brake pedal, and slowly press the accelerator pedal.
4. After you feel the vehicle start moving, slowly release the parking brake lever and start the vehicle.

**WARNING**

- When you move the gearshift lever to "D" or "R", creep will cause the vehicle to move. When starting the vehicle, be sure to operate the selector lever with the brake pedal depressed.
- When moving a AMT equipped vehicle from a standstill, you must control the speed using only the accelerator pedal. Operate the accelerator pedal carefully.
- Do not operate the gearshift lever while depressing the accelerator pedal. The vehicle may make a sudden start, possibly causing an accident.
- The gear is in the process of being shifted while the shift indicator is flashing. The vehicle may roll down a slope because driving force is not transmitted to the wheels.
Be sure to keep the brake pedal depressed until you see the shift indicator comes on steady.

**ADVICE**

- When the vehicle is stopped, do not keep depressing the accelerator pedal with the gearshift lever placed in the "D", "M" or "R" position while depressing the brake pedal. Doing so may cause a failure.
- When stopping the vehicle on a slope, be sure to fully apply the brakes. Keeping the vehicle stopped by depressing the accelerator pedal to produce a strong creeping effect may cause a failure.

**NOTE**

- The vehicle normally starts off in the 2nd gear. When strong torque is required to start up when the vehicle is heavily loaded, press the 1st start switch to enable the vehicle to start in 1st gear.
- You can also shift into 1st gear when the vehicle is stopped by depressing the brake pedal, placing the gearshift lever into "M" and moving the lever towards "- (downshift)".
- When stopping the vehicle to wait for a traffic light, it is recommended that you place the gearshift lever into "N" for improved fuel economy.

1st Start Mode → Refer to page 4-88

D 1 - ^D5, ^D6

[6-speed transmission model]

To Change Gears - Auto Mode

- When you change the gearshift lever from "N" into "D", shifting takes place in the automatic mode. Check that "D" is displayed on the upper left of the shift indicator.

**NOTE**

- On a continuous steep uphill slope or in a traffic jam, it may be easier for you to drive using the manual mode keeping the vehicle in a particular gear rather than using the auto mode. It is recommended that you drive your vehicle under the above conditions using the manual mode.
- Driving in the ECONO mode can improve fuel economy.

ECONO Mode → Refer to page 4-89

1, 2, 3, 4
5, 6 [6-speed transmission model]

To Shift Gears - Manual Mode

- When changing the gear in the manual mode, place the gearshift lever into the "M" position and move the lever towards the "+" (upshift) or "-" (downshift) direction as necessary to select the desired gear. Check that the desired gear is displayed on the shift indicator.
- The clutch is automatically disengaged upon operation of the gearshift lever. When the shift has completed, the clutch is automatically re-engaged. You can make both upshifts and downshifts in a similar manner.
- Gears are not automatically shifted in the manual mode. To return to the auto mode, place the gearshift lever into the "D" position. Make sure that "D" is displayed on the upper left of the shift indicator.



ADVICE

- Shift into the gear appropriate for the vehicle speed. If an inappropriate gear shift position is selected, a warning buzzer will sound and the shift will not occur.
- Driving using an inappropriate gear in the manual mode will result in a failure of the transmission system. You are alerted to an inappropriate gear selection by a warning buzzer and the transmission is automatically shifted down into an appropriate gear.
- Strongly depressing the accelerator pedal immediately after shifting gears not only prevents the vehicle from running smoothly but also causes a failure of the transmission. Operate the accelerator pedal gradually.

**NOTE**

- When it is necessary to keep the speed of the vehicle very low, as when reversing it onto a platform, you can utilize the creeping effect of the transmission to move the vehicle smoothly using only the brake pedal, not by using the accelerator pedal.

To Stop the Vehicle

1. Press the brake pedal with your right foot to slow down and stop the vehicle. No special gear shifting is required.
After the vehicle has stopped, the gear is automatically shifted into the starting gear in both the manual mode and auto mode.
2. While the vehicle is stopped, place the gearshift lever into the "N" position. When the vehicle must be stationary for several minutes, set the parking brake.

**CAUTION**

- When leaving the driver's seat, be sure to place the gearshift lever into the "N" position, make sure that the shift indicator displays "N" and firmly set the parking brake.

**ADVICE**

- When the vehicle is stopped, do not keep depressing the accelerator pedal with the gearshift lever placed in "D", "M" or "R" while depressing the brake pedal. Doing so may cause a failure.
- When stopping the vehicle on a slope, be sure to fully apply the brakes. Keeping the vehicle stopped by depressing the accelerator pedal to produce a strong creeping effect may cause a failure.

**NOTE**

- When stopping the vehicle to wait for a traffic light, it is recommended that you place the gearshift lever into the "N" position for improved fuel economy.

When Parking Your Vehicle

1. Set the parking brake while depressing the brake pedal with your right foot.
2. Place the gearshift lever into the "N" position, make sure that the shift indicator displays "N", and then slowly ease your right foot off the brake pedal.
3. Stop the engine.

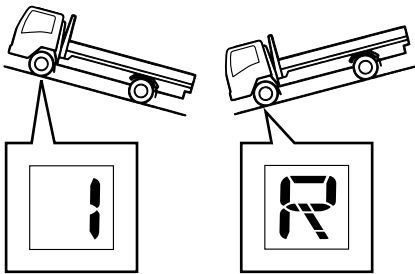

Parking in Gear

When it is necessary to park your vehicle when it is cold outside with the transmission in 1st or reverse gear, follow the steps below.

1. Place the gearshift lever into the "M" position while fully depressing the brake pedal with your right foot, and move the lever towards the "–" (downshift) direction or place the gearshift into the "R (reverse)" position. Make sure the shift indicator displays "1" or "R".
2. Stop the engine and slowly ease your right foot off the brake pedal.
3. Make sure the vehicle does not move. Be sure to block the wheels with chocks.



NOTE

- When starting the engine after parking it with the transmission in gear, first place the gearshift lever into the "N" position and then start the engine with the brake pedal depressed. The shift indicator first displays "1" or "R" but the indication changes to "N" after the engine is started.
After parking the vehicle with the transmission in "R", you will hear a beep when moving the starter switch to the "ON" position. This is normal.
- Make sure that the shift indicator displays "N" when the engine is started after the vehicle has been parked with the transmission in gear before performing the next operation.

1st Start Mode

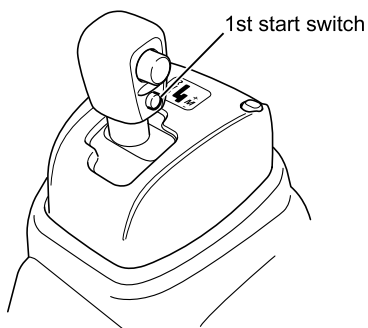

1st start mode indicator light

1ST
START

The vehicle normally moves off from a standstill in second gear. Use the 1st start mode when you need powerful torque to start the vehicle, for example, when it is heavily loaded.

When you press the 1st start switch in auto mode (i.e., when the vehicle is stopped and either the foot brake or parking brake is applied), the 1st start mode indicator light comes on, indicating that the transmission has switched to 1st start mode. Return the transmission to the normal start mode (2nd start mode) by pressing the 1st start switch again.



CAUTION

- The transmission shifts when you press the 1st start switch while the vehicle is stationary. Fully depress the brake pedal before pressing the switch and keep depressing the brake pedal until the shift indicator changes from flashing to steady illumination. While the shift indicator is flashing, the gear is being shifted and the transmission creeping effect does not work. If you release the brake pedal while the indication is still flashing, the vehicle may move down a slope, causing an accident.

**NOTE**

- The 1st start mode cannot be selected in the manual mode.
If the manual mode is selected (the gearshift lever is moved from the "D" position to the "M" position) after the 1st start switch is pressed, the 1st start mode is suspended and the 1st start mode indicator light goes out.
When the mode is changed from the manual mode back to the auto mode (the gearshift lever is moved from the "M" position to the "D" position), the 1st start mode is reestablished and the 1st start mode indicator light comes on again. However the gear position that was selected in the manual mode is still retained. To enable automatic gear shifting to take place, drive the vehicle and then stop it, or press the 1st start switch again to re-select the 1st start mode, or return the transmission to manual mode to make it shift into 1st gear and then change to the auto mode.
- When you place the starter switch in the "LOCK" or "ACC" position and restart the engine, the mode returns to the normal start mode (2nd start mode).

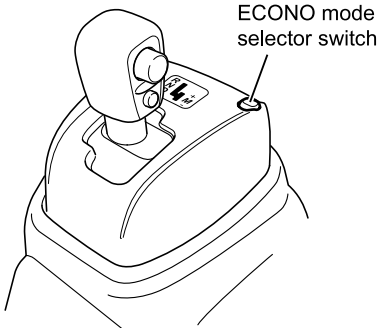
ECONO Mode

You can improve fuel economy if you select the ECONO mode when the vehicle is driven with the transmission in the auto mode (automatic gearshift mode). When you press the ECONO mode selector switch, the ECONO mode is selected and the ECONO mode indicator light comes on.

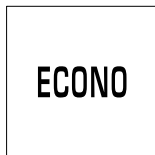
ECONO mode indicator light

**NOTE**

- The ECONO mode cannot be selected while the transmission is in manual mode.
When the transmission is changed to manual mode (the gearshift lever is moved from "D" to "M"), while ECONO mode is active, the ECONO mode indicator light will go out.
When the transmission is changed from manual mode back to auto mode (the gearshift lever is moved from "M" to "D"), the ECONO mode resumes and the ECONO mode indicator light comes on again.
- If the ECONO mode has been selected, it remains active when you restart the engine even if you have turned the starter switch to "LOCK" or "ACC"

AMT Warning Light and Warning Buzzer Operation

The AMT warning light comes on or flashes and the warning buzzer sounds to warn you of the following conditions.

Condition and alarm type	AMT warning light 	Warning buzzer	Corrective action
The driver opens the door and is leaving the vehicle with the starter switch in the "ON" position and the transmission in gear.	—	Short, repeated beeps	Return the gearshift lever to the "N" position and set the parking brake.
The accelerator pedal is kept depressed while the brakes are being applied.	—	Short, repeated beeps	Release the accelerator pedal or return the gearshift lever to the "N" position.
The vehicle is stopped on a slope with the accelerator pedal kept depressed.	—	Short, repeated beeps	Release the accelerator pedal and apply the brakes.
The vehicle continues to be driven in an inappropriate gear. *	—	Short, repeated beeps	Release the accelerator pedal or shift down to an appropriate gear and drive in the manual mode.
The vehicle is started and stopped too frequently.	—	Short, repeated beeps	Stop the vehicle at a safe place, return the gearshift lever to the "N" position and run the engine at idle to cool it down.
The vehicle is driven with the parking brake lever pulled up or the vehicle is stopped by pulling up the parking brake lever with the transmission in gear for a long time.	—	Short, repeated beeps	Release the parking brake. Or return the gearshift lever into the "N" position.
The PTO is being used.	—	Short, slow beeps	—
The AMT system has failed.	Comes on	Continuous beep	Stop the vehicle at a safe place and have your vehicle inspected at the nearest Isuzu Dealer promptly.
		Short, repeated beeps	
		—	

Condition and alarm type	AMT warning light 	Warning buzzer	Corrective action
AMT oil temperature is abnormally high.	Flashes	—	Stop the vehicle at a safe place, place the gearshift lever into the "N" position and run the engine at idle until the AMT warning light goes out.
While in manual mode, the vehicle was driven at low speed in a higher gear. *	—	Short, repeated beeps	Choose a suitable gear when driving in manual mode.
AMT emergency switch is in the "ON" position.	Flashes	—	Turn the AMT emergency switch "OFF".
The AMT adjustment switch was operated.	—	One-time, short beep	—
An attempt is made to shift into a gear that will cause engine r/min to be too high (manual mode).	—	Continuous beep	Place the gearshift lever into the "D" position and drive with an appropriate gear selected. (Automatic gearshifts will not occur.)
An attempt is made to shift into a gear that will cause engine r/min to be too low (manual mode).	—	Short, repeated beeps	Place the gearshift lever into the "D" position and drive with an appropriate gear selected. (Automatic gearshifts will not occur.)

*:The gear is automatically shifted down into an appropriate gear to prevent a failure due to an excessive rise in oil temperature. At the same time, the buzzer sounds to notify the driver that this gear shift has taken place to prevent the oil temperature from rising excessively.

AMT Warning Light SA

→ Refer to page 4-44

How to Adjust Partial Clutch Engagement of AMT

With the AMT system, you can select the desired degree of partial clutch engagement from the 4 positions in both the fast and slow engagement directions from the default (standard) setting. You need to make an adjustment in the following cases.

- If clutch engagement is too fast or too slow when you start the vehicle.
- The timing of clutch engagement does not agree with your preference.

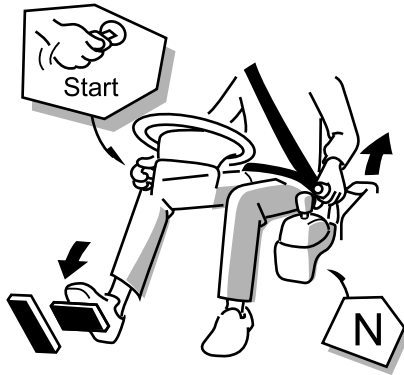

Adjustment

1. With the engine running, pull up the parking brake lever and place the gearshift lever into the "N" position.
2. Press the "FAST" side or "SLOW" side of the AMT adjustment switch. If you feel the clutch slip, press the "FAST" side. If you feel the clutch engages abruptly, push the "SLOW" side. Select your desired position from the 4 plus (+) stages and the 4 minus (-) stages with the centre position as the default. This makes nine stages total.
3. Each time you press the adjustment switch, a buzzer beeps once, showing you that one step of adjustment has completed. If you want to make another step of adjustment, release the switch and press it again. The buzzer beeps again, showing you that the next adjustment has been completed.

Condition	What side of and how many times the switch should be pressed	
	SLOW side	FAST side
Fine adjustment is required.	Once	Once
When you feel the clutch slip.	—	2 to 3 times
When you feel the clutch engage abruptly.	2 to 3 times	—



CAUTION

- If it is not possible to make a full adjustment within the adjustable range (± 4 stages), have the default setting checked at the nearest Isuzu Dealer.
- Make partial clutch engagement adjustments when the engine is running at idle.
- Have the initial adjustment of the AMT system performed at your Isuzu Dealer.

If the AMT System Fails

Should the AMT warning light come on and remain on or flash during driving, stop the vehicle at a safe place. If the warning light does not go out, have the vehicle inspected at your nearest Isuzu Dealer.



CAUTION

- A vehicle with a AMT system cannot pushed to start the engine or to turn the starter motor. If the engine stalls and cannot be restarted, place the gearshift lever into the "N" position and make sure that the shift indicator displays "N". Then push the vehicle to move it to a safe place. If the shift indicator displays any position other than "N", press the AMT emergency switch to the "ON" position and place the gearshift lever into the "N" position. Then push the vehicle to a safe place.

NLR/NNR/NPR/NQR/NPS models

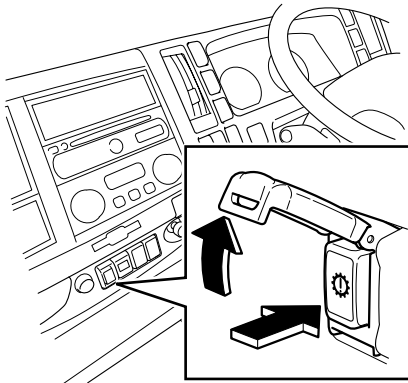

How to Use the AMT Emergency Switch

This switch is used to move the vehicle to a safe place when the AMT electrical system fails.

Normally, the emergency switch must be kept in the "OFF" position. Do not touch it during driving.

Use the following procedure to move the vehicle when the AMT electrical system fails.

AMT Warning Light SA

→ Refer to page 4-44

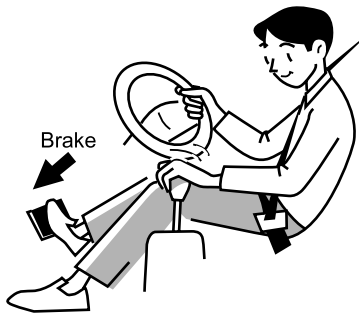

1. Fully pull up the parking brake lever, turn the starter switch to the "LOCK" or "ACC" position while fully pressing the brake pedal and make sure that the gearshift lever is in "N".
2. Turn the starter switch to the "ON" position.
3. Open the cover of the AMT emergency switch, press the switch, and check that the AMT warning light flashes.
4. Start the engine while fully depressing the brake pedal. Release the parking brake and then place the gearshift lever into "D" or "M" for a forward movement or into "R" for a backward movement. Make sure that the shift indicator displays "1" when the gearshift lever is placed in a forward movement position and "R" when the lever is in the backward movement position.
5. Release the brake pedal and slowly depress the accelerator pedal to start the vehicle.

**CAUTION**

- The AMT emergency switch must be used only in an emergency. Normally, the switch must be kept in the "OFF" position. Do not open the cover of the emergency switch. Never operate the AMT emergency switch while driving.
- After you have moved the vehicle to a safe place using the emergency switch, promptly place the emergency switch back to the "OFF" position, return the gearshift lever to "N", and close the cover.
- When the AMT emergency switch is in the "ON" position, the AMT warning light flashes.
- When the emergency switch is in the "ON" position with the gearshift lever in any position other than "N", the vehicle may suddenly start moving. When turning the emergency switch to the "ON" position, be sure to keep the brake pedal depressed.
- When the emergency switch is in the "ON" position, the engine can be started even with the gearshift lever in a position other than "N".
When the engine is started with the transmission in gear, the vehicle may suddenly start moving. To prevent this, firmly set the parking brake and fully depress the brake pedal with your right foot when starting the engine.
- When the emergency switch is placed in the "ON" position, the shift lock function does not work. If you fail to depress the brake pedal when moving the gearshift lever from "N" into "D" or "R", the vehicle will suddenly start moving. Operate the gearshift lever only after holding the brake pedal fully depressed.

**NOTE**

- When the emergency switch is in the "ON" position and the gearshift lever is in the "D" or "M" position, the transmission does not shift to any gear other than the 1st.

Hill-Start-Aid (HSA)

When the HSA is not activated, the service brake system retains a certain level of hydraulic pressure (braking pressure) only while the brake pedal is being depressed. When HSA is activated, the system retains the braking pressure that is produced when the brake pedal is depressed during a stop even after the brake pedal is released. The vehicle is then held stopped for the period of time until the HSA is deactivated. (The HSA works only while the engine is in operation.)

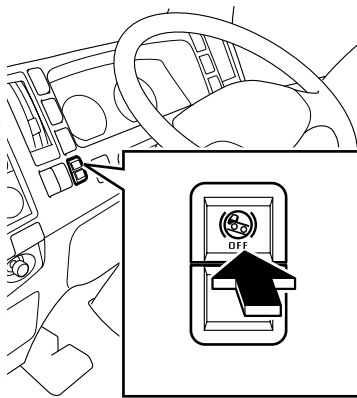
HSA OFF Switch

Press this switch when deactivating the HSA. The HSA stops working.

Pressing the switch again activates the HSA.

**CAUTION**

- Deactivate the HSA on a snowy, icy or otherwise slippery road. When the wheels are locked on a slippery road, the HSA may activate, keeping the wheels locked.

**ADVICE**

- Deactivating the HSA returns the brake system to normal operation. The hydraulic pressure of the brake is not retained when you release the brake pedal.

HSA Adjustment Switch

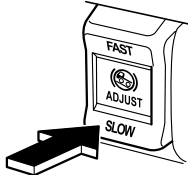
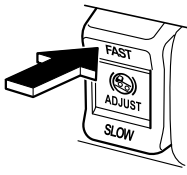
Condition	Switch operation and frequency	
	SLOW side	FAST side
Fine adjustment is required.	 1 to 2 times	 1 to 2 times
Brakes seem to be dragging.	—	2 to 3 times
Vehicle tends to move down on a slope.	2 to 3 times	—
Brakes are dragging.	—	3 to 5 times
Vehicle moves down on a slope.	3 to 5 times	—

 **CAUTION**

- If the brakes cannot be satisfactorily adjusted using the HSA adjustment switch, have the brakes adjusted at the nearest Isuzu Dealer.

How to Use HSA

HSA indicator light

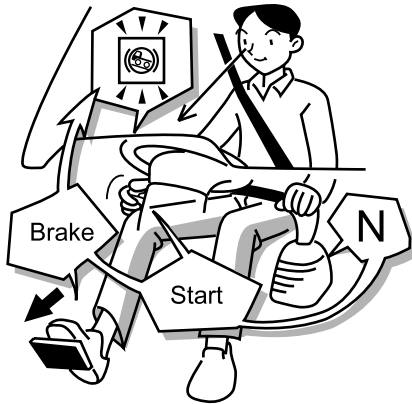
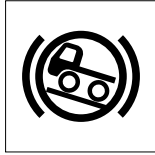

1. Place the starter switch into the "ON" position. Make sure the HSA indicator light in the meter panel comes on and stays on for about 3 seconds.

HSA Indicator Light

→ Refer to page 4-52

2. Start the engine. Release the parking brake and fully depress the brake pedal for at least 1 second. Confirm activation of the HSA by checking that the HSA indicator light in the meter panel comes on. When the HSA OFF switch remains "ON", the HSA indicator light does not come on.

HSA OFF Switch → Refer to page 4-98

3. Pull the parking brake. Confirm deactivation of the HSA by checking that the HSA indicator light in the meter panel goes out.

**CAUTION**

- If the HSA indicator light flashes or remains off or the buzzer continues to sound, the HSA system may have a problem. Deactivate the HSA and have your vehicle inspected at the nearest Isuzu Dealer as soon as possible.

To Activate the HSA

1. Stop the vehicle.

**NOTE**

- The HSA can be activated regardless of the position of the gearshift lever.

2. Fully depress the brake pedal for at least 1 second. At this time the HSA indicator light in the instrument panel comes on, indicating that the HSA is activated.

**CAUTION**

- The HSA is a device to retain the vehicle in a stopped position for a short time and cannot replace the parking brake. When leaving the vehicle, be sure to set the parking brake. If the door should be opened with the HSA activated, a buzzer sounds to alert you.
- If the brake pedal is not pressed down sufficiently when on a steep downslope, the vehicle may move. In such a case, depress the brake pedal down further.
- The HSA is activated about 1 second after the brake pedal is depressed. Keep fully depressing the brake pedal during this period.
- When the vehicle stops after strong braking or due to the wheels locking, the HSA may temporarily not operate. If this happens, use the parking brake or keep depressing the brake pedal to hold the vehicle in place.
- If the HSA system is not working normally, deactivate the HSA and have it inspected at the nearest Isuzu Dealer as soon as possible.

Warning of HSA → Refer to page 4-106



To Deactivate the HSA

The HSA cancels its operation and releases the brakes in any of the following cases.

- When the gearshift lever is placed into a position other than "N" and the clutch is engaged while the engine is running.

Adjustment of HSA

→ Refer to page 4-102

- When the parking brake lever is pulled up.
- When the HSA OFF switch is pressed into the "ON" position.
- When the starter switch is placed into the "ACC" or "LOCK" position.

Adjustment of HSA

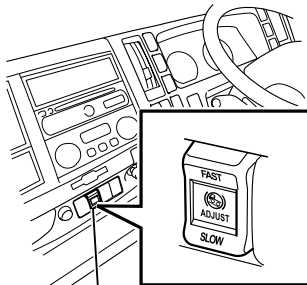

HSA adjustment switch

Make a fine adjustment of HSA in the following cases.

- If the brakes drag when restarting the vehicle.
- When the vehicle moves down a slope when the HSA is activated.
- When the brakes are not released when desired.

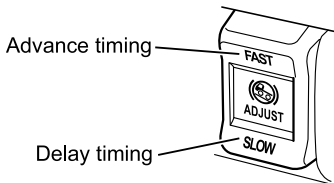
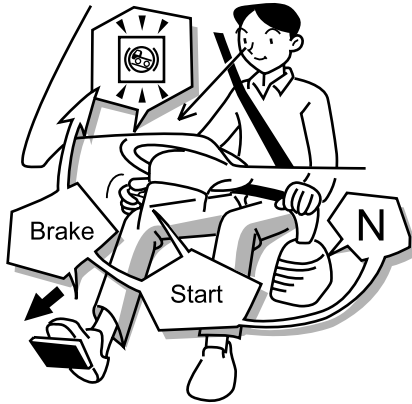

Adjustment

1. Pull the parking brake lever, make sure the gearshift lever is placed in the "N" position and then start the engine. At this time make sure that the HSA OFF switch is placed in "OFF" and that HSA is enabled.
2. Fully depress the brake pedal and release the parking brake lever. Check that the HSA indicator light comes on and then depress the clutch pedal and place the gearshift lever into a position other than "N".
3. If the HSA releases the brakes too slowly and the brakes drag when starting the vehicle, press the "FAST" side of the HSA adjustment switch. If the HSA releases the brakes too early and the vehicle moves down a slope when restarting the vehicle, press the "SLOW" side of the switch. Every time the switch is pressed, a buzzer sounds.
4. Repeat Step 3 above until the brakes are released when desired.

Initial Adjustment of HSA

**ADVICE**

- When a failure warning is issued, the HSA system is faulty. Have your vehicle inspected at the nearest Isuzu Dealer as soon as possible.

Warning of HSA→ Refer to page 4-106

If your vehicle has a manual transmission, make an initial adjustment of the HSA in the following cases. No initial adjustment is necessary for a AMT equipped model.

- The clutch is replaced or play of the clutch pedal is adjusted.
- The HSA releases the brakes much too slowly or much too quickly when the vehicle is started.
- The control unit of the HSA is replaced.

Adjustment

1. Pull the parking brake lever, make sure the gearshift lever is placed in the "N" position and then start the engine.
2. Depress the clutch pedal, place the gearshift lever into the "2 (2nd)" position and press the HSA reset switch. A buzzer makes two short beeps repeatedly and the HSA indicator light flashes.
3. Slowly release the clutch pedal and when the engine speed drops 30 to 50 r/min from the idle speed, press either the "FAST" side or "SLOW" side of the HSA adjustment switch. The buzzer then stops sounding.
4. Depress the clutch pedal, place the gearshift lever into the "N" position and slowly release the clutch pedal.

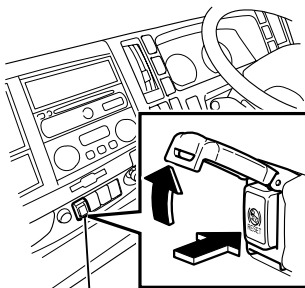

HSA reset switch

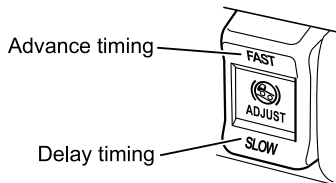

5. Depress the clutch pedal, place the gearshift lever into any other position than "N", start the vehicle, and then make a fine adjustment using the HSA adjustment switch so that the brakes are released at the appropriate time.

**ADVICE**

- Perform the series of operations while the parking brake is firmly set.
- After placing the gearshift lever into the "N" position, slowly release the clutch pedal.
- Be sure to make an adjustment of the HSA after adjusting clutch pedal play.

Warning of HSA

The HSA indicator light comes on or flashes and a buzzer sounds to give a warning in the following cases.

Condition and alarm type	HSA indicator light	Buzzer	Corrective action
A door is opened without pulling the parking brake while the HSA is activated.	Flashes	Short, repeated beeps	Pull up the parking brake lever before opening the door.
Too long activation warning. The vehicle is stopped a long time with the HSA activated.	Flashes	Short, repeated beeps	Use the parking brake for stopping or further depress the brake pedal.
Vehicle movement warning. The vehicle starts moving during a stop using the HSA.	Flashes	One-time beep	
Failure warning. The HSA indicator light and buzzer are activated.	Flashes	Short, repeated beeps	Stop the vehicle safely and deactivate the HSA using the HSA OFF switch.
	Flashes	—	
	On	Beep (continuous)	
Starter switch "LOCK" or "ACC" warning. The starter switch is placed into the "LOCK" or "ACC" position without pulling the parking brake.	Off	Short, repeated beeps (lasts up to 30 seconds)	Pull the parking brake lever.



CAUTION

- When a failure warning is issued, the HSA system is faulty. Have your vehicle inspected at the nearest Isuzu Dealer as soon as possible.



NOTE

- A buzzer sounds when you open the door without pulling the parking brake lever with HSA activated.
- When you park the vehicle in gear without pulling the parking brake lever in order to park in cold regions, a buzzer will sound for about 30 seconds. This does not indicate any abnormal condition.

Parking in Cold Regions

→ Refer to page 6-15

**CAUTION**

- When leaving the driver's seat, be sure to firmly set the parking brake.
- Since the HSA no longer provides braking pressure if the starter switch is turned to the "ACC" or the "LOCK" position, the HSA OFF switch is pressed, or the fuse for the HSA circuit is removed while the HSA is activated, the vehicle will move down a slope and a very dangerous situation may result.
- If the vehicle rolls while the HSA is activated, either push the brake pedal further down or ensure that the parking brake is fully applied.
- Use the parking brake when stopping the vehicle with a gradient of 10% or higher if the vehicle is loaded up to the rating limit.
- When stopping the vehicle for a long time, set the parking brake rather than relying on the HSA.
- If you suspect a problem with the HSA, press the HSA OFF switch to turn it off. Normal braking will be restored.
- When the parking brake lever is pulled up while the HSA is activated, the HSA is automatically cancelled.
- Even while the HSA stays activated, the stop lights go out when you release the brake pedal.
- The HSA works only while the engine is in operation.
- When the vehicle stops after strong braking or due to the wheels being locked, the HSA may temporarily not operate. If this happens, use the parking brake or keep depressing the brake pedal to hold the vehicle in place.

Cruise Control

The cruise control function allows you to drive the vehicle at a constant speed without operating the accelerator pedal. The setting range for cruise control is approximately between 40 and 80 km/h (25 and 50 MPH). This function should only be used when driving without frequent starts and stops.

WARNING

Do not use the cruise control function on the following roads, where using it could be dangerous.

- A road with a heavy traffic, such as an urban road
- A road that includes sharp curves and steep downhill slopes
- An icy, snowy or otherwise slippery road

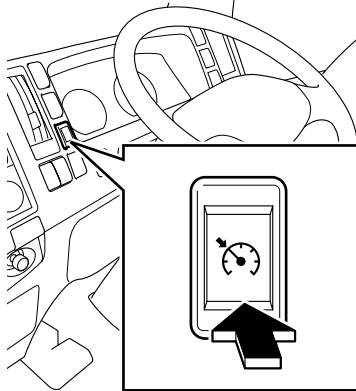
Setting to Your Desired Vehicle Speed**Cruise control main switch**

1. Press the cruise control main switch to the "ON" position. The cruise control main indicator light will come on.

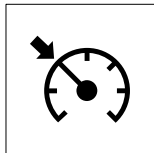
Cruise control main indicator light

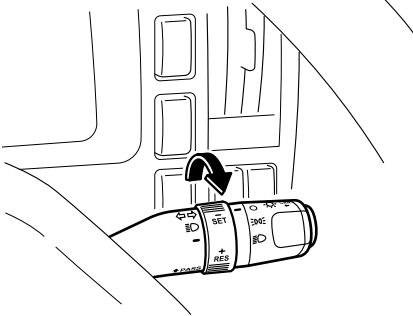
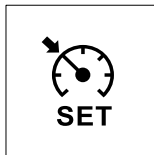
Cruise control set switch**Cruise control set indicator light**

2. Use the accelerator pedal to adjust the vehicle to a desired speed between approximately 40 and 80 km/h (25 and 50 MPH). Upon reaching the desired speed, operate the cruise control set switch. The vehicle speed at the moment you operate the switch is set in the system, enabling you to drive with the set speed automatically maintained without using the accelerator pedal. At the same time the cruise control set indicator light comes on.

**NOTE**

- When you use the exhaust brake, the cruise control cannot be set. Turn off the exhaust brake switch.

Exhaust Brake Switch

→ Refer to page 4-69

Accelerating during Cruise Control Driving

If you want to accelerate temporarily to pass another vehicle while driving using the cruise control, depress the accelerator pedal. When you release the accelerator pedal, the speed returns to the original set vehicle speed.

Changing the Cruise Control Speed Setting

Cruise control resume switch

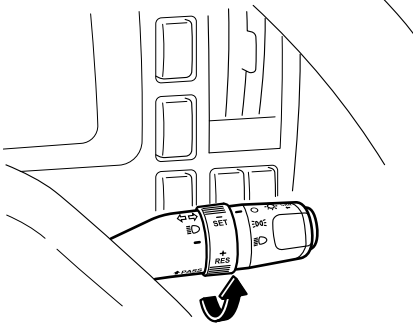

When Increasing Vehicle Speed

When the cruise control resume switch is operated, the speed increases while the switch is held.

After the speed is increased to the desired vehicle speed, and the switch is released, the speed is set at the increased vehicle speed. If you want to increase the speed quickly, depress the accelerator pedal and accelerate to the desired vehicle speed. Then, operate the cruise control set switch.

When Increasing Vehicle Speed Slightly

If the cruise control resume switch is operated and released immediately, the set vehicle speed increases 1 km/h (0.6 MPH) per operation.

Cruise control set switch

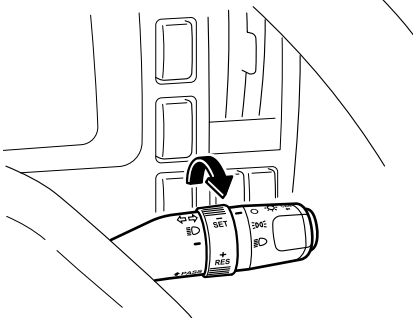

When Decreasing Vehicle Speed

When the cruise control set switch is operated, the speed decreases while the switch is held.

After the speed is decreased to the desired vehicle speed, and the switch is released, the speed is set at the decreased vehicle speed. If you want to decrease the speed quickly, depress the brake pedal to cancel cruise control and decelerate to the desired vehicle speed. Then, operate the cruise control set switch.

When Decreasing Vehicle Speed Slightly

If the cruise control set switch is operated and released immediately, the set vehicle speed decreases 1 km/h (0.6 MPH) per operation.

When Canceling Cruise Control

Cruise control main switch

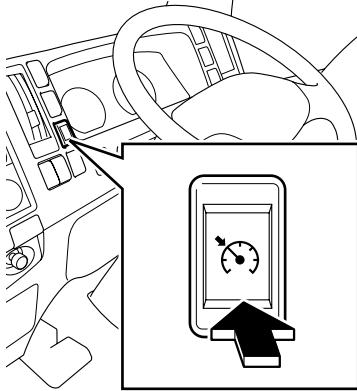

Press the cruise control main switch again to set it to "OFF". The cruise control main indicator light will go out.

The cruise control is canceled in the following cases.

- When the brake pedal is depressed.
- When depressing the clutch pedal (manual transmission model).
- When applying the exhaust brake.
- When the vehicle speed decreases to approx. 40 km/h (25 MPH) or less.
- When there is an abnormality in the engine control system.
- When the vehicle speed decreases approx. 40 km/h (25 MPH) or more from the set vehicle speed.
- When shifting gears.
- When operating the cruise control cancel switch.

Cruise control cancel switch

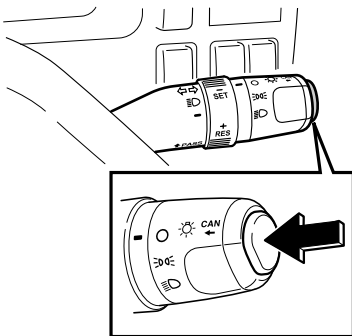

ADVICE

- When you do not use the cruise control, be sure to place the cruise control main switch into "OFF".
- When you place the starter switch into "ACC", place the cruise control main switch into "OFF" then reset the cruise control.



NOTE

- A AMT model may automatically shift during the auto mode operation. This does not cancel cruise control.

When Returning to Cruise Control Driving

If you have canceled cruise control under the following conditions, you can return to the cruise control driving condition before cancellation when you operate and release the cruise control resume switch. The moment the resume switch is released, the cruise control set indicator light comes on.

- When depressing the brake pedal.
- When applying the exhaust brake.
- When shifting gears.
- When operating the cruise control cancel switch.

Auxiliary Brake Function

Automatic activation of the auxiliary brake (exhaust brake) during cruise control driving suppresses an increase in the speed on a downhill slope, decreasing the need for the driver to apply the regular brake pedal.



CAUTION

- The maximum slope angle at which the system can control the vehicle speed increase is different depending on the load the vehicle is carrying.

Automatic Activation and Automatic Release of Auxiliary Brake

- The auxiliary brake is engaged when the vehicle speed exceeds the set speed on a downhill slope.
- The auxiliary brake is disengaged when the vehicle slows down close to the set speed.

Hydraulic Brake Booster (HBB) 

HBB is a brake booster device that utilizes hydraulic pressure from the HBB pump integral with the power steering pump.

**CAUTION**

- If the brake booster warning light comes on or a warning buzzer continues to sound, there may be a problem with the HBB.
If this warning light comes on while driving, immediately pull off to a safe place well clear of traffic and promptly contact the nearest Isuzu Dealer for inspection.

Brake Booster Warning Light

→ Refer to page 4-36

**NOTE****[HYDRAULIC BRAKE BOOSTER CHARACTERISTICS]**

In the HBB models, an unusual sound from under the instrument panel may be heard from the hydraulic system while brakes are used. It does not mean trouble. It is not a sign of malfunction.

- If you pump the brakes with the engine off, a squeaking sound can be heard. This comes from the auxiliary accumulator. It is not a malfunction. With the engine running, a similar sound can be heard during sudden braking.
- Another characteristic of the HBB system is that the brake pedal may be depressed easily to the floor with the vehicle at a stop. This is not a sign of malfunction.
- When the engine is running, the system automatically charges the accumulator whenever pressure has been reduced after braking. Auto charge may be activated without braking, depending on temperature changes in the accumulator. During auto charge, a hissing and clicking sound can be heard. This is not a malfunction.
- With the engine running, a booming sound can be heard during hard braking. This comes from the brake-fluid pump. It is not a malfunction.

Applying continuous hard braking for a long time will lead to considerable temperature rise in the hydraulic booster pump. Such overworking of the brakes is best avoided.

[VACUUM OR HYDRAULIC POWER ASSISTED BRAKES]

If the engine stops, do not pump the brakes. The system is designed to stop the vehicle with reserve power assist if the brake pedal is held down. This reserve is greatly reduced each time you apply and release the brakes. If, when you turn the steering wheel during braking, the vehicle does not turn, release some pressure from the brake pedal.

Without power assist the vehicle can still be stopped by pushing much harder on the brake pedal, however, the stopping distance may be longer.

Anti-lock Brake System (ABS) V

Wheels may be locked and slip during sudden braking or braking on a slippery road surface such as a snowy road. ABS is a device to prevent the wheels from by detecting a slippery condition during braking and to secure directional stability and handling stability of the vehicle. ABS is only to assist in slippery conditions and will not prevent an accident if you exceed safe driving speeds for road conditions. Always drive safely.

**CAUTION**

- The braking distance on slippery road surfaces is longer than that on a normal dry paved road even with an ABS-equipped vehicle. In addition the braking distance can be slightly longer in deep snow and on a gravel road when ABS is activated. Therefore, always keep in mind the road condition and tyre condition (type of tyres and worn condition), observe safe driving habits and drive the vehicle while keeping a proper distance between vehicles.
- ABS does not prevent accidents if you do not drive safely. Drive the vehicle at a safe speed.
- Install tyres of the specified size, same brand and same tread design (including winter tyres) on all wheels. If different tyres are installed, the braking distance becomes longer and directional control stability of the vehicle decreases. This is very dangerous.
- Steering during sudden braking (when the ABS is working) will feel slightly different than it does when the brakes are not applied. Operate the steering wheel carefully keeping this in mind.

**ADVICE**

- Driving in sand or on a muddy road may adversely affect the brakes and ABS sensors. Wash the vehicle to remove sand and mud after operating the vehicle in sandy or muddy conditions.
- Before washing the vehicle, provide necessary protection to prevent water from being splashed on the ABS components (sensors and actuators). Especially when using high-pressure washing, be careful not to allow water to be directly sprayed onto the ABS components and their harness connectors.

**NOTE**

[These are not signs of ABS malfunction]

- Immediately after the engine is started, a motor sound may be heard from the rear of the vehicle or from the underside of the cab. This sound is from a self-check by the ABS. In addition, you may also feel some vibration if the brake pedal is pressed at this time.
- When ABS is operating, vibration is felt on the brake pedal and steering wheel and you may hear the system operating. This is normal when ABS is properly operating.
- When ABS is activated while the exhaust brake is in operation, the exhaust brake may release.
- ABS is more likely to be activated when the brake is applied during cornering or driving over a bump. This is because inside wheels or wheels that have gone over a bump tend to lock.
- ABS is not activated immediately after starting the vehicle. It is activated only when the vehicle speed reaches approx. 10 km/h (6 MPH). ABS operation is inactive when the vehicle speed reduces to approx. 5 km/h (3 MPH).

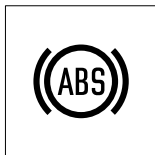
ABS Operation Indications and Signs**ABS warning light****Operation Indications of ABS**

When the starter switch is placed into the "ON" position, the ABS warning light comes on and then goes out in approx. 2 seconds. The ABS is normal if the warning light goes out.

Operation Signs of ABS

When ABS is activated, slight vibration is generated on the brake pedal and steering wheel, and an operating sound can be heard from the ABS equipment.

**NOTE**

- If the ABS warning light does any of the following, the ABS may be faulty. Please contact the nearest Isuzu Dealer.
 - If the ABS warning light comes on during driving
 - The light does not come on when the starter switch is placed into the "ON" position
- Even if a problem has occurred with the ABS, the regular brakes will still work normally. However, ABS will not operate.

ABS Warning Light 

→ Refer to page 4-37

Precautions for Driving an ABS-Equipped Vehicle

ABS is not a device that enables driving and stopping under conditions exceeding safe driving limits. Always drive safely.



CAUTION

- The braking distance on slippery road surfaces is longer than that on a normal dry paved road even with an ABS-equipped vehicle. When ABS is activated in the following road surface conditions, the braking distance may be slightly longer compared to that of vehicles not equipped with an ABS. Therefore, always be aware of the road and tyre condition (tyre type and wear condition), observe safe driving habits and drive the vehicle while keeping a safe following distance.
 - When driving on a gravel road, or a road with a deep snow covering.
 - When tyre chains are used.
 - When driving over road joints or bumps such as light reflectors on the road.
 - When driving on a bumpy road, stone-paved road or track.
 - When driving over an iron plate or manhole lid.
- ABS does not work for wheel skid during a standing start, acceleration and cornering which do not involve braking. On a very slippery icy road, tyres may lose grip and steering wheel operation may not be able to control the vehicle's direction, resulting in very unstable driving. Always drive the vehicle observing a safe speed well matched with both road surface and tyre conditions, and avoid sudden braking.
- If powerful engine braking is applied on a very slippery icy road, the drive wheels may be locked (the ABS then does not work), resulting in loss of vehicle control. If this happens with a manual transmission vehicle, disengage the clutch or place the gearshift lever into the "N" position to prevent engine braking from acting on the drive wheels. Then, drive the vehicle with the gearshift lever placed in an appropriate gear.
- When ABS is activated, a slight vibration (especially when the road surface is different between right and left wheels) and pulling may be felt on the brake pedal and steering wheel. In addition, an operating sound is produced from the ABS actuators. This does not indicate any abnormal condition. Stay calm and operate the steering wheel properly.

Electronic Braking force Distribution (EBD)

EBD is a function that uses the ABS to distribute braking force ideally between the front and rear wheels in order to compensate for changes in load conditions or any shift of the load due to acceleration or deceleration, thus preventing premature locking of the rear wheels.

**CAUTION**

- If a problem should occur with the EBD function, the ABS warning light and the brake warning light will come on simultaneously.
- The rear wheels will lock more easily if there is a problem with the EBD function. Have it checked and serviced at the nearest Isuzu Dealer as soon as possible.

**NOTE**

- When the EBD operates, the brake pedal may push back slightly or you may hear a sound similar to that generated by the ABS when operational. Neither of them indicate any abnormal condition.

Anti-Slip Regulator (ASR) 

ASR is a device that helps prevent the drive wheels from spinning and improve vehicle motion stability when driving on a snowy or otherwise slippery road surface. The ASR is automatically activated when the engine is started. You may cancel the ASR operation using the ASR OFF switch.

**CAUTION**

- When ASR is activated, the ASR indicator light (green) comes on. The road surface at this time is very slippery. If the indicator light comes on, drive carefully and reduce the speed sufficiently before negotiating a curve.
- Even with the ASR-equipped model, when driving on a snowy or icy road, carefully drive the vehicle, installing tyre chains or winter tyres.
- ASR is not a device to drastically improve the vehicle starting performance. Carefully operate the accelerator pedal when moving on an icy slope.
- When tyre chains are installed, it may be easier for you to start the vehicle to move on an icy slope if the ASR is canceled. Be aware, however, that ASR deactivation will result in reduced stability of vehicle operation.

**ADVICE**

[These are not signs of ASR malfunction]

- The engine speed may suddenly decrease, but this is because the ASR device is operating.

**NOTE**

- When using a speed tester or brake tester, press the ASR OFF switch to cancel the ASR device.

ASR OFF Switch

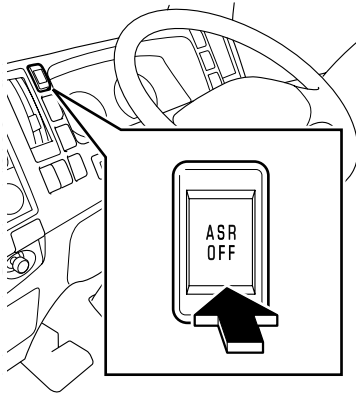

ASR indicator light



(Amber)

Use this switch when you want to cancel the ASR. When you press this switch while the ASR is active after starting the engine, the ASR is cancelled and the ASR indicator light (amber) in the instrument panel comes on. When the switch is pressed again, the ASR function turns back on.

**ADVICE**

- When you turn off ASR, it will not be available to assist you in slippery driving conditions. Always use caution when driving on slippery roads.
- Be sure to enable ASR during normal driving.

**NOTE**

- If ASR is OFF when the engine is turned off, it is automatically re-enabled when you restart the engine.

ASR Operation Check and ASR Operation**ASR indicator light****(Green/Amber)****ASR Operation Check**

When the starter switch is turned to the "ON" position, the ASR indicator light comes on amber and then turns green before it goes out in about 2 seconds. ASR is normal if the indicator light goes out.

When ASR is Operational

When ASR is operating, the ASR indicator light (green) comes on. When the ASR OFF switch is pressed, the ASR indicator light (amber) comes on.

**NOTE**

- If the ASR indicator light does any of the following, ASR may be faulty. Please contact the nearest Isuzu Dealer.
 - When the ASR indicator light (green) remains on while driving on a firm, dry road.
 - When the ASR indicator light (amber) comes on during driving (when the ASR OFF switch is not operated).
 - The ASR indicator light does not come on when the starter switch is turned to the "ON" position.
- If the ASR is faulty, it does not interfere with normal driving. However, the ASR will not function.

ASR Indicator Light → **Refer to page 4-53**

Precautions for Driving an ASR-equipped Vehicle

ASR is not a device that enables driving under conditions exceeding safe limits. Always drive safely.



CAUTION

- The ASR does not increase the road grip of tyres although it improves the starting and accelerating performance on a slippery road surface when compared to a model without ASR. On an icy or otherwise slippery road, the grip of tyres decreases which also reduces steering control, resulting in unstable vehicle behavior. Always drive the vehicle observing a safe speed well matched to the road surface and tyre conditions, and also avoid speeding.
- Even if ASR is equipped, avoid sudden operation of the accelerator pedal, clutch pedal (manual transmission model) and steering wheel. Especially when starting the vehicle on a slippery road, start up slowly as you would in a vehicle without ASR.



NOTE

- When you drive up a slippery, long slope by increasing the engine speed, where the tyres may slip, or when you want to dislodge the vehicle from a deep snowy road or mud, you can press the ASR OFF switch to disable the ASR system.

ASR OFF Switch → Refer to page 4-121

Four Wheel Drive (4WD) Model



CAUTION

- Even a 4WD vehicle does not exempt you from safe driving practices. Operate the accelerator pedal, steering wheel and brake pedal with the same level of caution as when driving a standard rear-wheel drive vehicle.

Part-time 4WD Model

A part-time 4WD model can be switched between 2WD and 4WD operation using the 4WD switch. In addition, the transfer gear control switch changes between the "HIGH" and "LOW" ranges.

Freewheel Hub

The freewheel hubs are devices that allow the front wheels and the drive shaft to be manually connected and disconnected.



CAUTION

- Whenever driving in 4WD mode, confirm that the knobs on the freewheel hubs are set to the "LOCK" position.
- Do not press the 4WD switch when driving with the knobs on the freewheel hubs in the "FREE" position. Doing so could cause the transfer case to fail.



ADVICE

- Do not set the knobs midway between the "FREE" and "LOCK" positions.
- In order to ensure sufficient lubrication of the front-wheel drive system, drive approximately 20 km (12 miles) every month with the left and right freewheel hubs in the "LOCK" position.
- The knob of the left and right freewheel hubs can become hot after driving.
- Whenever setting the freewheel hub in the lock or free position, always do so on both sides of the vehicle.

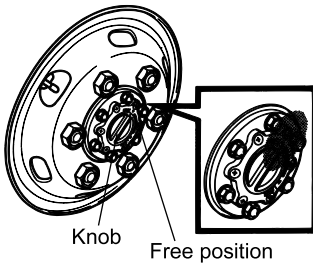

"FREE" Position

When a freewheel hub's knob is in the "FREE" position, the wheel is disconnected from the drive shaft.

This position should be used for driving in 2WD mode.

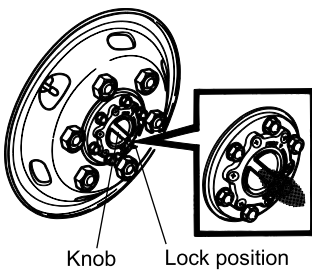

"LOCK" Position

When a freewheel hub's knob is in the "LOCK" position, the wheel is connected to the drive shaft for 4WD operation.

This position must be used for driving in 4WD mode.



NOTE

- Whenever driving in 4WD mode, ensure that the knobs on the left and right freewheel hubs are set to the "LOCK" position. (Even when the 4WD switch is turned "ON" for a viscous-coupling, torque split 4WD model, driving in 4WD mode is possible only when the knobs on the freewheel hubs are set to the "LOCK" position.)
- If the left and right freewheel hubs are set to the "FREE" position and the front wheels are disconnected from the drive shaft during driving in 2WD mode, rotation of the front wheels will not be transferred to the front drive system. As a result, noise and friction levels can be reduced for more economic driving.

4WD Switch

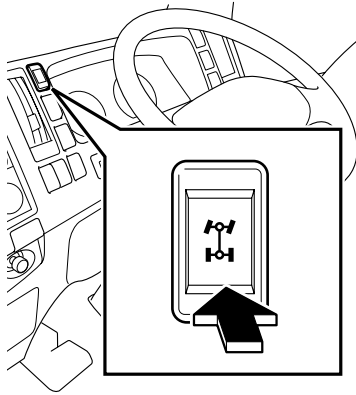



Use the 4WD switch to select 2WD or 4WD.

When using the switch, confirm in advance that the knobs on the freewheel hubs are in the "LOCK" position, and set the switch only when the vehicle is stopped or moving at low speed.

CAUTION

- Driving in 4WD mode on dry, well-paved roads can accelerate wearing of the front tyres and reduce fuel efficiency. As this action can also increase vehicle noise levels and lead to drive system damage, 2WD should always be used under these driving conditions.
- Whenever driving in 4WD mode, confirm that the knobs on the freewheel hubs are set to the "LOCK" position.
- Do not press the 4WD switch when driving with the knobs on the freewheel hubs in the "FREE" position. Doing so could cause the transfer case to fail.

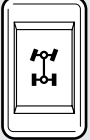
Guidelines for 2WD to 4WD Switching

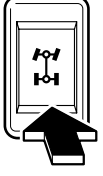
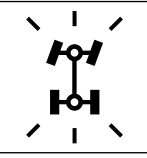
Drive mode	4WD switch	4WD indicator light	Usage conditions
2WD			During normal driving on an ordinary road or highway.
4WD			When driving on snow-covered, icy, steep or other roads that cannot easily be negotiated with 2WD.

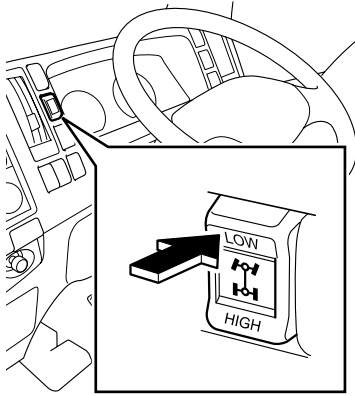
Transfer Gear Control Switch v

Transfer LOW indicator light

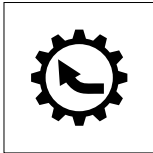

This switch is used to change between the "HIGH" range (high speed) and the "LOW" range (low speed) of the transfer case.

1. Make sure that the vehicle is stopped and depress the clutch pedal.

**NOTE**

- The clutch pedal must be depressed before the transfer gear control switch can become active.

2. Press the "HIGH" side or "LOW" side of the switch. When the "LOW" side of the switch is pressed, the transfer low indicator light comes on.

HIGH : Press this side for normal driving on a general road or highway.

LOW : Press this side for driving on a snowy road, icy road, steep slope or rough terrain.

**ADVICE**

- Do not operate the transfer gear control switch while driving. Be sure to bring the vehicle to a stop and operate the switch while depressing the clutch pedal.

**NOTE**

[Part-time 4WD model]

- If the 4WD switch is placed in the "OFF" position, pressing the "LOW" side of the transfer gear control switch does not put the vehicle into the 4WD mode.
- The transfer low indicator light does not come on unless the vehicle is in the 4WD mode (the 4WD switch is placed in the "ON" position).

3. Make sure that the transfer low indicator light is on and then start driving.

Power Take-Off (PTO)

PTO is a device that is used to provide engine power to special equipment directly from the engine or through the transmission. This manual describes an operation of PTO, but for an operation of special equipment other than the PTO lever and PTO switch, consult **[Instruction Manual for Special Equipment]**.

When Operating the PTO



CAUTION

- Make sure that there are no persons or objects around and above the vehicle before operating PTO.
- Operate PTO on a level surface.
- When operating the PTO and special equipment, be sure to place the gearshift lever into the "N" position, firmly pull the parking brake lever and keep the brake pedal fully depressed with your right foot.
- Do not operate PTO and/or special equipment while the vehicle is moving.
- For operation of special equipment, consult the separate **[Instruction Manual for Special Equipment]**.



ADVICE

- The PTO of the AMT model cannot be engaged when the engine speed is 800 r/min or higher to prevent a failure of the system. However, the PTO can be engaged at engine speeds of up to 1,200 r/min during diesel particulate defuser (DPD) regeneration or upon startup of a cold engine (when the quick-warm system is activated). The PTO cannot be engaged during fast idle control immediately after cold engine startup or when the engine speed is increased with the idling control knob. Wait until engine warm up completes or return the idling control knob to the lowest setting before operating the PTO switch.
- While operating the PTO of the vehicle equipped with DPD, the DPD system will continue to filter the exhaust and accumulate soot. The engine control system, depending on the speed and load being applied by the PTO, may not be able to generate enough energy or adequate heat needed to clean or regenerate the filter. Continued operation under conditions that do not allow effective regeneration or cleaning will eventually plug the filter and result in reduced power. The check engine warning light will be displayed, and dealer service will be required to return the vehicle to normal operation. To prevent this from occurring, frequently monitor the vehicle during PTO operation, paying particular attention to the DPD manual regeneration indicator light (amber) if the vehicle is not equipped with multi-information display (MID) or the "PUSH DPD SWITCH" message (amber) if the vehicle is equipped with MID.

**NOTE**

[Fast idle control]

- A supplementary function to warm up the engine by automatically increasing the idling speed while the engine is cold.

Lever-type PTO SA

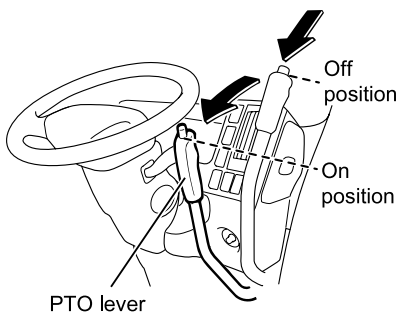
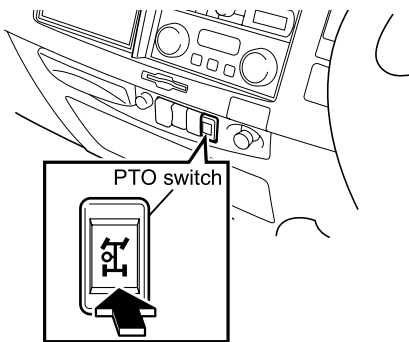
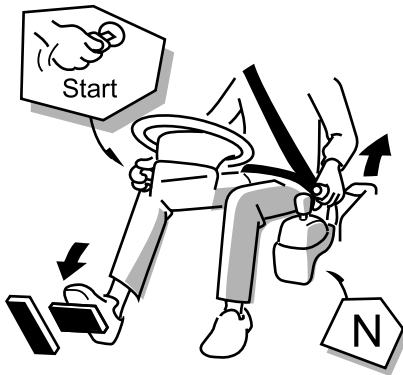

To Engage the PTO

1. Fully pull up the parking brake lever, and with the vehicle at a complete stop, set the gearshift lever in the "N" position. Then, start the engine.
2. Press the PTO switch, and while the buzzer is making **short, repeated beeps**, lower the PTO lever to engage the PTO.
3. The buzzer pattern will change to **short, slow beeps**, and the clutch will automatically engage.
4. Operate the special equipment's control switch.

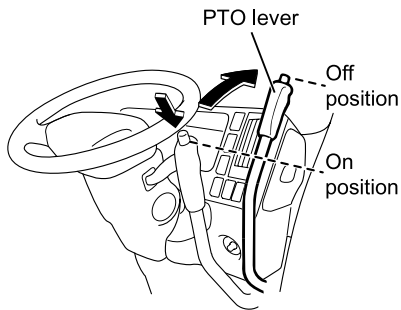
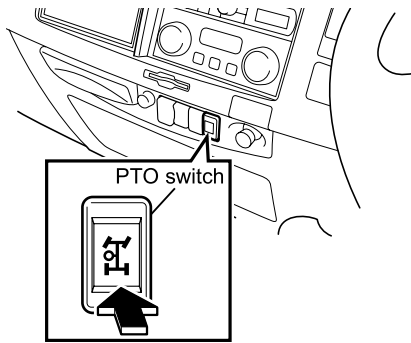

To Disengage the PTO

Press the PTO switch. While the buzzer is making **short, repeated beeps**, press the lock button on the PTO lever and move the lever from the "ON" position to the "OFF" position.

CAUTION

- Before starting the vehicle, you should confirm the following.
 - The special equipment is in a safe condition for driving.
 - The PTO lever and the PTO switch are in the "OFF" position.

NOTE

- Press the PTO switch and then operate the PTO lever within approximately 10 seconds.
- If it is not possible to operate the PTO lever within approximately 10 seconds, press the PTO switch once again, and then operate the lever.

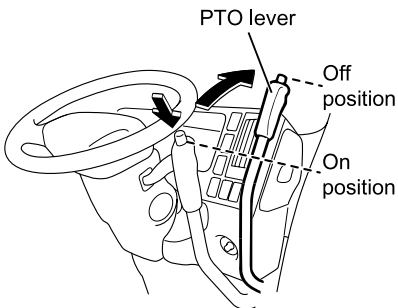
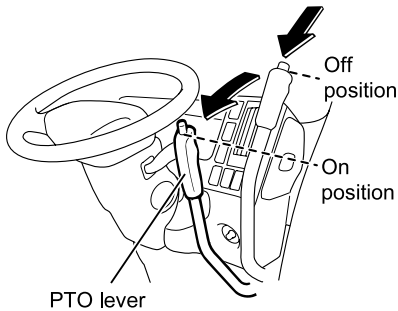
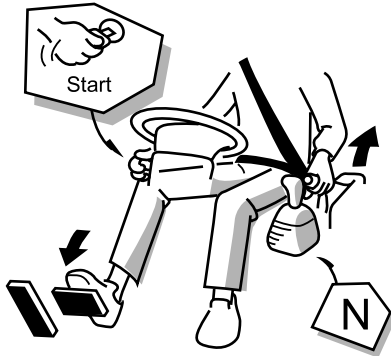
Lever-type PTO M/T**To Engage the PTO**

1. Fully pull up the parking brake lever, and with the vehicle at a complete stop, set the gearshift lever in the "N" position. Then, start the engine.

2. Depress the clutch pedal fully, and after waiting for a short time, lower the PTO lever while pressing the lock button in order to engage the PTO.
3. Slowly remove your foot from the clutch pedal.

To Disengage the PTO

1. While depressing the clutch pedal, press the lock button on the PTO lever and move the lever from the "ON" position to the "OFF" position.
2. Slowly remove your foot from the clutch pedal.

**CAUTION**

- Before starting the vehicle, you should confirm the following.
 - The special equipment is in a safe condition for driving.
 - The PTO lever is in the "OFF" position.

Switch-type PTO SA

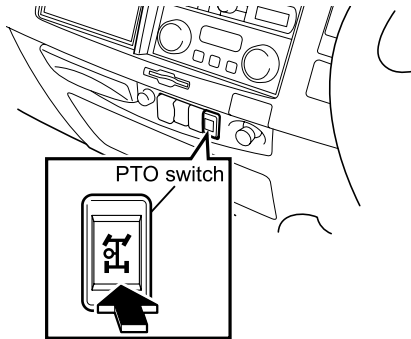

PTO indicator light

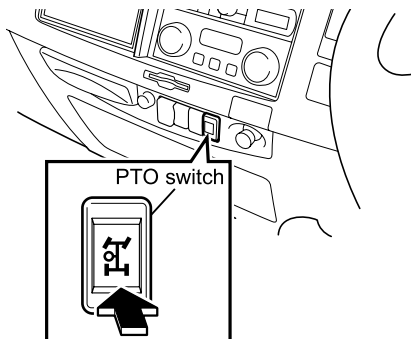
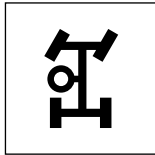
**To Engage the PTO**

1. Fully pull up the parking brake lever, and with the vehicle at a complete stop, set the gearshift lever in the "N" position. Then, start the engine.
2. Press the PTO switch. The warning buzzer will begin making **short, repeated beeps**, and the PTO indicator light in the instrument panel will come on.
3. The buzzer pattern will change to **short, slow beeps**, and the clutch will automatically engage.
4. Operate the special equipment's control switch.

To Disengage the PTO

Press the PTO switch. The warning buzzer will begin making **short, repeated beeps**, and the PTO indicator light in the instrument panel will go out. Then, the buzzer will stop.

**CAUTION**

- Before starting the vehicle, you should confirm the following.
 - The special equipment is in a safe condition for driving.
 - The PTO switch is in the "OFF" position.

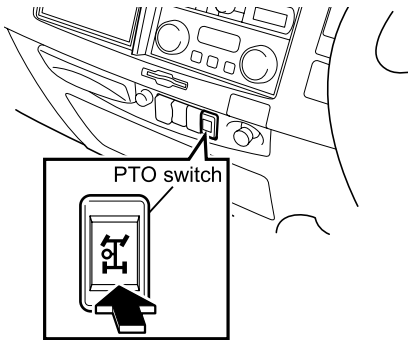
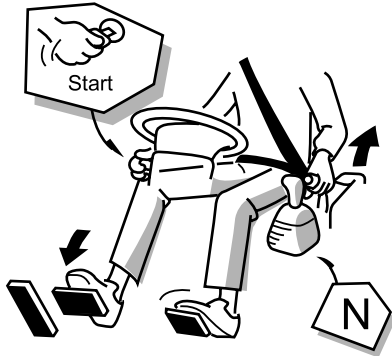
Switch-type PTO M/T

PTO indicator light

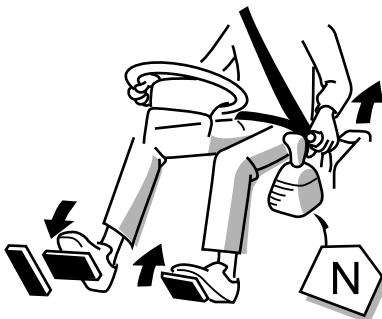
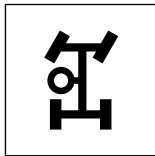
**To Engage the PTO**

1. Fully pull up the parking brake lever, and with the vehicle at a complete stop, set the gearshift lever in the "N" position. Then, start the engine.

2. Depress the clutch pedal fully, and after waiting for a short time, press the PTO switch.

At this time, the PTO indicator light in the instrument panel will come on.

**ADVICE**

- If the PTO switch is set to the "ON" position immediately after pressing down the clutch pedal, a gear grinding noise may occur or the PTO may not engage. Operating the switch before the vehicle has come to a complete stop can also have the same consequences.

3. Slowly remove your foot from the clutch pedal.
4. Operate the special equipment's control switch.

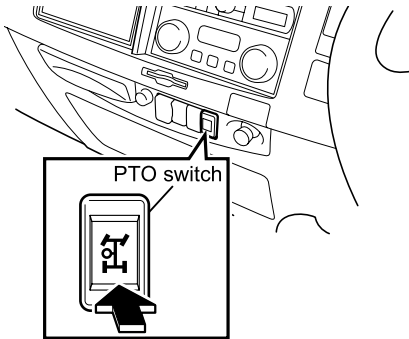

PTO indicator light

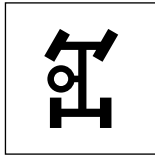

To Disengage the PTO

1. Press the PTO switch while depressing the clutch pedal. Then make sure that the PTO indicator light in the instrument panel goes out and PTO drive is stopped.
2. Slowly remove your foot from the clutch pedal.



CAUTION

- Before starting the vehicle, you should confirm the following.
 - The special equipment is in a safe condition for driving.
 - The PTO switch is in the "OFF" position.

Dump Control Lever

The dump control lever is used to raise or lower the dump body.

This section describes how to use the dump control lever of a dump truck.

For operation of the controls other than the dump control lever, please refer to the separate "Instruction Manual for Dump Truck".



CAUTION

- During driving and maintenance of the vehicle, be sure to place the dump control lever into the "DOWN" position and make sure that the dump control lever is fixed by the lock button and is not activated.
- Do not hold onto the dump control lever when getting into or out of the cab. Doing so is very dangerous should the lever be moved accidentally.

Basic Operation of Dump Control Lever

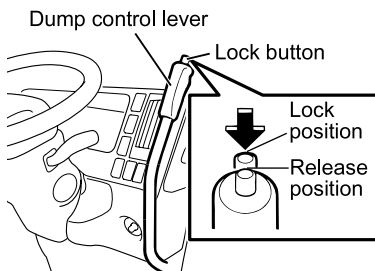

Operation of Lock Button

Releasing the lock button with the dump control lever in either of the "DOWN" or "UP" position causes the control lever to be fixed in that position.

Be sure to press and hold the lock button when operating the dump control lever.

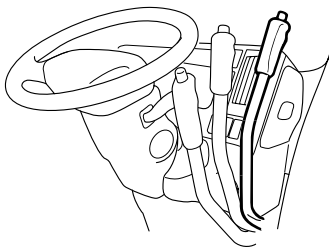

To Lower the Dump Body

Shown with a thick line in the drawing at left is the lever position to lower the dump body.

Note that the lever should be fixed in this position in normal situations, whether driving or stationary.

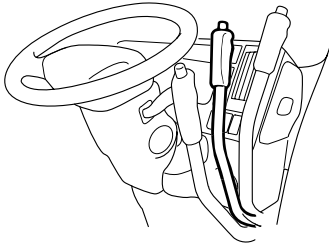

To Temporarily Stop the Dump Body

Shown with a thick line in the drawing at left is the lever position to temporarily stop the dump body during raising or lowering. Never leave the driver's seat while placing the lever in this position.



CAUTION

- The dump control lever cannot be secured in this position using the lock button.

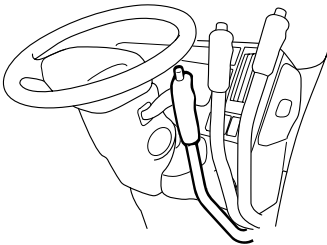

To Raise the Dump Body

Shown with a thick line in the drawing at left is the lever position to raise the dump body.

In addition, when the dump body is to be left in a raised position, secure the lever in this position and support the dump body by a safety bar.



CAUTION

- The dump control lever cannot be secured in the "Temporary Stop" position. This position must be used only to stop raising or lowering of the dump body temporarily.
- If the dump control lever is set in the "Temporary Stop" position in order to hold the dump body in an intermediate position for a considerable period of time, there is a danger that the dump body may suddenly rise or fall. This action is, extremely hazardous and must be avoided. When the dump body is to be held in the raised position, ensure that it is fully raised, stop the engine, fix the dump control lever in the "UP" position, and support the dump body by a safety bar.

When Operating the Dump Body



CAUTION

- When operating the dump control lever to raise or lower the dump body, make sure that there are no persons or objects near or above the vehicle.
- Only raise or lower the dump body with the vehicle positioned on a level surface. Operating the dump body on an inclined surface can lead to the vehicle toppling over. Such an operation should never be attempted.
- When operating the dump control lever, the vehicle must have come to a complete stop, the parking brake lever must be fully pulled and you must keep the brake pedal fully depressed with your right foot.
- Do not operate the dump body when driving.



ADVICE

- The PTO of the AMT model cannot be engaged when the engine speed is 800 r/min or higher to prevent a failure of the system. However, the PTO can be engaged at engine speeds of up to 1,200 r/min during diesel particulate defuser (DPD) regeneration or upon startup of a cold engine (when the quick-warm system is activated). The PTO cannot be engaged during fast idle control immediately after cold engine startup or when the engine speed is increased with the idling control knob. Wait until engine warm up completes or return the idling control knob to the lowest setting before operating the PTO switch.
- While operating the PTO of the vehicle equipped with DPD, the DPD system will continue to filter the exhaust and accumulate soot. The engine control system, depending on the speed and load being applied by the PTO, may not be able to generate enough energy or adequate heat needed to clean or regenerate the filter. Continued operation under conditions that do not allow effective regeneration or cleaning will eventually plug the filter and result in reduced power. The check engine warning light will be displayed, and dealer service will be required to return the vehicle to normal operation. To prevent this from occurring, frequently monitor the vehicle during PTO operation, paying particular attention to the DPD manual regeneration indicator light (amber) if the vehicle is not equipped with multi-information display (MID) or the "PUSH DPD SWITCH" message (amber) if the vehicle is equipped with MID.



NOTE

[Fast idle control]

- A supplementary function to warm up the engine by automatically increasing the idling speed while the engine is cold.

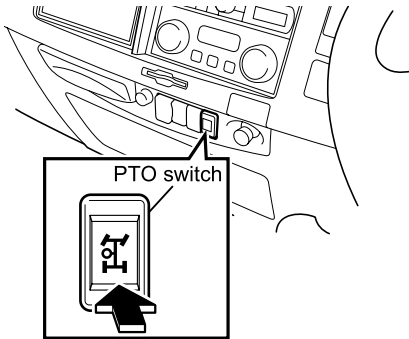

When Raising the Dump Body (Model with AMT)

1. Fully pull up the parking brake lever, and with the vehicle at a complete stop, set the gearshift lever in "N". Then, start the engine.
2. Press the PTO switch and make sure that the buzzer starts making **short, repeated beeps**.
3. Pull the dump control lever upward towards the "UP" position. The buzzer pattern will change to **short, slow beeps** and the dump body will rise. Once the dump body has reached the highest possible position, it will stop automatically.



ADVICE

- Simply operating the dump control lever alone will not cause the dump body to rise. Before operating the lever, be sure to press the PTO switch and make sure that the buzzer starts sounding.

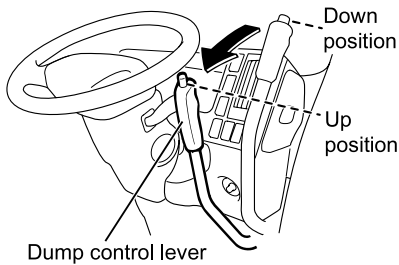

CAUTION

- If the dump body is to be raised once again after stopping the engine, be sure to place the PTO switch into the "OFF" position before restarting the engine and then operating the dump body. If this sequence is not followed, the dump body will not rise.

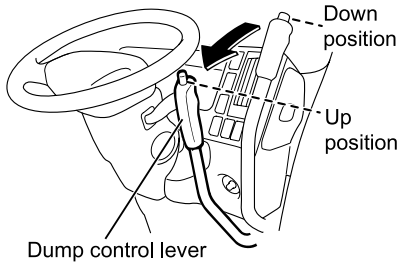
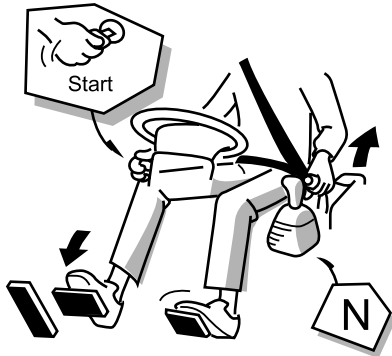

When Raising the Dump Body (Manual Transmission Model)

1. Fully pull up the parking brake lever, and with the vehicle at a complete stop, set the gearshift lever in "N". Then, start the engine.
2. Depress the clutch pedal fully, and after waiting for a short time, move the dump control lever to the "UP" position.
3. Slowly remove your foot from the clutch pedal. The dump body will begin to rise.

Once the dump body has reached the highest possible position, it will stop automatically.

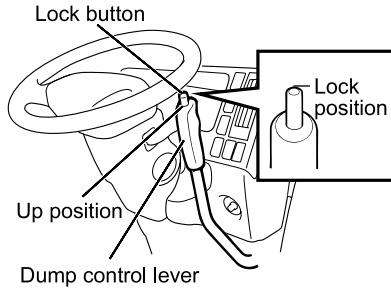

When Leaving the Dump Body Raised



CAUTION

- When the dump body is to be left in the raised position for cleaning, inspection or the like, always position the vehicle on a level surface, fully engage the parking brake, apply chocks to the wheels, ensure that the dump body is empty and support the dump body using a safety bar, safety posts or the like to prevent the body from falling.
- Wheel chocks and safety posts must both be used when performing inspections or maintenance with the dump body left in the raised position.
- Ensure that only persons authorized to work on the vehicle can enter the area below the dump body.

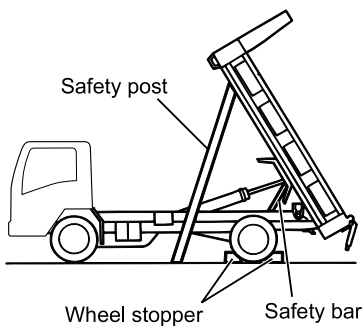

1. Place the dump control lever located in the cab in the "UP" position, and make sure that the lever is locked in place.
2. Always stop the engine when the dump body reaches the highest possible position.
3. Insert a safety bar to support the dump body in place.
Before working underneath the raised dump body, always apply chocks to the wheels to prevent the vehicle from moving and support the dump body with safety posts to prevent the dump body from falling.

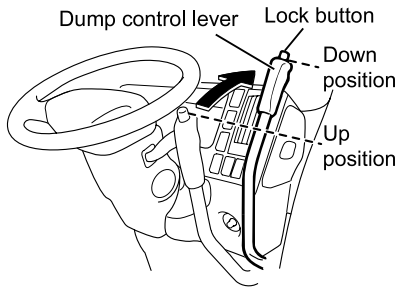

When Lowering the Dump Body (Model with AMT)

1. Press the lock button on the dump control lever, and move the lever from the "UP" position to the "DOWN" position. The dump body will lower by gravity.
2. Press the PTO switch. The buzzer will stop sounding.

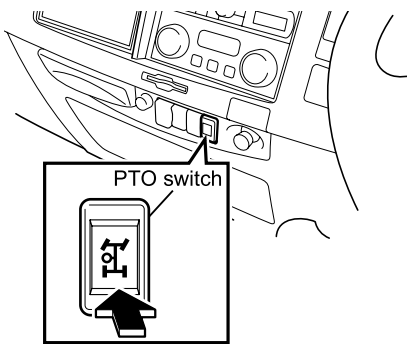

NOTE

- A PTO gear grinding noise may occur when the dump control lever is moved back to the "UP" position in order to raise the dump body after it has been moved to the "DOWN" position. This does not indicate any abnormal condition. The gear grinding noise can be avoided, however, by returning the lever to the "DOWN" position, pressing the PTO switch to stop the warning buzzer, again pressing the PTO switch and then operating the dump control lever.

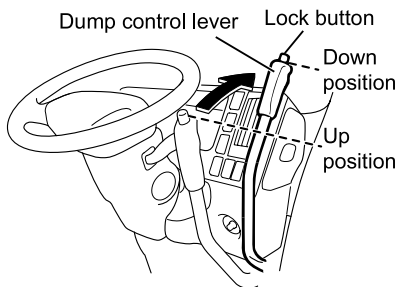

When Lowering the Dump Body (Manual Transmission Model)

Press the lock button on the dump control lever, and move the lever from the "UP" position to the "DOWN" position. The dump body will lower by gravity. At this time, the PTO indicator light in the instrument panel will go out.

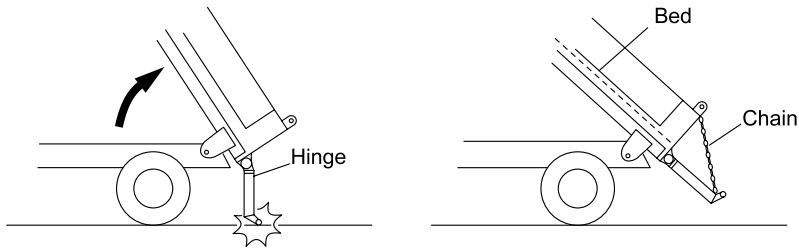

CAUTION

- Before starting the vehicle, you should confirm the following.
 - The dump body has been fully lowered.
 - The dump control lever has been securely locked in the "DOWN" position and cannot move the dump body.
 - Each gate is firmly secured in place.
- In order to avoid overloading the dump mechanism when lowering the dump body, move the dump control lever slowly.
- Pay special attention to the following points regarding opening and closing of the rear gate (and left and right gates on the three-way dump) of the bottom-hinged types.
 - Never attempt opening or closing of bottom-hinged gates when the dump body is in the raised position. If this precaution is not observed, there is a danger that the gate and cargo may drop from the cargo bed. These operations should be performed only when the dump body has been fully lowered.
 - Avoid raising the dump body when a bottom-hinged gate is open. If this precaution is not observed, the gate can collide with the ground, damaging the hinges; in addition, the bottom hinge may detach, causing the gate to fall.
 - In order to keep a bottom-hinged gate in an open position while raising and lowering the dump body, use a chain or the like to keep it flat to the cargo bed. Ensure that there is sufficient clearance between the rear gate and the ground when the dump body is raised.
- Take particular care when opening side or rear gates with cargo present on the cargo bed.
Falling cargo can be extremely dangerous.
- Usage of the cargo bed for work operations while in the raised position is extremely dangerous. When you must climb onto the cargo bed, ensure that it is fully lowered before doing so.

**NOTE**

- Chains are available as special equipment. Please contact your Isuzu Dealer.

Seat Belt with Pretensioner and SRS Airbag System V

The seat belt with pretensioner and supplemental restraint system (SRS) airbag system is activated in the event of a frontal collision when the impact energy exceeds a certain level to help mitigate the shock on the head of the driver (and the passenger, if the passenger side airbag is equipped) by firmly restraining the body of the occupant in the seat with the pretensioner seat belt and airbag. Be sure to observe the following instructions to prevent you and your passenger from suffering a serious or fatal injury due to impacts resulting from the seat belt with pretensioner and airbag operation.

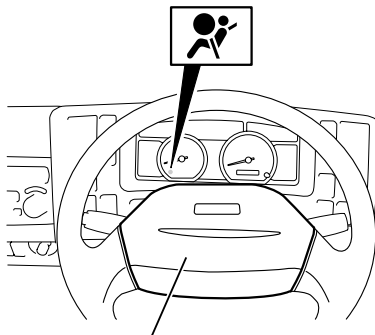
Operation Check

Airbag assembly for driver seat

The SRS airbag warning light should flash seven times when the starter switch is turned to the "ON" position, and then should go out.

If the SRS airbag warning light stays on, the airbag(s) may not function properly when needed.

**CAUTION**

- If the warning light does not initially flash seven times, does not go out or comes on during driving, promptly have your vehicle inspected/ serviced at the nearest Isuzu Dealer.

 **WARNING**

- If you make unauthorized modifications to the vehicle or install an unauthorized accessory, the pretensioner seat belt and airbag may not operate correctly.
- If the steering wheel is changed to a non-standard one or a sticker is attached to the steering wheel pad, there could be a danger of system malfunction or the sticker flying off in the event of system activation. Attaching stickers or placing such things as accessories or air fresheners on the top surface of the instrument panel is also dangerous. They may prevent normal operation of the airbag or could fly off in the event of system activation.
- Doing any of the following may require special precautions. Be sure to consult your Isuzu Dealer before doing any of the following. Failure to do so may cause the pretensioner seat belt and airbag to be unduly activated, causing the seat belt to be unexpectedly retracted or the airbag to be suddenly inflated, causing an injury to the occupant. Doing any of them improperly will adversely affect the operation of the system, causing a malfunction or failure.
 - Repair or replacement of the steering wheel, instrument panel, centre console and parts around the accelerator pedal.
 - Repair, replacement or disposal of the pretensioner seat belts and airbag, or scrapping of a vehicle that has pretensioner seat belts and airbag.
 - When audio equipment and accessories are installed or modification such as body mounting is carried out.
 - Repainting of vehicle front and cab panels.

 **CAUTION**

Have your vehicle inspected at your nearest Isuzu Dealer promptly if you encounter any of the following conditions.

- The SRS airbag warning light shows an abnormality.
- The pretensioner seat belt and airbag are activated by an impact. (The SRS airbag warning light comes on.)
- Your vehicle has received a significant level of frontal impact even when the impact has not activated the pretensioner seat belt and airbag.
- The seat belt is frayed or worn out.
- The steering pad surface is cracked or otherwise damaged, or it receives a significant level of impact.
- The instrument panel surface is cracked or otherwise damaged, or it receives a significant level of impact.

SRS Airbag Warning Light

→ Refer to page 4-34

Seat Belt with Pretensioner

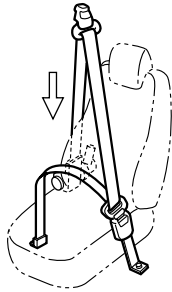

When the vehicle receives an impact exceeding a certain level during a frontal collision, the pretensioner causes the seat belt to be retracted instantly and removes the slack in the seat belt to securely restrain the occupant in the seat, thus enhancing the seat belt's restraining effect.

Seat Belts → Refer to page 3-23

WARNING

- The seat belt with pretensioner helps reduce the risk of a serious injury to the occupant should the vehicle receive a frontal impact exceeding a certain level. The maximum effect is achieved only if the seat belt is correctly worn.
- The seat belt with pretensioner takes up the slack in the seat belt instantly to help reduce the risk of a serious injury. If the seat belt with pretensioner activates, you may suffer a slight bruise or burn due to heat generated by rubbing.

CAUTION

- Do not remove or disassemble the seat belt. Accidental activation of the system may cause parts to fly off, causing an injury to you; or causing malfunction.

ADVICE

- Once activated during a collision, the seat belt with pretensioner cannot be reused. The seat belt must be replaced immediately at the nearest Isuzu Dealer.

NOTE

- Even if the pretensioner function fails, the seat belt still operate as a regular seat belt (with ELR).
- The pretensioner generates a sound at the moment it retracts the seat belt.
- When the seat belt with pretensioner and airbag system is activated by an impact, the warning light comes on.

Supplemental Restraint System (SRS) Airbag

The SRS airbag, when it inflates, helps to disperse and reduce the impact on the occupant's body, as a supplement to the seat belt with pretensioner.

This occurs when there is an impact exceeding a certain level.

WARNING

- The airbag supplements the occupant protection effect of the seat belt by being activated together with the pretensioner seat belt to reduce severity of injury to the occupant should the vehicle receive a frontal impact exceeding a certain level. The maximum effect is achieved only if the seat belt is correctly worn.
- The airbag does not replace the seat belt. Be sure to wear the seat belt.
- The airbag is instantly inflated with considerable force to reduce serious injury. If the airbag inflates, you may suffer a slight bruise or burn due to heat generated by rubbing.
- When the vehicle receives an impact exceeding a certain level, resulting in airbag deployment, deformation of the vehicle may cause the windshield to break.

ADVICE

- When the airbag is inflated, a sound and white smoke are produced but this is not the result of a fire. This white smoke is not detrimental your health. However, if residue (gas and so on) adheres to your eyes and skin, rinse them with water as soon as possible. Although it is rare, a person with delicate skin may suffer from irritation.
- Immediately after the airbag is inflated, the metal portion that inflates the airbag gets hot. Do not touch it.
- The airbag cannot be reused once it is inflated. Immediately replace it at the nearest Isuzu Dealer.

NOTE

- The airbag is quickly deflated after deployment and does not hinder visibility.
- When the seat belt with pretensioner and airbag are activated by an impact, the SRS airbag warning light comes on.

When and How the Seat Belt with Pretensioner and SRS Airbag System Operates

The seat belt with pretensioner and airbag system are activated when the vehicle receives an impact exceeding a certain level in the event of a frontal collision. Because the vehicle body absorbs part of impact energy, the system may not be activated due to reduction in the force of the impact or the intensity or direction of the impact received. However, even if the front of the vehicle is largely deformed by the collision, in some cases the impact on the seat is not severe. Therefore, the severity of deformation of and damage to the vehicle do not necessarily coincide with the activation of the airbag.

When are the Seat Belt with Pretensioner and SRS Airbag System Activated?

When the vehicle collides head-on against a parked/stopped vehicle or a moving vehicle with an impact of a certain level or higher

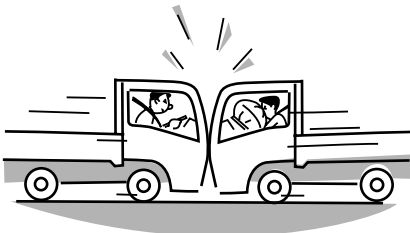

When the vehicle collides head-on against a solid wall with an impact of a certain level or higher



WARNING

- Immediately after the airbag is inflated, the metal portion that inflates the airbag gets hot. Do not touch it. Doing so may cause a serious injury such as a burn.

When are the Seat Belt with Pretensioner and SRS Airbag System Not Likely to Be Activated?

In the following cases, the seat belt with pretensioner and SRS airbag system are less likely to be activated even if they are working properly.

When the vehicle collides against a utility pole or standing tree



When the vehicle gets under an obstacle or vehicle

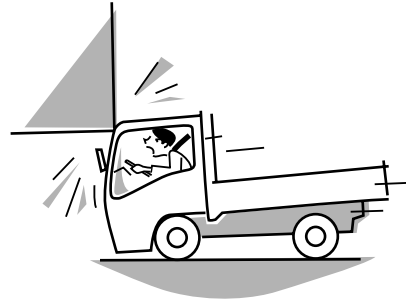

When the vehicle has an offset collision (one-sided collision)

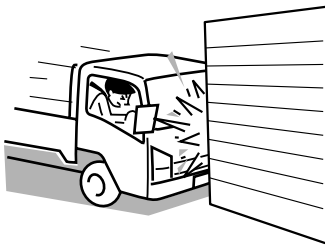

When the vehicle has a frontal angle collision

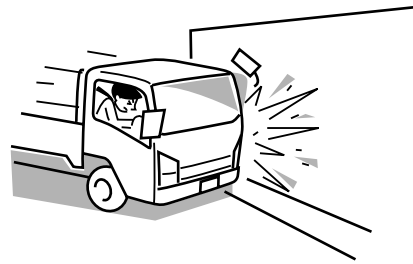

When are the Seat Belt with Pretensioner and SRS Airbag System Activated Other than in a Collision?

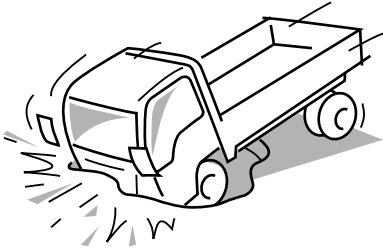

- When the vehicle falls into a pothole or groove in the road
- When the vehicle strongly collides against an obstacle such as a protruding object on the road
- When the vehicle collides against a curb at high speed
- When the vehicle becomes airborne and hits the ground, receiving a strong impact on the bottom of the vehicle

WARNING

- Immediately after the airbag is inflated, the metal portion that inflates the airbag gets hot. Do not touch it. Doing so may cause a serious injury such as a burn.

When are the Seat Belt with Pretensioner and SRS Airbag System not Activated?

In the following cases, the seat belt with pretensioner and airbag system are not activated even if they are working properly.

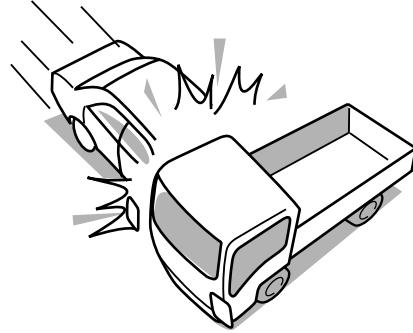
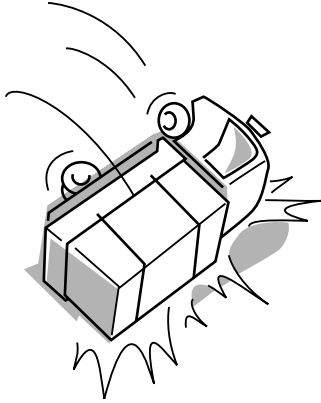
When the vehicle is hit from the rear**When the vehicle is hit from the side****When the vehicle rolls onto its side or upside down**

 **WARNING**

- Body repair and paint of the cab, repair around the side panel, steering wheel, instrument panel and centre console, installation of accessories such as audio equipment and repair around the dashboard may adversely affect the airbag system or cause a fatal or serious injury due to the impact of the airbag when it unexpectedly inflates. Never make these repairs by yourself, but be sure to consult your Isuzu dealer.
- If you make modifications to the front of the vehicle (bumper, frame, etc.), install equipment (snow plow, for example), or make a change the vehicle's height using unauthorized methods and/or materials, the airbag system may fail to operate normally. Be sure to consult your Isuzu Dealer.
- Special treatment is required when an airbag is disposed of. When discarding a vehicle equipped with an airbag system, consult your Isuzu Dealer.

 **CAUTION**

Have your vehicle inspected at the nearest Isuzu dealer at once in the following cases.

- When the SRS airbag warning light does not go out or comes on during driving.
- When the airbag is inflated.
- When the airbag was not inflated although the vehicle received a significant level of impact at the front.
- When the steering pad surface is cracked or otherwise damaged or it receives an impact.
- When the instrument panel surface is cracked or otherwise damaged or it receives an impact.

 **NOTE**

- When the airbag is inflated, gases like white smoke are produced but this is not a fire. This white smoke is not detrimental to your health. However, if residue (gas and so on) adheres to your eyes and skin, rinse them with water as soon as possible. Although it is rare, a person with delicate skin may suffer from irritation.
- The airbag cannot be reused once it is inflated. Replace it at your Isuzu Dealer.

Deployment of SRS Airbag

When the vehicle collides head-on with an impact of a certain level or higher, the airbag system is activated and airbag instantly inflates. It deflates quickly and does not hinder visibility.

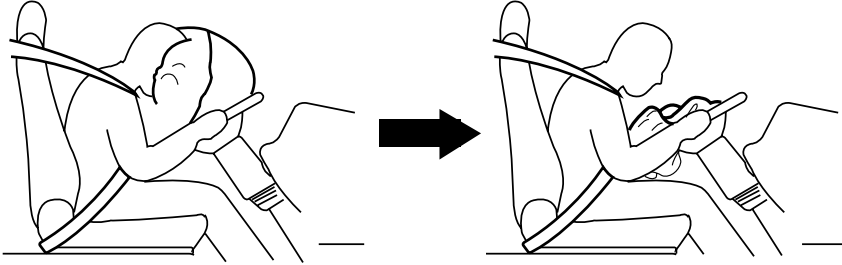

When Does An SRS Airbag Develop Its Full Effect?

WARNING

- Before driving the vehicle, properly adjust your seat for the correct driving position and wear the seat belt correctly. Do not sit closer than necessary to the steering wheel and do not lean over it. If your vehicle is equipped with a passenger's airbag, do not allow the passenger to put his/her hands or feet on the instrument panel and to sit with his/her face or chest close to it. When the airbags are activated, you or the passenger may suffer a burn on or serious injury to the arm or face. Attaching stickers or placing such things as accessories or air fresheners on the instrument panel is also dangerous. They may prevent normal operation of the airbags or would fly off in the event of airbags activation.
- If the steering wheel is changed to a non-standard one or a sticker is attached to the steering wheel pad, there would be a danger of system malfunction or the sticker flying off in the event of airbag activation.

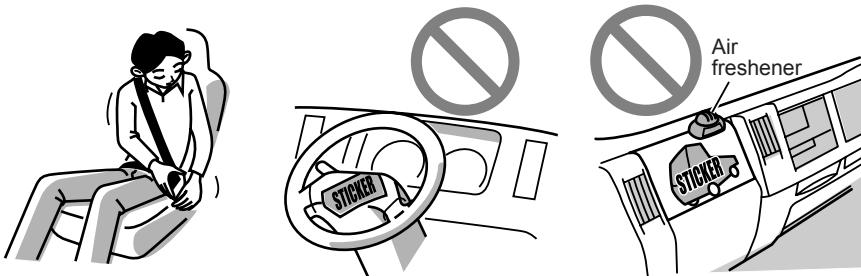

When Carrying a Child in the Vehicle

WARNING

- Be sure to observe the following precautions when carrying a child in the vehicle. Otherwise the child may be fatally injured by the impact from an inflating airbag.
 - Do not drive with a child standing in front of the passenger's airbag or held on your lap. Doing so is dangerous because the child would receive a very strong impact by an inflating airbag.
 - Do not install a rear-facing infant or child seat on the passenger seat if your vehicle is equipped with a passenger's airbag. An inflating passenger's airbag could cause the child to be fatally injured.

Handling of SRS Airbag

WARNING

- Do not remove or disassemble the airbag. Doing so may cause a malfunction or inadvertent activation.
- Do not place anything near the airbag. You may suffer an injury when an object is thrown by the inflation force of the airbag.
- Do not take a rest using the steering wheel as a pillow or with your arms or legs resting on it. If the vehicle is stopped with the starter switch in the "ON" position and an impact greater than the airbag activation level occurs to the front of the vehicle, the airbag will injure you.
- Do not drive the vehicle with something placed between you and airbag or held on your lap. If the airbag inflates, the objects may be thrown and hit your face. Doing so also hinders normal activation of the airbag, which is dangerous.
- Do not wet the airbag sensor with water or subject it to an impact. The system may malfunction; this is very dangerous.



Diesel Particulate Defuser (DPD)

The DPD purifies particulate matter (PM) in exhaust gases. The DPD collects PM in the DPD filter and when PM is collected in the filter to the predetermined level, the DPD automatically burns PM (regeneration the filter). We recommend that you observe the following instructions to keep the DPD in order.

DPD PM Accumulation Level

→ Refer to page 4-27

Progress of DPD Regeneration

→ Refer to page 4-27

DPD Switch

NLR/NNR/NPR/NQR/NPS models (model without HSA)

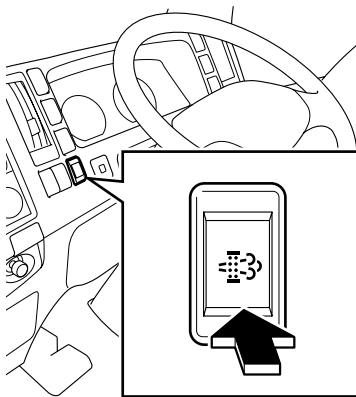

The DPD switch is used to manually burn PM (regenerate the filter).

You should take the steps for manually regenerating the DPD when the DPD manual regeneration indicator light (amber) flashes if your vehicle is not equipped with multi-information display (MID) (the flashing occurs at about one-second intervals and is accompanied by "a short beep" of a warning buzzer), or when the "PUSH DPD SWITCH" message (amber) flashes if your vehicle is equipped with MID (the flashing occurs at about one-second intervals and is accompanied by "short, repeated beeps" of a warning buzzer). Perform the manual regeneration of the DPD while parking the vehicle after the day's operation, for example, following the instructions under "DPD Manual Regeneration Procedure".

If you continue driving with the light or message flashing at about once per second (1 Hz) intervals, the flashing intervals will change to shorter ones (about 3 times per second (3 Hz) intervals). If you continue driving in this state too long, the DPD may fail. Stop the vehicle at a safe place immediately and perform the manual regeneration.

**NLR/NNR/NPR/NQR/NPS models
(model with HSA)**

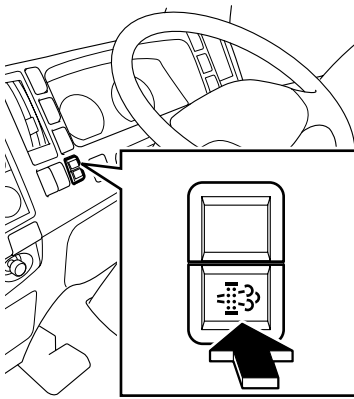

Model without MID

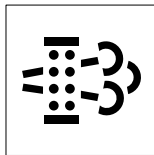

(Amber, flashing)

Model with MID



(Amber, flashing)



ADVICE

- Continuing driving without performing the regeneration will cause the check engine warning light to come on. The DPD then must be repaired at the nearest Isuzu Dealer.



NOTE

- The DPD automatically burns PM (regenerates the filter) when a certain amount of PM is accumulated in the DPD filter, but the automatic regeneration may not be completed in certain driving conditions. If this occurs, the DPD manual regeneration indicator light (amber) will flash if your vehicle is not equipped with MID, or the "PUSH DPD SWITCH" message (amber) will flash if your vehicle is equipped with MID. Promptly take the manual regeneration steps according to the instructions described later. The manual regeneration is necessary to recover the DPD function. It is not an action to take after occurrence of a DPD failure.

DPD Manual Regeneration Procedure



1. Stop the vehicle at a safe place free of flammable materials such as dead grass or wastepaper.



CAUTION

- To prevent a fire, make sure that there is no flammable material near the muffler, DPD and exhaust pipe. Remember that the temperature of exhaust gases is high enough to burn you.

2. In a manual transmission model, place the gearshift lever into the "N" position and firmly engage the parking brake.
In a AMT model, place the gearshift lever into the "N" position, confirm the "N" indication and securely pull the parking brake.
3. Run the engine at idle.
If your vehicle is equipped with an idling control knob, return it fully counterclockwise to decrease the engine speed when the engine speed has been increased using the idling control knob.
4. Stop the operation of PTO if your vehicle is equipped with a PTO. Turn off the PTO switch and the outside accelerator control.

Model without MID

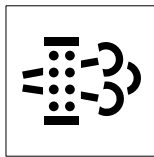

(Amber)

Model with MID



(Amber)

5. Press the DPD switch.
6. If your vehicle is not equipped with a multi-information display (MID), the DPD manual regeneration indicator light (amber) stops flashing and stays on, and the engine speed automatically increases to start regeneration. If your vehicle is equipped with a MID, the "PUSH DPD SWITCH" message (amber) stops flashing and change to a steady "MANUAL REGEN." message (amber), and the engine speed automatically increases to start the regeneration.
7. Do not leave the vehicle during the regeneration. Regeneration normally completes in about 20 minutes.

- When the DPD manual regeneration indicator light (amber) or "MANUAL REGEN." message (amber) goes out, regeneration is completed. Normal driving is then possible.

 **WARNING**

- White smoke may be produced during manual regeneration; do not perform manual regeneration in a poorly ventilated indoor place.

 **ADVICE**

- When operating the PTO for a long time if your vehicle is so equipped, make sure that the DPD manual regeneration indicator light (amber) (model not equipped with MID) or the "PUSH DPD SWITCH" message (amber) (model equipped with MID) is not flashing.

 **NOTE**

- The time needed to complete regeneration differs depending on the outside temperature.
- The exhaust brake or exhaust throttle is activated during DPD regeneration. The exhaust brake or exhaust throttle starting to operate or being disengaged will produce a sound, but this does not indicate a failure.
- During regeneration, white smoke may be temporarily produced from the exhaust pipe. This results from combustion of PM, it does not indicate a failure.
- Manual regeneration will complete earlier immediately after driving than when the engine is cold.
- The engine coolant temperature may rise during manual regeneration.

Interruption of Manual Regeneration

If you must interrupt regeneration for an unavoidable reason, press the DPD switch again.

The DPD manual regeneration indicator light (amber) starts flashing if your vehicle is not equipped with a MID or the "MANUAL REGEN." message (amber) changes to a flashing "PUSH DPD SWITCH" message (amber). Then, you can drive the vehicle. If you interrupt regeneration, you need to perform regeneration again. Perform manual regeneration beginning with Step 1 as soon as possible.

Automatic Regeneration of DPD

Model without MID

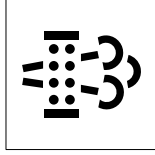

(Green, comes on)

Model with MID



(Green, comes on)

The engine speed may increase and the exhaust brake may activate while the vehicle is stopped with the engine idling. When this occurs, the DPD is automatically regenerated. This does not indicate a failure. The automatic regeneration causes the DPD automatic regeneration indicator light (green) to come on if your vehicle is not equipped with multi-information display (MID) or the "AUTO REGEN." message (green) to be displayed if your vehicle is equipped with MID.



ADVICE

- Do not press the DPD switch when the DPD automatic regeneration indicator light (green) comes on if the vehicle is not equipped with MID or the "AUTO REGEN." message (green) comes on if the vehicle is equipped with MID.



NOTE

- The engine speed may increase and the exhaust brake may activate while the vehicle is stopped with the engine idling. When this occurs, the DPD is automatically regenerated. This does not indicate a failure.
- The system generates a sound during the automatic regeneration and its cancellation. This does not indicate a failure.

Procedure for Selectable Regeneration of DPD

Perform the selectable regeneration of the DPD when the engine (coolant temperature) and exhaust pipe are still warm such as when the day's operation is finished.

CAUTION

- Perform the selectable regeneration until it is completed without interruption.
- Do not leave the vehicle during the regeneration.
- To prevent a fire, make sure that there are no flammables near the muffler, DPD and exhaust pipe.
- Remember that the temperature of exhaust gases is high enough to burn you.

1. Stop the vehicle at a safe place free of flammable material such as dead grass or wastepaper.
2. With the engine idling, ensure that the gearshift lever is placed in the "N" position for a manual transmission model or place the gearshift lever in the "N" position for a model with AMT. Then, confirm that the gearshift indicator shows "N" and fully engage the parking brake. When the engine speed is increased by operating the idling control knob in the vehicle equipped with the idling control knob, return the engine speed to the normal idling state.

Make sure that the operation of PTO is stopped if your vehicle is equipped with a PTO.

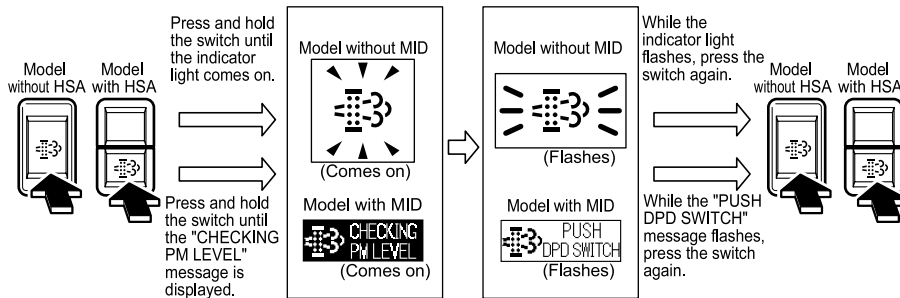

3. If your vehicle is not equipped with multi-information display (MID), press the DPD switch until the DPD manual regeneration indicator light (amber) comes on. The DPD manual regeneration indicator light (amber) will go from steadily on to flashing. If your vehicle is equipped with MID, press the DPD switch until the "CHECKING PM LEVEL" message (amber) is displayed. The "CHECKING PM LEVEL" message (amber) will then change and "PUSH DPD SWITCH" message (amber) with flashing.

4. Press the DPD switch again.
5. If your vehicle is not equipped with MID, the DPD manual regeneration indicator light (amber) stops flashing and then stays on, and the engine speed automatically increases to start regeneration.
If your vehicle is equipped with MID, the flashing "PUSH DPD SWITCH" message (amber) changes to the "MANUAL REGEN." message (amber), and the engine speed automatically increases to start regeneration.
6. Do not leave the vehicle during regeneration. Regeneration normally completes in about 20 minutes.
7. When the DPD manual regeneration indicator light (amber) (in a model without MID) or the "MANUAL REGEN." message (amber) (in a model with MID) goes out, regeneration is completed. Normal driving is then possible.

**ADVICE**

- Should the selectable regeneration be interrupted due to restart of driving, the DPD manual regeneration indicator light (amber) will start "flashing" if your vehicle is not equipped with MID, or the "MANUAL REGEN." message (amber) changes to a "flashing" "PUSH DPD SWITCH" message (amber) if your vehicle is equipped with MID. In this case, stop the vehicle safely immediately, press the DPD switch again, and wait until the selectable regeneration is completed. Do not continue driving or using the PTO, if the vehicle is so equipped, with the indicator light or the message flashing.
- When the PM level in the DPD filter is lower than the preset level, the DPD manual regeneration indicator light (amber) does not change from "steady illumination" to "flashing" if your vehicle is not equipped with MID even if the DPD switch is kept pressed. Likewise, the "CHECKING PM LEVEL" message (amber) does not change to a "flashing" "PUSH DPD SWITCH" message (amber) if your vehicle is equipped with MID. In either case, the DPD does not require regeneration, so it ignores the DPD switch operation.

**WARNING**

- White smoke may be produced during regeneration. Do not perform regeneration in a poorly ventilated indoor place.

**NOTE**

- The time needed to complete regeneration differs depending on the outside temperature.
- The exhaust brake or exhaust throttle is activated during DPD regeneration. The exhaust brake or exhaust throttle starting to operate or being disengaged will produce a sound, but this does not indicate a failure.
- During regeneration, white smoke may be temporarily produced from the exhaust pipe. This results from combustion of PM, it does not indicate a failure.
- Regeneration is finished earlier immediately after driving than when the engine is cold.
- The engine coolant temperature may rise during regeneration.



COMFORT AND CONVENIENCE

5

• Air Outlets	5-2
• Ventilator <input type="checkbox"/>	5-3
• Heater/Manual Air Conditioner <input type="checkbox"/>	5-5
• Automatic Air Conditioner <input type="checkbox"/>	5-12
• Interior Lights	5-20
• Sun Visor	5-21
• Cigarette Lighter	5-22
• Ashtray <input type="checkbox"/>	5-23
• Small Article Storage Pocket <input type="checkbox"/>	5-25
• Card Holder	5-25
• Glove Compartment <input type="checkbox"/>	5-26
• Centre Console Box <input type="checkbox"/>	5-26
• Overhead Tray <input type="checkbox"/>	5-27
• Cup Holder <input type="checkbox"/>	5-27
• Back Panel Tray (Storage Receptacle) <input type="checkbox"/>	5-28
• Coat Hook <input type="checkbox"/>	5-29
• Hook	5-29
• Operating Tips for the Radio and CD Player	5-30
• Antenna	5-31

Air Outlets

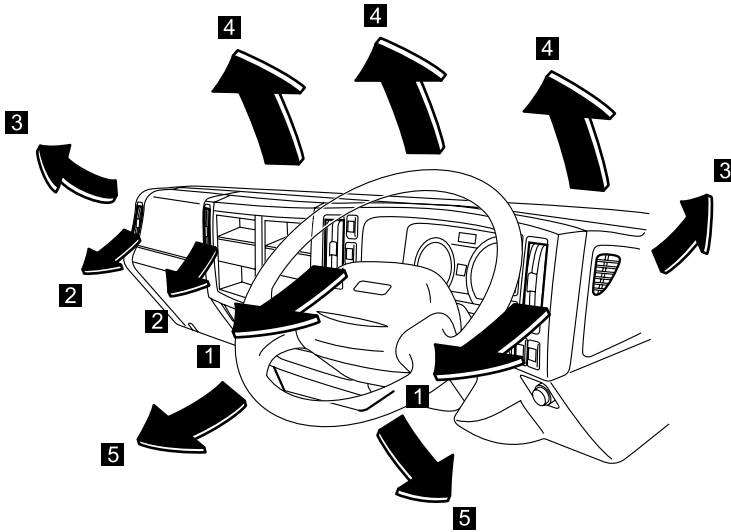

No.	Outlet	Features
1	Driver side outlet	Air flow direction is adjustable with the tab.
2	Passenger side outlet	Air flow direction is adjustable with the tab.
3	Door windows outlet	Air is delivered towards the door windows.
4	Windshield outlet	Air is delivered towards the windshield.
5	Foot outlet	Air is delivered towards the feet.

Air Flow Direction Control Lever

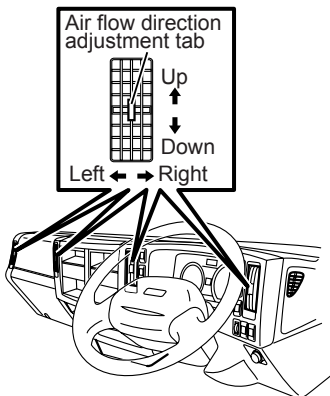

Use the tab to adjust the airflow direction from the outlet. To close the outlet, move the tab fully down.

Ventilator

How to Use the Controls

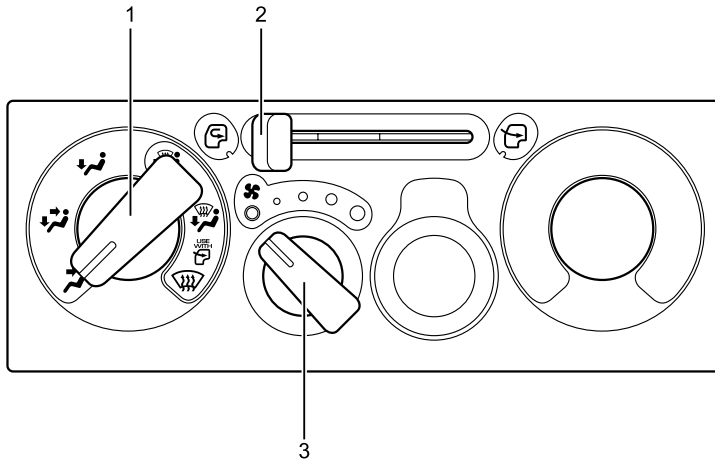

No.	Name
1	Outlet selector knob
2	Air selector lever

No.	Name
3	Fan speed control knob

1. Outlet selector knob

Knob position	Air delivery	Outlet
	Face	Air flows through outlets 1 and 2.
	Bi-level	Air flows through outlets 1, 2 and 5.
	Feet	Air flows through outlets 5.
	Feet, door windows and windshield	Air flows through outlets 5 and some through outlets 3 and 4.
	Feet, door windows and windshield	Air flows through outlets 5 and air of a greater volume than in position "
	Door windows and windshield	Air flows through outlets 3 and 4.

**NOTE**

- The "☰" sign advises you to place the air selector lever in the outside air ventilation position when using the "☰", "☱", "☲" position to defog the windshield.

2. Air selector lever

Lever position	Purpose	
	Outside air ventilation	Use this position to ventilate the cab's interior. (This position should be normally selected.)
	Inside air recirculation	Use this position to prevent dusty or otherwise contaminated outside air from entering the cab (such as in a tunnel or in congested traffic).

**NOTE**

- Extended use of the inside air recirculation position causes the windshield and windows to fog up easily, making visibility poor.

3. Fan speed control knob

The fan speed can be adjusted to any of the 4 speeds available.

Ventilation

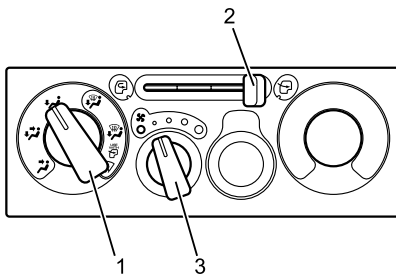
**Outside Air Ventilation**

Turn the outlet selector knob (1) to the preferred position. Move the air selector lever (2) to the "☰" position.

Adjust the fan speed control knob (3) to the preferred speed.

Heater/Manual Air Conditioner V

How to Use the Controls

Model without air conditioner

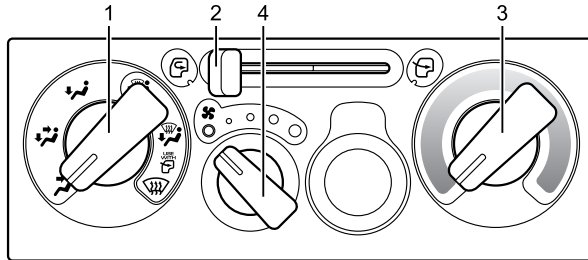

Model with air conditioner

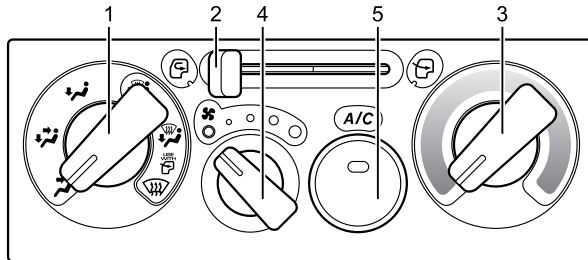

No.	Name
1	Outlet selector knob
2	Air selector lever
3	Temperature control knob

No.	Name
4	Fan speed control knob
5	Air conditioning switch (A/C)

1. Outlet selector knob

Knob position	Air delivery	Outlet
	Face	Air flows through outlets 1 and 2.
	Bi-level	Air flows through outlets 1, 2 and 5.
	Feet	Air flows through outlets 5.
	Feet and defroster 1	Air flows through outlets 5 and some through outlets 3 and 4.
	Feet and defroster 2	Air flows through outlets 5 and air of a greater volume than in position " " flows through outlets 3 and 4.
	Defroster	Air flows through outlets 3 and 4.

**NOTE**

- The "☞" sign advises you to place the air selector lever in the outside air ventilation position when using the "☞", "☞", "☞" position to defog the windshield.

2. Air selector lever

Lever position	Purpose	
	Outside air ventilation	Use this position to ventilate the cab's interior. (This position should be normally selected.)
	Inside air recirculation	Use this position to prevent dusty or otherwise contaminated outside air from entering the cab (such as in a tunnel or in congested traffic).

**NOTE**

- Extended use of the inside air recirculation position causes the windshield and windows to fog up easily, making visibility poor.

3. Temperature control knob

Use this knob to select the preferred cab interior temperature. Turn the knob counterclockwise to lower the outlet air temperature and clockwise to raise it.

4. Fan speed control knob

The fan speed can be adjusted to any of the 4 speeds available.

5. Air conditioning switch (A/C)

Press this switch to use the air conditioning system. The indicator light inside the switch will come on to show that the air conditioning system is in operation. The air conditioning system can also be used for dehumidifying while the heater is being used.

**NOTE**

- Even if the A/C switch is turned on, the air conditioning system will not operate when the fan speed control knob is placed in the stop position. Make sure that the fan speed control knob is in a position other than the stop position.
- Even in seasons when the air conditioning system is not used, occasionally operate the system for a few minutes with the engine running at a low speed in order to keep the system's components lubricated.

Ventilation

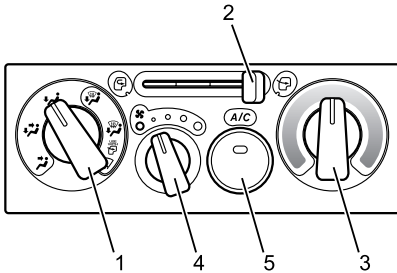

Outside Air Ventilation

Press the A/C switch (5) to the "OFF" position. Turn the outlet selector knob (1) to the preferred position. Move the air selector lever (2) to the "☒" position. Set the temperature control knob (3) to the desired position.

Adjust the fan speed control knob (4) to the preferred speed.

How to Use the Heater

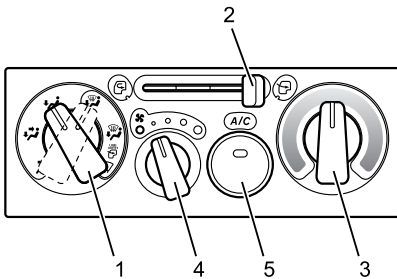

Normal Heating

Set the outlet selector knob (1) to the "☒" or "☒☒" "☒☒☒" position. Use the "☒☒☒" position for warming your feet while defogging the windshield.

Set the air selector lever (2) to the "☒" position.

Adjust the temperature control knob (3) and the fan speed control knob (4) to the desired positions.

To dehumidify the cab interior while heating, press the A/C switch (5) to the "ON" position.

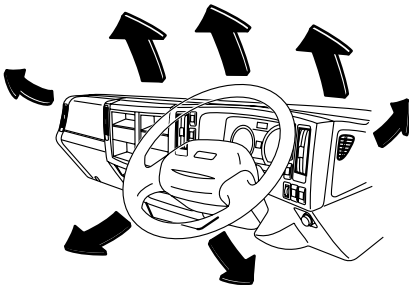

NOTE

- As the heater uses the heat from the engine coolant, its heating effect is weak when the coolant temperature is low. Turn on the warm-up switch to increase the heat.

Warm-Up Switch

→ Refer to page 4-63

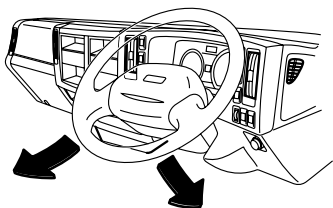
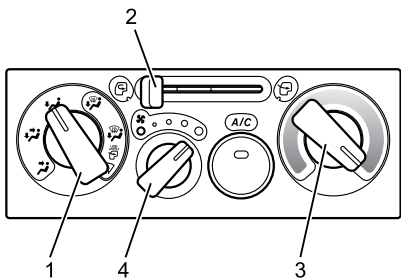

Maximum Heating

Turn the outlet selector knob (1) to the "↔" position, set the air selector lever (2) to the "☑" position, and turn the temperature control knob (3) fully towards the high temperature direction.

Set the fan speed control knob (4) to the maximum speed position.

Turn on the warm-up switch if equipped.

Warm-Up Switch

→ Refer to page 4-63



NOTE

- Extended use of the inside air recirculation position causes the windshield and windows to fog up easily, making visibility poor.

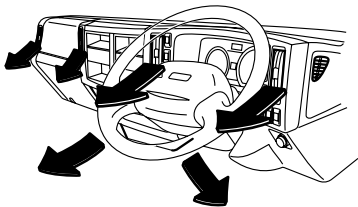
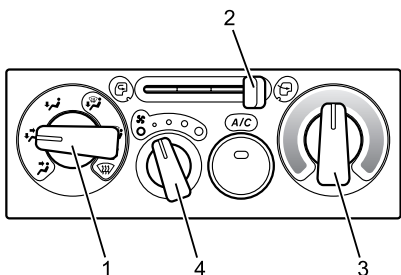

Bi-level Heating

Set the outlet selector knob (1) to the "↔" position.

Set the air selector lever (2) to the "☑" position.

Set the temperature control knob (3) to the middle position.

Adjust the fan speed control knob (4) as desired.

Defogging and Defrosting the Windshield

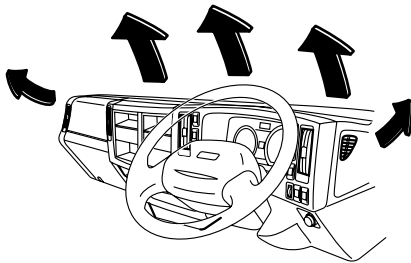
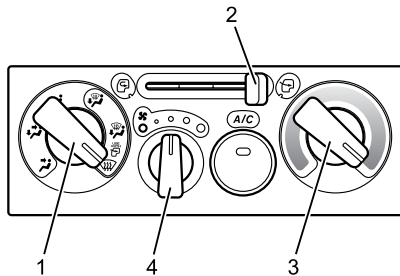

Defogging

Set the outlet selector knob (1) to the "☰" position.

Set the air selector lever (2) to the "☒" position.

Turn the temperature control knob (3) to a high-temperature position according to your preference. For defogging in the summer months, set the temperature control knob (3) to any desired position.

Set the fan speed control knob (4) to any speed position (not the OFF position).

If your vehicle is equipped with an air conditioning system, using the dehumidifying effect of the system is very effective for defogging.



NOTE

- Do not use the maximum cooling position when operating the air conditioning system with the outlet selector knob (1) set to the "☰" position. The outside surface of the windshield will get foggy, impeding forward visibility.

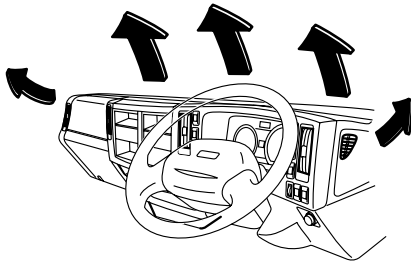
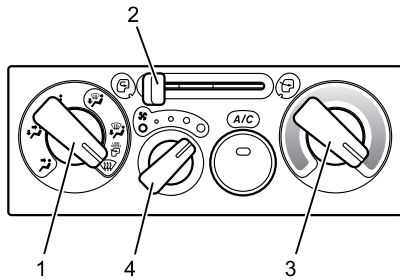

Defrosting

Set the outlet selector knob (1) to the "☐" position.

Set the air selector lever (2) to the "☐" position.

Turn the temperature control knob (3) fully towards the high-temperature direction.

Set the fan speed control knob (4) to the maximum speed position.

Turn on the warm-up switch if equipped.

Warm-Up Switch

→ Refer to page 4-63



NOTE

- After defrosting, be certain to return the air selector lever to the "☐" position. Failure to do so will cause the windshield to fog up, impeding forward visibility.

Cooling

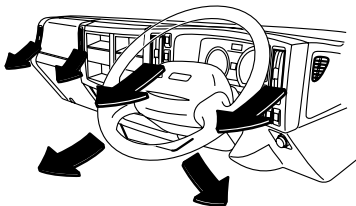
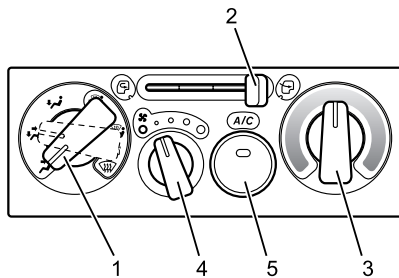

Normal/Moderate Cooling

This setting is suitable for extended periods of cooling or moderate cooling.

Press the A/C switch (5) to the "ON" position.

Set the outlet selector knob (1) to the "☐" position for normal cooling or set it to the "☐" position for moderate cooling.

Adjust the temperature control knob (3) to the desired position.

Adjust the fan speed control knob (4) as desired.



NOTE

- When using the air conditioning system with the engine idling in extremely hot weather, place the air selector lever (2) in the "☐" position.

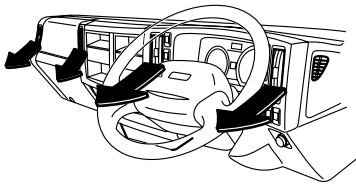
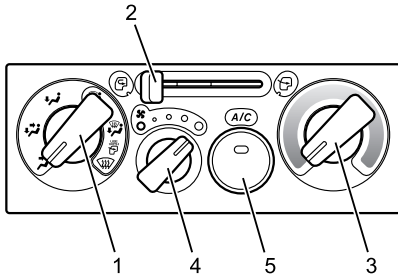

Maximum Cooling

Set the outlet selector knob (1) to the "↗" position.

Press the A/C switch (5) to the "ON" position.

Move the air selector lever (2) to the "↖" position.

Turn the temperature control knob (3) fully towards the low-temperature direction.

Set the fan speed control knob (4) to the maximum speed position.



NOTE

- After prolonged parking in direct sunlight, open the windows or doors to ventilate the cab's interior and release the heat before turning the air conditioning system on.
- Prolonged use of the air conditioning system in the maximum cooling setting will make the interior air become stale. Occasionally move the air selector lever to the outside air introduction position or open the windows to allow fresh air into the cab.
- During cooling operation, mist may come out of the air outlets. This results from quick cooling of humid air, and does not indicate any problem.

Automatic Air Conditioner v

How to Use the Controls

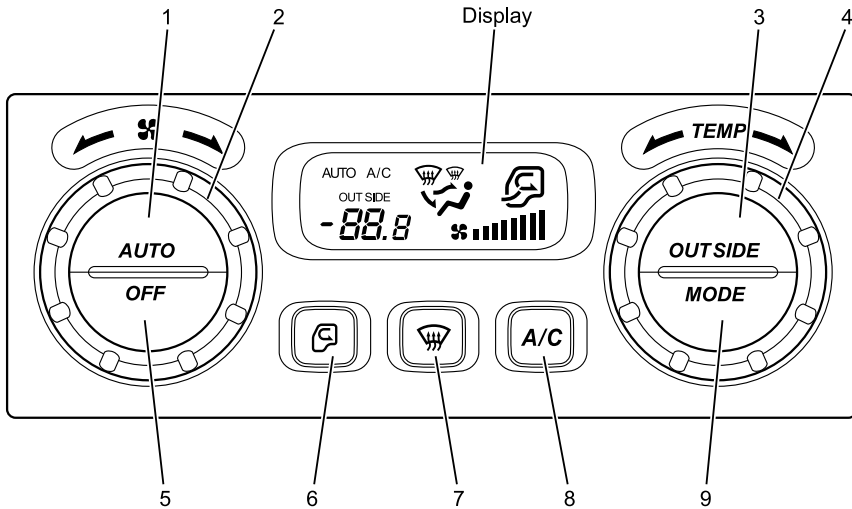

No.	Name
1	Automatic air conditioning switch (AUTO switch)
2	Fan speed control dial
3	Outside air temperature display switch (OUTSIDE switch)
4	Temperature control dial

No.	Name
5	Automatic air conditioning off switch (OFF switch)
6	Air selector switch
7	Defroster switch
8	Air conditioning switch (A/C)
9	Outlet selector switch (MODE switch)

1. Automatic air conditioning switch (AUTO switch)





Press this switch to use the air conditioning system in the fully automatic mode. When the switch is pressed, the system automatically selects the most suitable air outlets, fan speed and all other air conditioning parameters.

**NOTE**

- The last setting has priority over the previous setting for every control.

2. Fan speed control dial

Use this dial when manually selecting the fan speed. Turning the dial counterclockwise reduces the fan speed and turning it clockwise increases the fan speed. The fan speed can be adjusted through 8 levels.

Fan speed	Low	Medium	Fast	Maximum
Displayed symbol				



NOTE

- Even in seasons when the air conditioning system is not used, occasionally operate the system for a few minutes with the engine running at a low speed in order to keep the system's components lubricated.

3. Outside air temperature display switch (OUTSIDE switch)

Use this switch to check the outside air temperature. Each time the switch is pressed, the display toggles between the outside air temperature and the interior temperature now selected.



NOTE

- The control unit of the automatic air conditioner makes necessary corrections before it shows the outside temperature on the display. However, a temperature higher than the actual outside air temperature may be displayed under the following conditions.
 - The traffic is congested or the vehicle is stationary with the engine running.
 - The vehicle is operating under strong sunlight and the road reflects heat of the sun.
 - There are quick changes in temperature.

4. Temperature control dial

Use the temperature control dial for setting the desired interior temperature. The display will show the set temperature. Each turn by one notch makes a change of 0.5°C (0.9°F). The adjustable temperature range is between 18°C (64°F) and 32°C (90°F).



If you set the temperature at 18°C (64°F), the system invariably sets the control for maximum cooling; if you set it at 32°C (90°F), the system sets the control for maximum heating.

5. Automatic air conditioning off switch (OFF switch)

Press this switch to stop both the fan and air conditioning.

6. Air selector switch



Use this switch to change between ventilation of outside air and recirculation of the interior air. The display will show the setting you have made by the corresponding symbol as follows.

Displayed symbol	Purpose	
	Outside air ventilation	This setting should normally be selected. (Use this setting to ventilate cab interior).
	Inside air recirculation	Use this position to prevent dusty or otherwise contaminated outside air from entering the cab (such as in a tunnel or in congested traffic).

**NOTE**

- Extended use of the inside air recirculation position causes the windshield and windows to fog up easily, making visibility poor.

7. Defroster switch

Use this switch for defogging or defrosting the windshield. Pressing the switch causes the display to show the "". Pressing the switch again will return the display to the setting previous to "".







Displayed symbol	Purpose	Outlet
	Defroster	Air flows through outlets 3 and 4.

8. Air conditioning switch (A/C switch)

Use this switch to turn the air conditioning on or off. If the A/C switch is pressed during fully automatic mode operation, the "AUTO" and "A/C" indications will disappear from the display. Pressing it again will cause the system to return to the fully automatic mode.

9. Outlet selector switch (MODE switch)

The air outlet will change each time you press this switch. The outlet now selected will be shown on the display.

Displayed symbol	Air delivery	Outlet
	Face	Air flows through outlets 1 and 2.
	Bi-level	Air flows through outlets 1, 2 and 5.
	Feet	Air flows through outlets 5.
	Feet and defroster 1	Air flows through outlets 5 and some through outlets 3 and 4.
	Feet and defroster 2	Air flows through outlets 5 and air of a greater volume than in position "  " flows through outlets 3 and 4.

Automatic Air Conditioning Mode

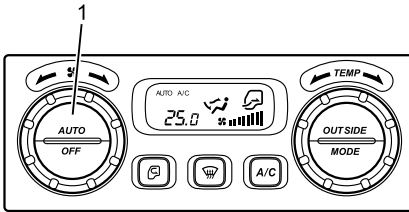

1. Press the AUTO switch (1). The air conditioning system will turn on, and automatically select the air outlets and fan speed most suitable for the cab's interior condition. The selected air outlets will be those corresponding to either the "↖↗", "↖↘" or "↗↘" mode. The display will then show "AUTO A/C".

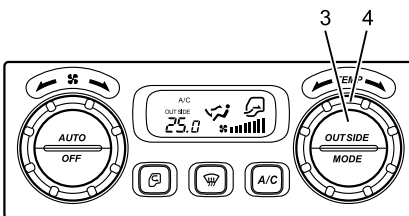

2. Use the temperature control dial (4) to set the interior temperature to the preferred level. The display will show the set temperature. Each turn by one notch makes a change of 0.5°C (0.9°F). The adjustable temperature range is between 18°C (64°F) and 32°C (90°F). If you set the temperature at 18°C (64°F), the system invariably sets the control for maximum cooling; if you set it at 32°C (90°F), the system sets the control for maximum heating. When you press the OUTSIDE switch, "OUTSIDE" will be shown on the display and the outside air temperature will be indicated. Pressing the OUTSIDE switch (3) again will return the display to the set temperature indication.



NOTE

- Although the temperature can be set in the range of 18°C (64°F) to 32°C (90°F), the number displayed shows an approximate temperature. You may thus need finer adjustments for the preferred temperature.
- As the heater uses the heat from the engine coolant, its heating effect is weak when the coolant temperature is low. Turn on the warm-up switch to increase the heat.

Warm-Up Switch

→ Refer to page 4-63

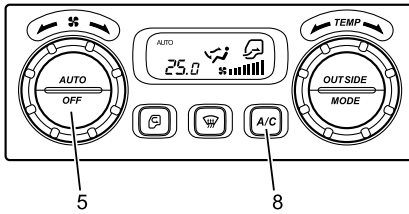

- To turn off the air conditioning system, press the A/C switch (8). To turn off both the fan and air conditioning system, press the OFF switch (5).

**NOTE**

- If you operate a certain control (excluding the temperature control dial) when the system is operating in the fully automatic mode, the "AUTO" indication will disappear from the display and the setting you have made with the control will be shown on the display. Although your preferred setting remains for that particular control where you set it, the system continues automatic control for all other parameters.
- To return to the fully automatic air conditioning mode, press the AUTO switch (1).

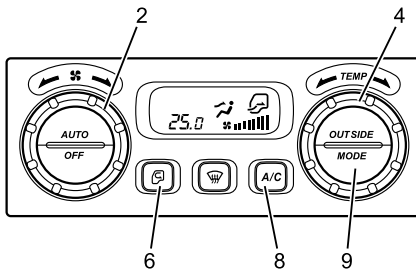
Manual Air Conditioning Mode**Outside Air Ventilation**

Press the A/C switch (8) to turn off the air conditioning system. The "A/C" indication on the display will go out.

Select the desired temperature with the temperature control dial (4) and select the desired air outlets with the MODE switch (9).

Press the air selector switch (6). The display will show the "🌀" sign. Adjust the fan speed with the fan speed control dial (2) as desired.

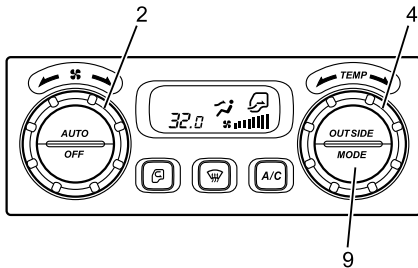

Maximum Heating

Turn the temperature control dial (4) to the maximum heating temperature (32°C (90° F)) and set the fan speed control dial (2) for the maximum setting. Select the desired air outlets with the MODE switch (9).

Turn on the warm-up switch if necessary.

Warm-Up Switch

→ Refer to page 4-63

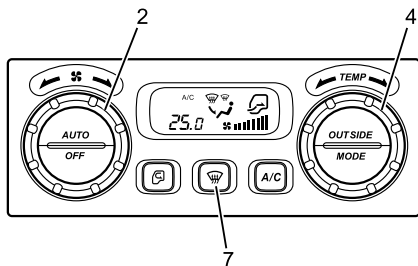
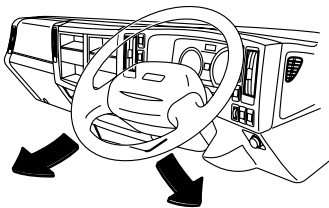

Defogging

Press the defroster switch (7) to turn the defroster on. The display will show the "☀" sign and the air conditioning system starts operating.

Turn the temperature control dial (4) to the desired setting.

Turn the fan speed control dial (2) to the desired setting. The efficiency of defogging will be lower when the display is showing the "☁" sign (inside air recirculation) than when it is showing the "☀" sign (outside air ventilation).

Press the MODE switch to select the desired air outlets. If you press the switch so that the "☀" or "☀" sign appears on the display, you can defog the windshield while warming your feet as well.

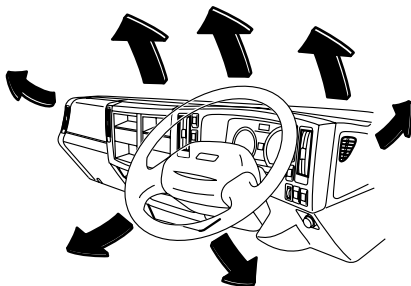

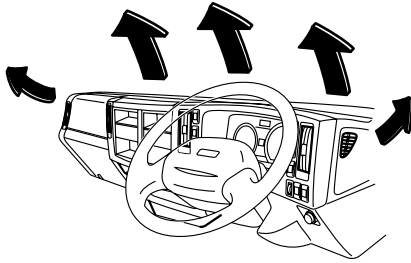
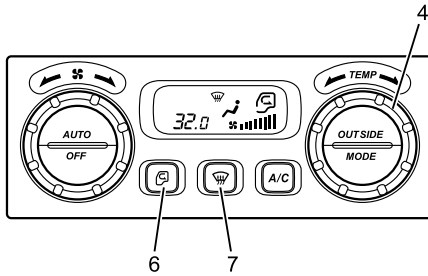

Defrosting

Press defroster switch (7) to turn the defroster on. The display will show the "☸" sign. Turn the temperature control dial (4) to the maximum temperature position (32°C (90°F)).

Press the air selector switch (6). The display will show the "☸" sign. Turn on the warm-up switch.

Warm-Up Switch

→ Refer to page 4-63



CAUTION

- After defrosting, make sure to press the air selector switch so that the "☸" sign (outside air introduction) will be shown on the display.
- Failure to do so will cause the windshield to fog up, deteriorating forward visibility.

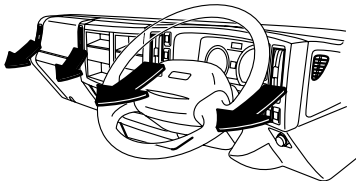
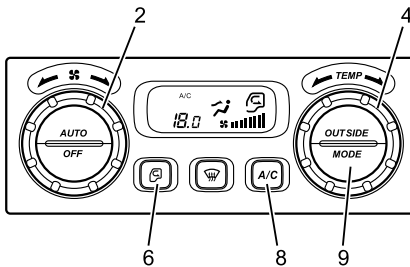

Maximum Cooling

Turn the temperature control dial (4) to the maximum cooling position (18°C (64 °F)) and turn the fan speed control dial (2) to the highest speed setting. Select the desired air outlets with the MODE switch (9) and press the air selector switch (6). Make sure the display is then showing the "☸" sign (inside air recirculation).

You must press the A/C switch (8) before doing the above operation to turn the air conditioning system on.

**NOTE**

- After prolonged parking in the direct sunlight, open the windows or doors to ventilate the cab's interior and release the heat before turning the air conditioning system on.
- Prolonged use of the air conditioning system in the maximum cooling setting will make the interior air become stale. Occasionally press the air selector switch to make the outside air introduction sign appear on the display or open the windows to allow fresh air into the cab.
- During cooling operation, mist may come out of the air outlets. This results from quick cooling of humid air, and does not indicate any problem.

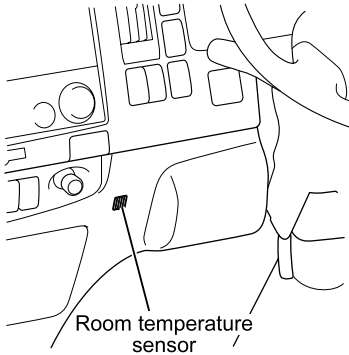
Temperature Sensors

The air conditioning system uses a sun sensor, room temperature sensor and outside air temperature sensor to ensure effective and comfortable air conditioning. Do not place anything on the sensors or get them wet. Air conditioning control will become inaccurate.

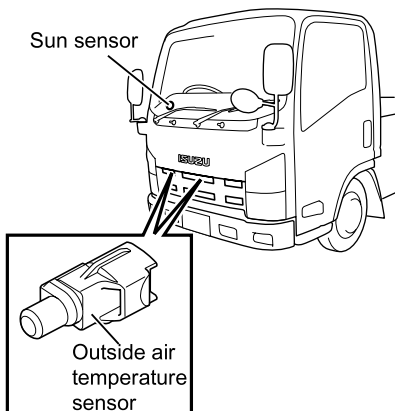

Interior Lights

Dome Light

NLR/NNR/NPR/NQR/NPS models

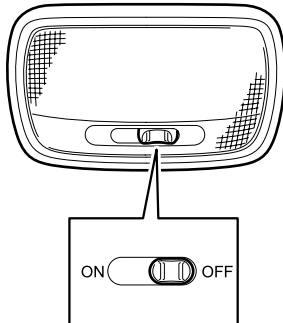

The dome light operates regardless of the starter switch position. To make the dome light be controlled by the "DOOR" operation, move the dome light switch in half way between the "ON" and "OFF" positions.

ON : The light stays on regardless of the doors being open or closed.

DOOR : The light turns on when any of the doors are opened, the doors are unlocked with the remote control unit, or the key is removed from the starter switch.

OFF : The light stays off regardless of the doors being open or closed.

Rear Light (Crew Cab Model)

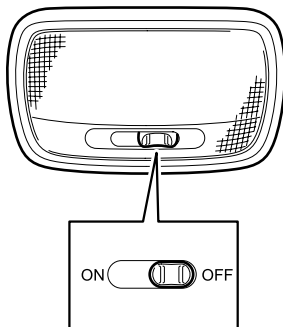

The dome light operates regardless of the starter switch position. To make the dome light be controlled by the "DOOR" operation, move the dome light switch in half way between the "ON" and "OFF" positions.

ON : The light stays on regardless of the doors being open or closed.

DOOR : The light turns on when any of the doors are opened, the doors are unlocked with the remote control unit, or the key is removed from the starter switch.

OFF : The light stays off.

Sun Visor

Driver's side

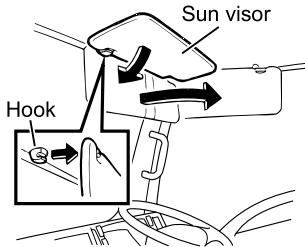

The sun visor protects your eyes in strong sunlight. Use it when sunlight is too bright. To reduce side glare, unhook the sun visor and swing it around to the side.



CAUTION

- For safety, make sure to fold up the sun visor after use.

Passenger's side (model with passenger's side sun visor only)

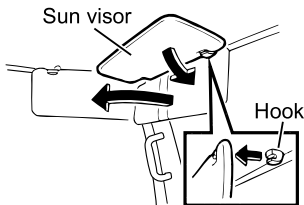

Cigarette Lighter

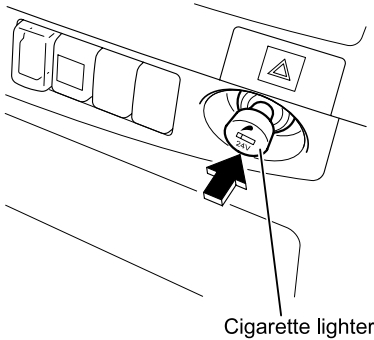

The cigarette lighter can be used when the starter switch is in the "ACC" or "ON" position.

1. Push the lighter in until it locks.
2. When the heater element becomes hot, the lighter pops out to the original position. Pull out and use it.

WARNING

- As the lighter's tip can become extremely hot, take due precautions against burns.
- Do not leave your finger on the cigarette lighter once it has been pushed in. The lighter will overheat and be damaged or cause a fire.
- If the cigarette lighter does not pop out after more than 20 seconds, the lighter is defective. Pull out the lighter by hand immediately.
- Do not leave the vehicle with the cigarette lighter pushed in. This could cause a fire.
- As there is a burn hazard, do not touch the heater element when using the cigarette lighter.
- Do not bend the cigarette lighter. A bent lighter does not function properly and is dangerous.

CAUTION

- Check with your Isuzu Dealer if you have no alternative to using the cigarette lighter socket as an accessory outlet.
- If the cigarette lighter has to be replaced, use an Isuzu genuine replacement. Do not use other cigarette lighters.
- When cleaning the cigarette lighter, do not use too much force. It may become bent.
- Keep the cigarette lighter socket and the heater free of ash and dirt.

**ADVICE**

- Do not use the cigarette lighter while the engine is not running. The cigarette lighter consumes a lot of electricity and could discharge the battery completely.

Ashtray **WARNING**

- Do not put any paper trash or other flammable material in the ashtray.
- After using the ashtray, be sure to close it. If a cigarette butt has not been extinguished completely, other butts in the ashtray may catch fire.
- Do not leave the ashtray full of cigarette butts.
- Put matches and cigarette butts in the ashtray only after they are fully extinguished.

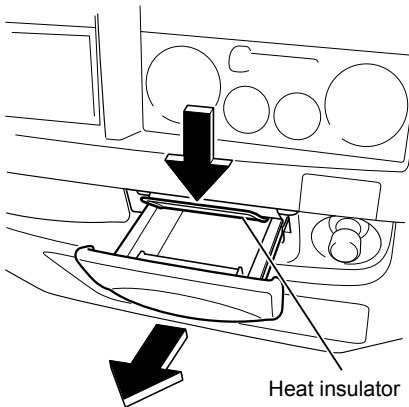
Ashtray under Centre of Dashboard (NHR Model)

Pull the ashtray towards you to use it.
Put out lit cigarettes on the crush-out tab.
You can remove the ashtray for cleaning by holding down the heat insulator and pulling the ashtray toward you.

Driver's and Passenger's Ashtray (NLR/NNR/NPR/NQR/NPS Models)

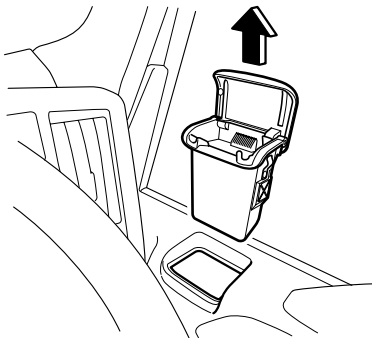

Open the lid to use.

Put out lit cigarettes on the crush-out tab.

To empty the ashtray, hold the lid and pull the ashtray up and out.

Rear Ashtray (Crew Cab Model)

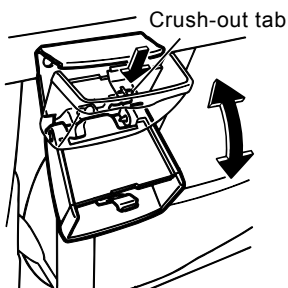

Pull the ashtray towards you to use it.

Pull out lit cigarettes on the crush-out tab.

The ashtray cannot be removed. To empty the ashtray, turn it down while pushing the crush-out tab to remove cigarette butts into an appropriate container.

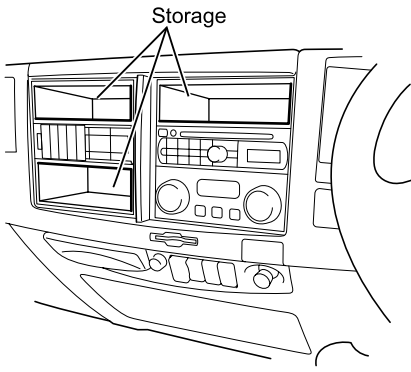
Small Article Storage Pocket 

Use them for storing small articles.

**CAUTION**

- Do not leave eyeglasses or lighters inside the cab. Lighters may explode and plastic lenses or frames may deform or crack if the interior temperature becomes very hot.

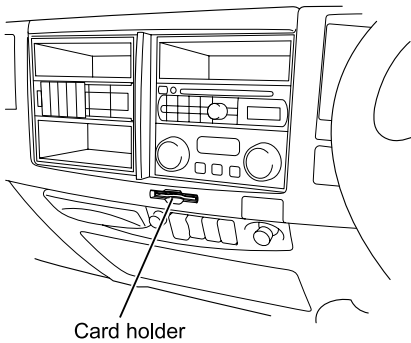
Card Holder

Use this to hold your cards.

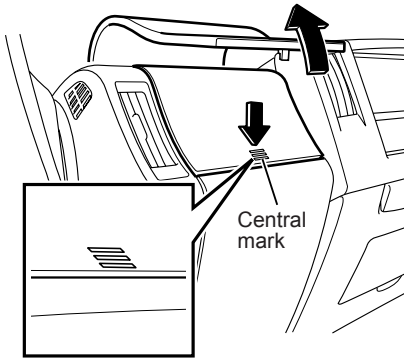

Glove Compartment 

Press on the central mark to lock and unlock the lid.

CAUTION

- For safety, close the glove compartment during driving. There is a risk of injury from the open lid or items stored in the glove box.
- The glove box lid will automatically spring open when it is unlocked. Do not put your face or head near the lid.
- Do not leave eyeglasses or a lighter in the vehicle. Lighters may explode and plastic lenses or frames may deform or crack if the interior temperature becomes very hot.

**ADVICE**

- Do not place an object in the glove compartment that is so large that the lid of the compartment cannot be closed. If you attempt to close the lid in this condition, you are likely to break the lid of the glove compartment.

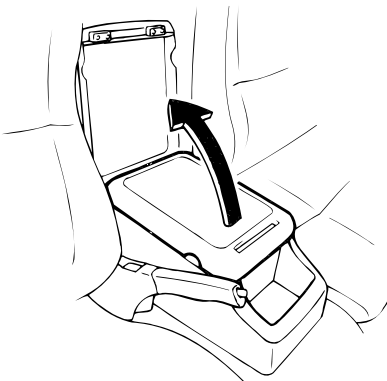
Centre Console Box 

Pull up the lid to open the centre console.

CAUTION

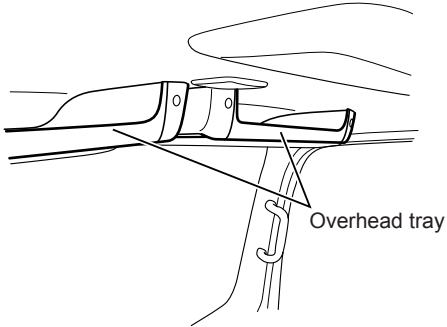

- Do not leave eyeglasses or lighters inside the cab. Lighters may explode and plastic lenses or frames may deform or crack if the interior temperature becomes very hot.

Overhead Tray 

Use the overhead trays as shelves.

**CAUTION**

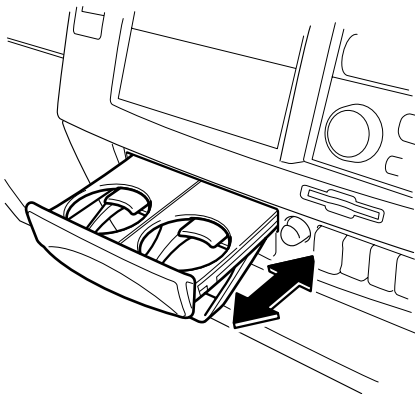
- Do not use either overhead tray to hold an object weighing more than 2 kg (71 oz) or an object that may fly out or fall down during vehicle operation. Doing so would be dangerous.
- Items may fly out or fall down when the cab is lowered after being tilted.
- Do not leave eyeglasses or a lighter in the vehicle. If the cab became hot, a lighter left there could explode and plastic eyeglass lenses or frames could deform or crack.

Cup Holder 

Pull towards you to open.

**CAUTION**

- Do not place a cup that is too full in the cup holder. Spillages could cause damage to the radio and other electrical circuits. If there is a spill, wipe it up immediately with a dry cloth.
- Do not tilt the cab with a filled cup in the cup holder. There may be a danger of the cup holder breaking if the weight on each holder exceeds 0.75 kg (26 oz).

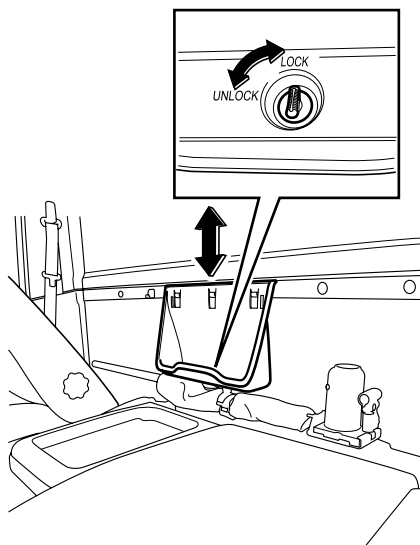
Back Panel Tray (Storage Receptacle) v

Use them for storing small articles. They can be removed.

Installation and Removal

1. Turn the knob to the "UNLOCK" position.
2. Lift the back panel tray upward to remove it from the three tabs.
To install the back panel tray, perform this action in reverse. After installing the back panel tray, turn the knob to the "LOCK" position.

**CAUTION**

- Do not use the back panel tray to hold any object weighing more than 2 kg (71 oz) or an object that may fly or fall out during vehicle operation. Doing so would be dangerous.
- Items may fly or fall out when the cab is tilted.
- Do not leave eyeglasses or a lighter in the vehicle. If the cab became hot, a lighter left there could explode and plastic eyeglass lenses or frames could deform or crack.

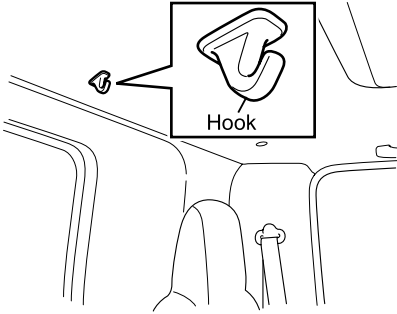
Coat Hook v

Use this to hang clothing.

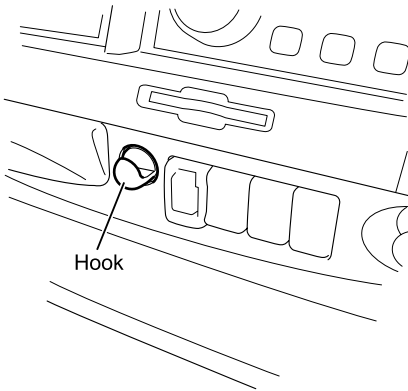
Hook

This can be used to hold plastic shopping bags.

**CAUTION**

- Do not hang anything weighing over 3 kg (106 oz) or that may fall off the hook while driving. Doing so may be dangerous.

Operating Tips for the Radio and CD Player



CAUTION

- Operate the radio or CD player only while the vehicle is stationary. Operating them while the vehicle is moving could cause an accident.
- Adjust the volume so that sound outside of the vehicle can be heard. If outside sound cannot be heard, accidents may be harder to avoid.
- Do not install a radio equipment antenna near the vehicle's radio antenna. This could cause unwanted noise on the radio or while playing a CD.

Operating the CD Player

Only CDs with  mark can be used.



ADVICE

- On cold or rainy days, condensation may form in the CD player preventing normal operation. If this occurs, eject the CD and use the air conditioning system to dehumidify or ventilate the cab interior for a while before reinserting the CD.
- Rough road driving with severe vibrations may cause the CD to skip.
- Using benzene, record disk cleaner or anti-static fluids may damage the CD. If a CD is dirty, wipe it with a soft cloth moistened with water to remove dirt and then wipe it again with a dry cloth to remove all the moisture. Wipe the CD from the centre to the edge.
- CDs are easily damaged by heat, so do not place them in direct sunlight or near an air outlet during heating.

Antenna

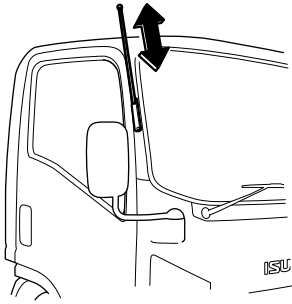

Pull the antenna out to its full length when using it.



ADVICE

- To prevent breaking the antenna, shorten it when passing through areas with low clearance or through a carwash.



NOTE

[Radio reception]

- Compared with AM signals, FM signals are of better quality and compatible with stereo broadcasting. However, due to the nature of FM signals, conditions in which the quality of signals received in a moving vehicle may not be sustainable.
 - The directness of FM signal transmission
As FM signals are more strongly directional than AM signals, they are blocked easily by large objects such as mountains and buildings and as such their reception area is much narrower than AM signals.
 - Sound loss
FM signals are reflected easily by objects, so when driving through built-up areas, the sound may be interrupted or disturbed by noise.
 - Sound distortion
Simultaneous reception of direct signals from the radio station and reflected signals from buildings may cause flutter or noise disturbance.



TIPS ON SAFE AND SMOOTH OPERATION

6

• Driving Safely and with Confidence	6-2
• On the Road	6-3
• Cautions for Parking	6-15
• Cautions for Driving in Hot Regions	6-16
• Cautions for Driving in Cold Regions	6-17
• Using Tyre Chains	6-22

Driving Safely and with Confidence

Get Plenty of Rest



If you drive when you are tired, you will get sleepy and lose concentration. Please get plenty of rest before you drive.

Take Breaks during Long Journeys

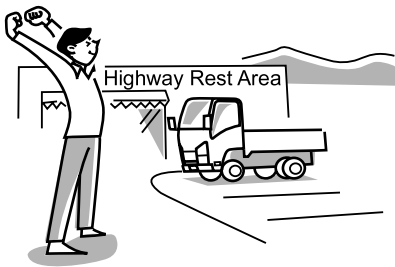

Driving long distances is tiring. Please take rest breaks from time to time.

On the Road

Cautions for Driving

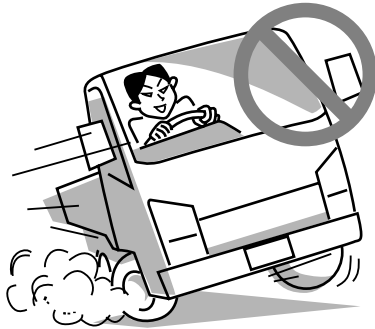

- Concentrate on driving safely, obeying all legally designated speed limits, road signs and traffic signals.
- Do not place the starter switch to any position other than the "ON" position while driving. The power steering would stop working, making steering extremely difficult. Also, the brakes would not work well, putting you in extreme danger.
- If you notice any abnormal noise, abnormal smell or abnormal vibration from any part of the vehicle, immediately stop the vehicle in a safe place and perform checks.
- If a warning light comes on or a buzzer sounds while you are driving, immediately stop the vehicle in a safe place and perform checks.
- Do not put your foot on the clutch pedal except when using the gearshift lever. Doing so would cause premature clutch wear.
- Slow down sufficiently when approaching a curve. Applying the brakes or sharply turning the steering wheel while turning the curve could cause the cargo to shift, the tyres to slip and the vehicle to tip onto its side.
- While driving, do not place your hand on the gearshift lever except when changing gears. Doing so could cause the transmission to fail.
- Avoid scraping the tyre sidewalls against curbstones or driving over dips and protrusions in the road surface.
You could damage the tyres, resulting in a blowout or flat tyre.

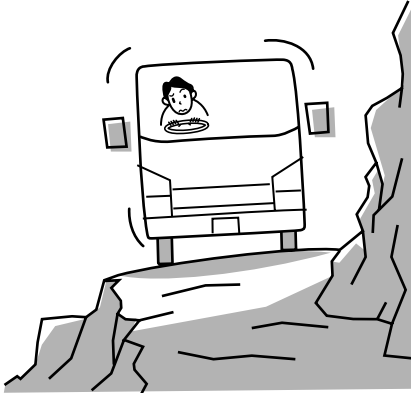
**Narrow or Congested Roads**

When passing or overtaking a vehicle on a narrow mountain road or on a narrow or congested urban road, pay careful attention to obstacles on either side and to the condition of the shoulder of the road.

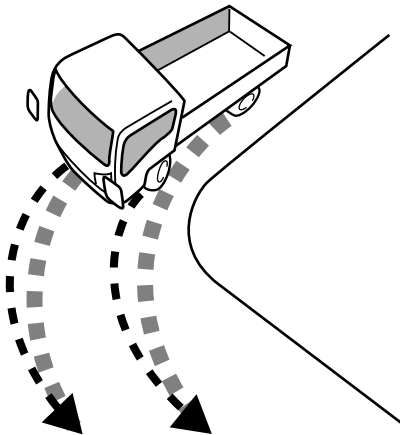
**When Turning, the Rear Wheels will Follow Tighter Curves than the Front Wheels**

Use the mirrors to confirm safety.

Driving Uphill or Downhill

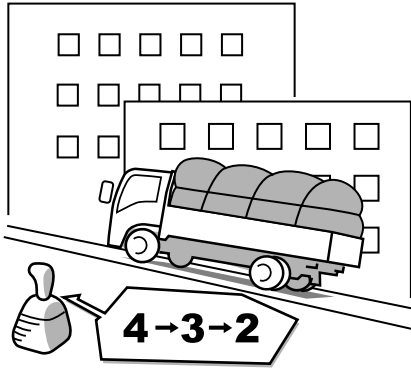

Uphill

Shift down well ahead of time in order to avoid a heavy load to the engine.

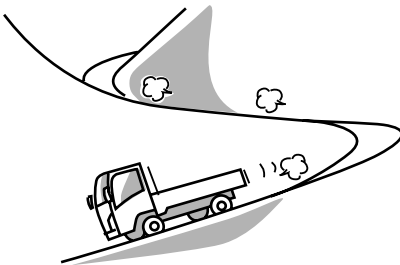

Downhill

- Be careful not to drive too fast on a downhill road.
- Use the same gear(s) that you used to drive up the hill. Also, use the exhaust brake in order to avoid going too fast.
- Do not let the engine overrun.



NOTE

[Overrunning]

- An engine overrun is an engine-speed increase that causes the tachometer needle to enter the red zone. It is dangerous because it can cause engine failure.

Brake Operation

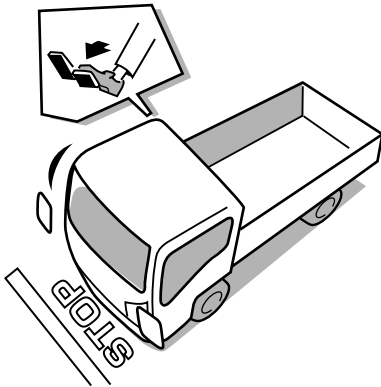
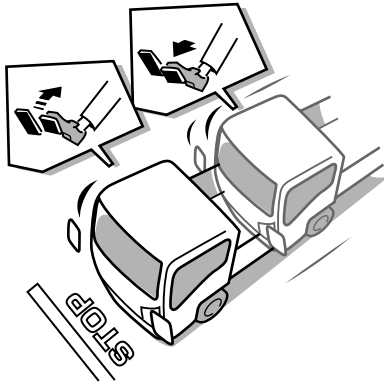

The brakes give strong braking force with only light pressure on the pedal. Do not press the brake pedal hard except in the event of an emergency.

1. Braking distances vary according to the vehicle speed and road conditions. First, slow down sufficiently using the engine brake and the exhaust brake.
2. Press the brake pedal and keep it pressed until just before the point at which you want the vehicle to stop.
3. Ease off the brake pedal.



CAUTION

- Do not allow the brake pedal to fully return. If you allow the brake pedal to fully return, there will be a short delay before the brakes start to work the next time you press the pedal, meaning that the stopping distance may be increased.

4. Immediately before the point where you want the vehicle to stop, gently press the brake pedal to bring the vehicle to a halt.

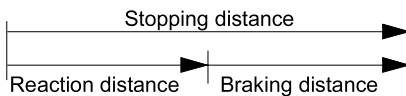

Stopping Distance

The vehicle's stopping distance consists of a reaction distance (from the point where the driver senses danger and presses the pedal to the point where the brakes start to work) and a braking distance (from the point where the brakes start to work to the point where the vehicle comes to a halt). When driving, bear the stopping distance in mind. Maintain a speed and headway distance that allow you to stop safely even if a hazard occurs.

Maintaining a Clear Field of View

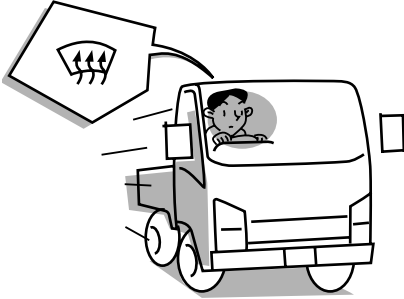

If the Windshield Fogs Up

Use the heater to blow hot air on the windshield or dehumidify the cabin using the air conditioner and place the vent knob in the "☀️" or "❄️" position. Place the inside/outside air selector in the outside-air position. Also, use commercially available antifog spray.

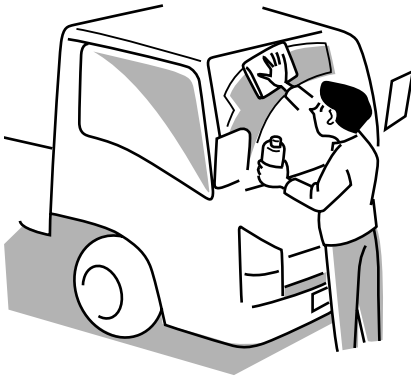

Nighttime Visibility

If there is an oil film on the windshield, the lights of oncoming traffic will be reflected in many directions, making it hard for you to see ahead. Use glass cleaner to clean the glass and the wiper blades.



NOTE

- Worn wiper blades cannot wipe the windshield clean and thus cannot maintain visibility. When the wiper blades become worn, replace them with new ones.

Driving at Night



Nighttime driving is more dangerous than daytime driving because the field of view is narrower. Keep your speed down, and maintain an ample headway distance.

Driving in Fog

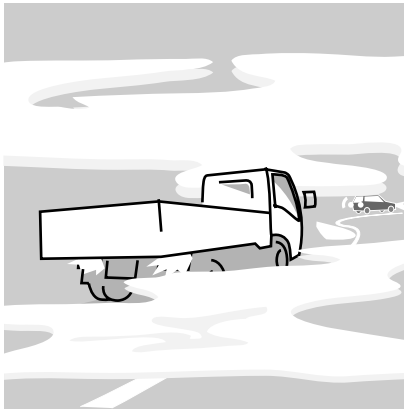

Turn on the fog lights and drive slowly, using the road's center line as a guide. It is dangerous only to follow the lights of the preceding vehicle because they can cause optical illusions. Drive with caution.

Highways

Tyres	<ul style="list-style-type: none"> • Check that there is ample tread depth.
Engine	<ul style="list-style-type: none"> • Check that coolant is not leaking from the radiator and other parts of the cooling system. • Check that the coolant level is high enough. • Check that the fan belt is properly tensioned and free of damage. • Check that the engine oil level is correct.
Fuel tank	<ul style="list-style-type: none"> • Check that the fuel level is high enough.

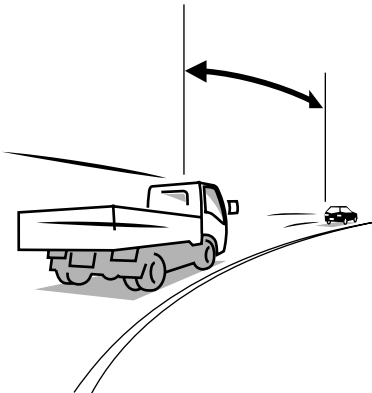
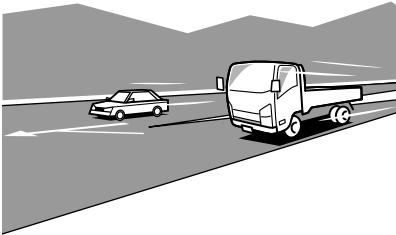

1. Speeds on highways are higher than those on regular roads, so there is more danger. Also, a breakdown on a highway represents a hazard to other vehicles and can cause an accident. Concentrate on safe driving. Remember to perform daily pre-operation inspections and use highway driving techniques. When performing daily pre-operation inspections, perform the checks shown in the table on the left with particularly great care.

Daily Checks (Preoperational Checks)

→ Refer to page 7-16

2. When merging with traffic on a highway, use the turn signal lights to indicate your intentions ahead of time. Speed up sufficiently when you are in the acceleration lane. Pay attention to vehicles behind you and to conditions in the lane you are joining. Merge in such a way that you do not obstruct vehicles in the lane.
3. Your sense of how fast you are traveling becomes distorted on long highway drives. Constantly keep an eye on the speedometer, and maintain a suitable headway distance.



4. During high-speed driving, even a little turn of the steering wheel causes a big movement of the vehicle. Turn the steering wheel slowly.
5. Excessive use of the brake pedal is extremely dangerous because it rapidly wears the brake linings and causes brake fade. Make effective use of the engine brake and the exhaust brake when you wish to decelerate.

**NOTE**

[Brake fade]

- Frequent use of the brakes can cause the brakes to overheat so that the frictional force of the brake linings decreases and the brakes become less effective than normal. This phenomenon is called brake fade.

6. When you wish to turn off a highway, use the turn signal lights to indicate your intentions ahead of time. Paying attention to vehicles behind you, turn off the highway smoothly so as not to obstruct other vehicles.

Driving on Snowy or Frozen Roads

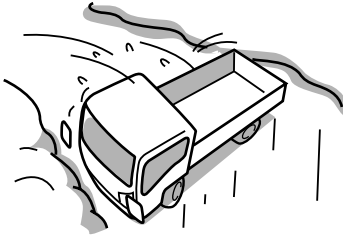

CAUTION

- On slippery roads, never accelerate rapidly, brake hard, decelerate rapidly or make sharp turns of the steering wheel.
- There is a risk of reduced grip between the tyres and road surface and of increased braking distances. The danger of icy road surfaces is particularly great on bridges, in shady places and where there are puddles. Keep your speed down and be sure to use tyre chains or winter tyres on snowy or frozen road surfaces.



ADVICE

- With a AMT vehicle, you can make a standing start in the manual-mode third gear if you first hold down the brake pedal and move the shift lever to the "+" (upshift)" position.

Using Tyre Chains → Refer to page 6-22

Before Driving in Cold Regions

Getting In and Out of the Vehicle

The step can get icy in cold regions. Be careful not to slip when getting in and out of the vehicle.



Before Sitting in the Driver's Seat

Remove snow and ice from your shoes when getting into the vehicle. If you try to drive with snow on your shoes, your shoes would slip on the pedals and you would not be able to press the pedals properly, meaning that your driving would be inconsistent. Also, the cabin could become more humid, causing the glass to fog up.



Starting the Engine

When you start the engine, check that the accelerator pedal works smoothly.

Check the Fuel Level

Fuel consumption becomes higher when tyre chains are used. Check how much fuel you need to reach your destination and top up the tank in advance.

Fuel → Refer to page 6-19

Driving on Snowy or Frozen Roads (Fenders)



Pay Attention to the Way the Steering Wheel Turns and Feels



CAUTION

- On snowy roads, water and snow splashed up by the tyres can freeze and accumulate inside the fenders, making the steering wheel hard to turn. From time to time, get out of the vehicle and remove any accumulated snow. Do not use a sharp implement to remove the snow. Sharp edges could damage rubber parts.



Check the Brakes from Time to Time

CAUTION

- When the vehicle is driven or parked on a snowy surface, ice can form on the brakes, decreasing their effectiveness. From time to time while you are driving, press the brake pedal lightly and check the brake's effectiveness. Pay attention to vehicles both ahead and behind you when checking the brakes in this way.
- Also, check the brake's effectiveness as soon as possible when starting to drive the vehicle after it has been parked. If the brakes do not work well, drive slowly and gently press the brake pedal several times until the brakes dry out and start working normally.

Removing Snow from the Glass and Underbody

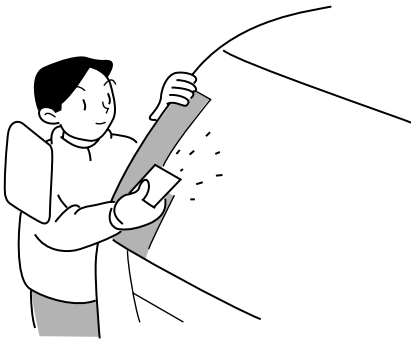

To maintain an adequate field of view, use a plastic scraper to remove snow and frost from the glass surfaces. By using a plastic scraper, you can remove the snow and frost without scratching the glass. At this time, check whether the wiper blades are frozen onto the glass.

Also, look under the vehicle and remove any lumps of ice that are stuck to the underbody. Be careful not to damage components.



ADVICE

- Do not use a sharp implement to remove snow. Sharp edges could damage rubber parts.

Driving on Poor Road Surfaces (Sand or Mud)

If the vehicle gets stuck in mud, pressing the accelerator pedal more than necessary will simply dig the vehicle deeper into the mud and make it harder to extricate. Either put stones, tree branches or blankets under the tyres to gain traction or repeatedly drive forward and backward to use the vehicle's momentum to extricate it.

When you cannot avoid driving through deep mud, using tyre chains is an effective way to avoid getting stuck.

**ADVICE**

- When driving in sand or mud, avoid hard braking, sudden acceleration and sharp turns of the steering wheel. Such actions could get the vehicle stuck and make it impossible to extricate.
- After driving through deep mud, any mud stuck to the vehicle can harm the steering, brakes and powertrain. Wash the vehicle and remove all mud and other incrustation.

Exterior Maintenance

→ Refer to page 7-148

Driving a Four Wheel Drive (4WD) Vehicle**CAUTION**

- 4WD does not make it possible to drive absolutely everywhere. Exercise caution when using the accelerator pedal, steering wheel, and brakes. Concentrate on safe driving, paying attention to the condition and grade of the road surface.

Cautions for Parking

Parking in Cold Regions



When snow collects around the wheels and lights, try to remove it before night falls.

Do not apply the parking brake in cold regions. If you leave the parking brake applied, the wires and brake shoes could freeze up, making it impossible for you to release the parking brake. Be sure to park the vehicle in gear.

To park in gear, place the shift lever in the "1" (first gear) position or "R" (reverse) position and stop the vehicle on a level surface. With a AMT vehicle, make sure the shift indicator is showing "1" or "R" and stop the vehicle on a level surface before stopping the engine.

Be sure to put chocks against the tyres. Whenever possible, park in a garage to help prevent parts from freezing up and to help make the engine easy to start.

Parking in Gear → Refer to page 4-87



CAUTION

- If you park in a place where there is a lot of snowfall, snow accumulating around the vehicle could limit ventilation. Running the engine with the vehicle in these conditions could cause exhaust gases to enter the cabin, resulting in carbon-monoxide poisoning. Take preventive action by, for example, clearing the snow around the vehicle.



NOTE

- When parking outdoors, take steps to prevent the engine from getting unnecessarily cold. For example, position the vehicle with the front end downwind.
- Do not park under trees or under the eaves of a building. Chunks of ice could fall on the vehicle if you park in such a place.
- If you park a hill-start-aid (HSA) model in gear, a warning buzzer will sound for about 30 seconds. This does not indicate an abnormality.

Cautions for Driving in Hot Regions

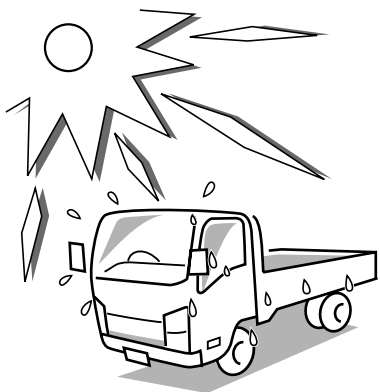

The engine will be prone to overheating in an environment where the ambient temperature is high. To prevent the engine from overheating, pay attention to the following points:



CAUTION

- Do not put well water, river water or other hard water in the engine cooling system. It would hasten the formation of rust and scale.



If foreign matter (insects, mud, etc.) gets stuck in the radiator's air passages, the cooling system's performance will deteriorate. Check the air passages for clogging, and remove any foreign matter using water under low pressure.



ADVICE

- When the ambient temperature is high, evaporation of battery fluid will become quicker. Frequently check the battery fluid level and, when necessary, add more fluid.

Cautions for Driving in Cold Regions



The following cautions apply to snowbound regions and to mountainous regions, ski resorts and other areas of extreme cold and/or snowfall. Please use them also for reference in winter in other regions.

For the sake of your vehicle, have your Isuzu Dealer make the winter preparations described hereafter. Also have these preparations made before driving to a cold region.

Engine Coolant → Refer to page 7-34

Windshield Washer Fluid

→ Refer to page 7-133

Handling the Battery

→ Refer to page 7-138

Engine Oil

→ Refer to page 7-22

Using Tyre Chains

→ Refer to page 6-22

Winter Tyres

→ Refer to page 6-20



CAUTION

- Do not cover the front of the radiator with newspapers, cardboard or any other flammable material to raise the coolant temperature.
- If you allow the engine to warm up but the coolant temperature does not rise, have the nearest Isuzu Dealer inspect the thermostat.
- If you park in a place where there is a lot of snowfall, snow accumulating around the vehicle could limit ventilation. Running the engine with the vehicle in such a situation could cause exhaust gases to enter into the cab, resulting in carbon-monoxide poisoning. Take preventive action by, for example, clearing the snow around the vehicle.

Fuel → Refer to page 6-19

Coolant

To prevent the coolant from freezing and damaging the engine, use a mixture of tap water and engine coolant at a concentration appropriate for the lowest temperature that your vehicle is expected to operate in.

Changing the Engine Coolant

→ Refer to page 7-37

Preparing Coolant

→ Refer to page 7-43

Replacing the Engine Oil

SAE10W-40								
SAE10W-30								
-30	-20	-10	0	10	20	30	40	(°C)
-22	-4	14	32	50	68	86	104	(°F)
AMBIENT TEMPERATURE								

In all seasons, use Isuzu genuine low-ash engine oil.

Changing the Engine Oil and Oil Filter

→ Refer to page 7-28

Recommended Fluids,

Lubricants and Diesel Fuels

→ Refer to page 7-172

Fuel

**CAUTION**

- Always use only a low-sulfur diesel fuel (50 ppm or lower sulfur content) or super-low-sulfur diesel fuel (10 ppm or lower sulfur content). The use of a poor-quality diesel fuel, mixing such an additive as water remover to the fuel in the tank, or filling the tank with gasoline, kerosene or an alcohol-based fuel or its mixture with a diesel fuel will badly affect the fuel filter and result in lubrication problems in fuel-lubricated components of the injectors. In addition, this practice can also impair the operation of the engine and the diesel particulate defuser (DPD), the exhaust emission cleaning system, possibly leading to breakdown of the engine-related systems. If an incorrect fuel should accidentally be added, drain all fuel from the system. Failure to observe this precaution can result in the outbreak of fire or permanent damage when the engine is started.
- The use of any fuel other than a low-sulfur or super-low-sulfur diesel fuel in a DPD-equipped vehicle may violate the relevant regulations enforced in certain countries or regions.
- Open the fuel tank filler cap slowly. If you open it quickly, fuel may spurt out.

If you drive to a cold region in winter while using diesel fuel for warmer regions that freezes at a relatively high temperature, the fuel may freeze. As the ambient temperature decreases, the fuel in the fuel tank and pipes may freeze like slush, making the engine hard to start.

**NOTE**

- The specifications of diesel fuel differ according to the season and region.
- When driving to a cold region, put just enough fuel to reach the destination in the tank. As soon as you reach the cold region, fill the tank with fuel that has a low freezing temperature.
- When taking the vehicle to a cold region on a ferry, board the ferry with only a minimal amount of fuel in the tank and then, after reaching the cold region, fill the tank with fuel that has a low freezing temperature.

When Ice Prevents You from Putting the Key in the Door or Opening the Door

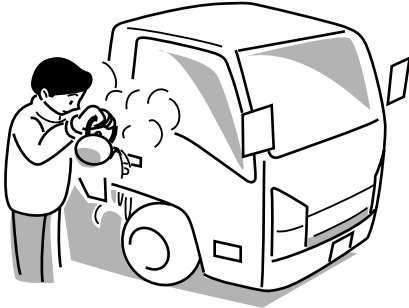

If you try to force the key into the door, you could bend it. And if you try to pull the door open with undue force, the rubber seal around the door could come unstuck or become damaged. Use warm water to melt the ice, then quickly wipe it away and open the door.

If the wipers, electric door mirrors, or power windows freeze up, also use warm water to melt the ice and then operate the system. Otherwise, you could damage the mechanism and drain the battery. After that, wipe the water away.

Winter Tyres

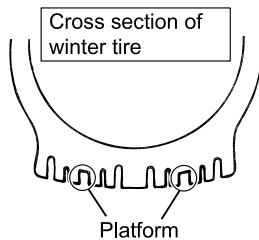

Use winter tyres of the same sizes as the standard tyres. Also, use wheels of the same size as those with the standard tyres.

A winter tyre has reached its wear limit when the tread grooves have worn to half of the depth of the new tyre. At this time, platforms indicating that the tyre can no longer give adequate performance on snow become visible in the grooves. Replace the tyre with a new one.



CAUTION

- Avoid sharp turns of the steering wheel and hard braking. Use the engine brake to decelerate. When applying the brakes on snowy or frozen road, lightly press the pedal several times rather than giving it one hard press. A single hard press of the pedal would be dangerous because it could cause the vehicle to slip or skid.
- If you use the exhaust brake on a slippery road when the vehicle is not loaded, the resulting hard deceleration can cause the back of the vehicle to swing sideways. Exercise caution.
- Avoid driving at high speeds on a dry road with winter tyres.
- Comply with local legal requirements when using winter tyres.

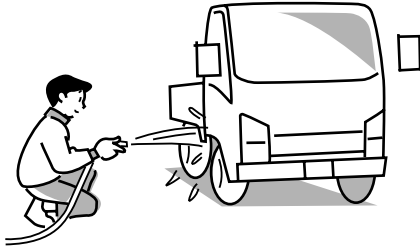
Cleaning the Vehicle after Driving on Snowy Roads**CAUTION**

- Remove snow that has stuck to the inside of the fenders and to the brake hoses. Otherwise, it may damage components. After driving on a salted road, wash the underside of the vehicle as soon as possible to prevent the salt from causing rust. Spraying water under high pressure is an effective way to get the salt off.
- After washing the vehicle, wipe the door openings dry.

**ADVICE**

- On anti-lock brake system (ABS) equipped model, the vehicle speed sensors are fitted on the wheels. When removing snow, ice and other incrustation, take great care not to damage the components.
- Do not use a sharp implement to remove snow. Sharp edges could damage rubber parts.

Anti-lock Brake System (ABS)

→ Refer to page 4-115

Using Tyre Chains

Before the onset of winter, make preparations for use of tyre chains by fitting the tyre chains, adjusting their lengths and checking them for damage.



CAUTION

- Immediately after vehicle operation, the exhaust pipe and muffler are extremely hot. Be careful not to touch them. Also, do not change a tyre while diesel particulate defuser (DPD) regeneration is under way because the exhaust temperature then is very high.
- Be careful not to hurt yourself on the edges of the vehicle while working with the tyre chains.



ADVICE

- Tyre chains cannot be fitted on the front wheels. Fit the rear tyres with chains suitable for the tyre size. For further details, please contact your Isuzu Dealer.
- When the vehicle is fitted with tyre chains, drive at speeds below 30 km/h (19 MPH) and avoid driving on surfaces other than snowy or frozen roads.

How to Fit a Tyre Chain

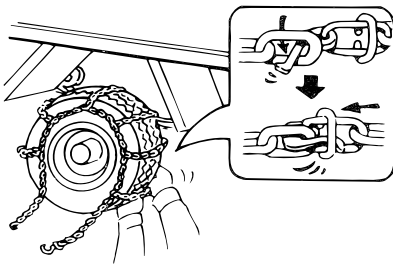
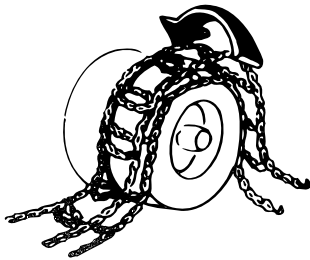
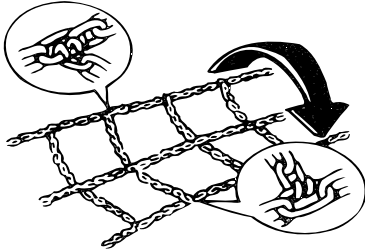
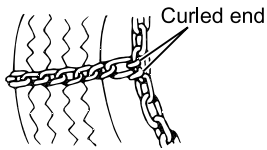

1. Making sure the tyre chain is not twisted, place it on the tyre so that the curled ends are on the outside (the side that will make contact with the ground).



NOTE

- Fold the tyre chain in two and lay it on the tyre closer to you (the outer tyre). Then, unfold the top half of the tyre chain and lay it on the inner tyre.

2. Pull both ends of the tyre chain as far as possible. Couple the inner hooks first, and then couple the outer hooks.



ADVICE

- When you purchase tyre chains, try fitting them on the tyres and, if they are too long, cut them shorter to suit the tyres.



NOTE

- With dual tyres, couple the center hooks, inner hooks, and outer hooks in that order.

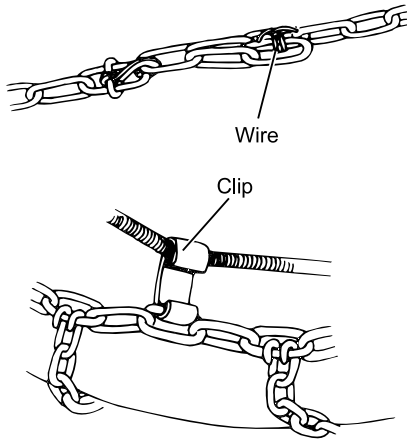

3. Retain any excess portion of chain with wire so it does not hit the vehicle's body or brake pipes.

4. Hook the clips over the chain band (with the clips pointing outward) such that the clips are evenly positioned around the band.

5. After fitting the tyre chains and driving for a while, check whether the chains are loose or they have come unfastened.

How to Remove a Tyre Chain

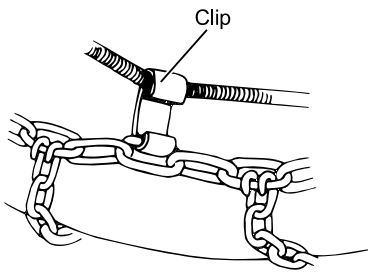

1. Remove the chain band, remove any wire, undo the outer hooks and finally undo the inner hooks.

2. Move the vehicle and remove the chain.



NOTE

- With dual tyres, unfasten the outer hooks, inner hooks, and center hooks in that order.



ADVICE

- If a tyre chain breaks or comes partially unfastened while the vehicle is moving, it will harm the vehicle body. Take corrective action right away.
- If the vehicle has dual tyres, be sure to use tyre chains that are designed for dual tyres.
- If the vehicle has dual tyres, do not fit tyre chains designed for single tyres just on the outer tyres.
- The sidewalls of radial tyres are prone to damage by tyre chains. Be sure to use tyre chains that are designed for radial tyres, or use winter tyres.

SERVICE AND MAINTENANCE

7

BEFORE SERVICE AND MAINTENANCE

7-3

DAILY CHECKS

7-15

**ENGINE-RELATED SERVICE AND
MAINTENANCE**

7-19

**CHASSIS-RELATED SERVICE AND
MAINTENANCE**

7-59

OTHER SERVICE AND MAINTENANCE

7-127

**INTERIOR AND EXTERIOR
MAINTENANCE**

7-147

MAINTENANCE DATA

7-157



BEFORE SERVICE AND MAINTENANCE

• Precautions for Checking and Adjustments	7-4
• Discarded Parts, Oils and Other Liquids	7-6
• Isuzu Genuine Oils and Grease	7-6
• Tools	7-7
• Inspection Hatches <input type="checkbox"/>	7-10
• Tilting the Cab <input type="checkbox"/>	7-12

Precautions for Checking and Adjustments

WARNING

- Make sure to turn off the engine and remove the key from the starter switch before performing any checks.
- Pull firmly on the parking brake lever and put the transmission in neutral.
 - If your vehicle is equipped with a manual transmission, make sure the gearshift lever is in "N".
 - If your vehicle is equipped with a AMT system, place the gearshift lever in "N" and make sure the shift indicator displays "N".
- Select a place with a solid and level surface to perform the checking and adjustment work. Make sure to chock the wheels. It would be very dangerous if the vehicle started to move.
- When raising the vehicle, use a suitable jack, not the one provided on the vehicle.
- After raising the vehicle and before going underneath to perform work, make sure the vehicle is supported with jack stands.
- When performing work on the electrical system, be sure to remove the cable from the negative terminal on the battery.
- The engine, exhaust pipe and radiator will be hot immediately after the vehicle is driven. Be careful around these parts to prevent burns. Perform all checks when the engine is cold.
- Do not perform work near an open flame or other heat sources.
- When working on the fuel line or fuel filter, remove the fuel tank filler cap. The fuel system is under pressure and the fuel will overspill unless the pressure is relieved, possibly leading to combustion or a fire.
- Do not let the engine run in poorly ventilated garages or sheds. This could cause carbon monoxide poisoning.

CAUTION

- Discarded parts, oil, grease and fluids could have an adverse effect on the environment. It is difficult to dispose of these, so have your Isuzu Dealer handle all checks and replacements.

**ADVICE**

- Use only appropriate tools.
- Oils, brake fluid, battery fluid and engine coolant have lubrication, cooling and rust prevention functions. If these liquids deteriorate through loss or contamination, it will cause a decline in the performance of the parts and such problems as seizure or malfunctioning. Replenish or change these liquids when performing the checks (daily and periodic checks) as required by the relevant regulations or in accordance with the Maintenance Schedule (when either the specified driving distance or period of time, whichever comes first, has expired).
- Confirm that all systems and components are normal after performing the work.
- Do not leave the removed parts or tools in the engine compartment. They could damage the equipment if caught in the belts or other moving components.
- Dirty water, dirt and other impurities seriously impair the effectiveness of the oil, grease and fluids, and damage the parts. Exercise all due caution to prevent waste or other refuse from coming in contact with parts or materials that have been removed when changing or replenishing them.

Discarded Parts, Oils and Other Liquids

- When changing oils, filters, engine coolant or other liquids, be sure to have a container ready in advance for their disposal.
- Use methods conforming to legal requirements for discarding or disposing of parts, oils, filters or coolant after change or replacement.

Isuzu Genuine Oils and Grease

Periodically replenishing and changing the oil and grease is extremely important for maintaining your vehicle's performance and preventing malfunctions.

Isuzu Motors guarantees the quality and performance of the Isuzu genuine oils and grease. We recommend the use of Isuzu genuine oils and grease for maintenance and service of your vehicle.



CAUTION

- Flames or other heat sources near spilled oil can cause a fire. Make sure to clean up all oil spills.

Tools

Storage Location in Single Cab Model

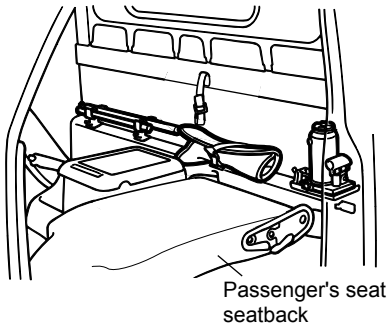

The tools are stored behind the driver's and passenger's seats. Tilt the seatbacks forward to take out the tools.

**ADVICE**

- If your vehicle has a back panel tray, the back panel tray must be removed before you can take out or store the tools.

Driver's Seat → Refer to page 3-18

Passenger Seat/Centre Seat V

→ Refer to page 3-19

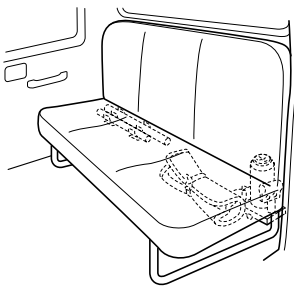
Storage Location in Crew Cab Model V

The tools are stored under the rear seat. To take out the tools, remove the seat cushion by pulling up the front.

**ADVICE**

- It is recommended that you familiarize yourself with the contents and use of the various tools and the jack before using them.
- After finishing work with the tools, return them to the correct storage location and ensure that they will not move while the vehicle will be in motion.
- Triangle reflectors must always be kept inside the vehicle.

Tools Carried in Your Vehicle

**Model with dual tyres
(NLR/NNR/NPR/NQR/NPS models)**

Illustration of the spare tyre hanger top shape as shown.

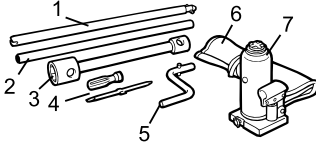

No.	Tool name
1	Jack bar/Spare tyre removal bar
2	Wheel nut wrench handle
3	Wheel nut wrench
4	Screwdriver (with switchable Phillips and flat heads)
5	Crank handle for spare tyre removal
6	Tool bag
7	Jack

**ADVICE**

- Be sure to carry all of the provided tools in the vehicle.

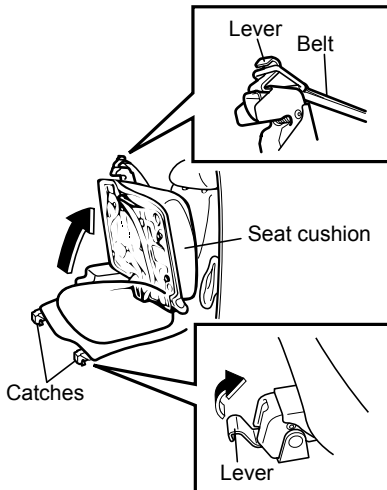
Inspection Hatches vEngine Maintenance Lid v**Opening**

1. Lift the catch levers located at the front of the passenger's seat cushion to release the lock.
2. Lift up the seat cushion and attach the belt extending from behind the seatback to the left catch lever to hold the cushion in the raised position.

Closing

1. Detach the belt from the catch lever and lower the seat cushion to a point approximately 30 cm (12 in) above its original position. Allow the seat cushion to drop into place, and then secure it using the catch levers.
2. Gently push and pull the seat cushion to make sure that it has been securely locked in place.

**CAUTION**

- Take care to avoid jamming fingers, hands or any other part of your body when returning the seat cushion to its original position. In addition, confirm that the seat cushion is firmly locked. A seat with an improperly locked cushion will be unstable during driving, possibly causing an accident.

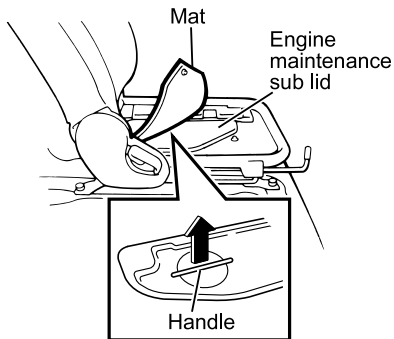
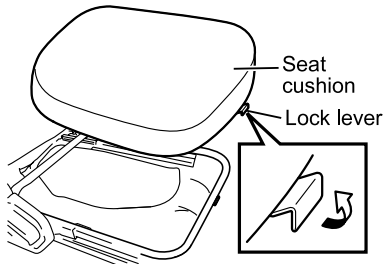
Engine Maintenance Sub Lid V**Opening**

1. Unlock the driver's seat cushion by lifting the lock lever (red) while pulling toward you. Then remove the cushion.
2. Lift up the mat, and then remove the engine maintenance sub lid by pulling the handle.

Closing

1. Reinstall the engine maintenance sub lid and place the mat over it.
2. Place the seat cushion with its rear end first and press it down.

Rear Inspection Hatches (Crew Cab Model) V

All rear inspection hatches are located in the floor in the vicinity of the rear seat. To open an inspection hatch, lift the floor mat first, and then grip the handle on the hatch to raise the hatch.

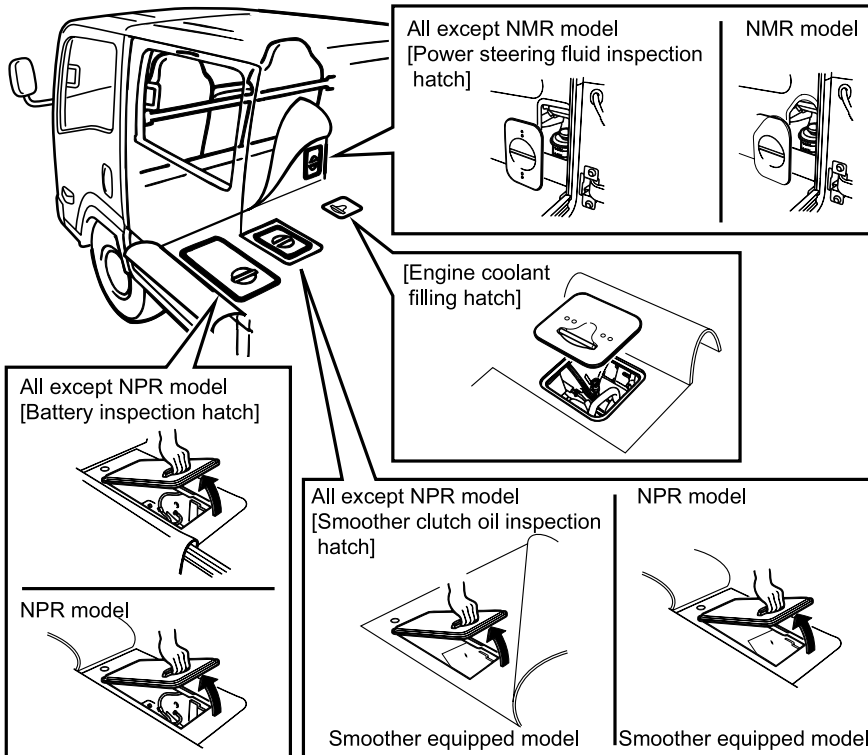

Power Steering Fluid

→ Refer to page 7-120

AMT Clutch Oil SA

→ Refer to page 7-109

Handling the Battery

→ Refer to page 7-138

Engine Coolant

→ Refer to page 7-34

Tilting the Cab  **WARNING**

- Do not touch the lock (E) on the cab support while the cab is tilted. If you touch it, the lock will release. Refer to Step 4 of the following "Tilting Up the Cab" section and be sure to follow the instructions given.

 **CAUTION**

- Tilt the cab only on a level surface.
- Apply the parking brake firmly and make sure that the gearshift lever is in the "N" position.
- Check the areas in front of and above the cab for sufficient clearance when tilting the cab indoors. (Particular care is required if your vehicle is equipped with an air deflector.)
- When tilting the cab, close the left and right doors securely. You should avoid opening or closing the doors when the cab is tilting.
- Confirm that people are not near the vehicle or inside the cab when tilting the cab.
- Confirm that the lock lever for the tilt support is fully engaged in the lock position after the cab is tilted.
- The silencer, exhaust pipe and diesel particulate defuser (DPD) will be very hot immediately after driving. Use all due caution to avoid accidentally touching these when doing a cab tilt operation.
- Do not tilt the cab when objects are placed on or in the instrument panel, seats, cup holders or floor surface.
- Tilt the cab only with the engine turned off.
- Make sure everything has been removed from the roof rack.
- Remove any ice or snow accumulating on the top of the bumper before tilting the cab. Failure to do so could damage the bumper, lights or other vehicle components.
- When you must unavoidably open or close a tilted cab's door, securely support the weight of the door while opening or closing it. It is dangerous to release the door from your hand when it is being opened or closed. The door could hit you or someone and cause an injury, or the door could be damaged. Confirm that the door is completely closed after closing it.

Tilting Up the Cab

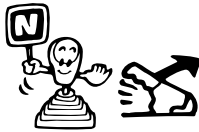

1. Apply the parking brake firmly and make sure that the gearshift lever is in the "N" position. Close all doors fully.

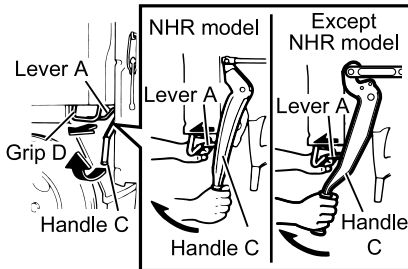

2. Holding the grip (D) in your left hand, pull the lever (A) toward you using your finger, and then raise the handle (C) using your right hand.

3. Holding the grip (D) in your left hand, pull the lever (B) toward you using your right hand to raise the cab.

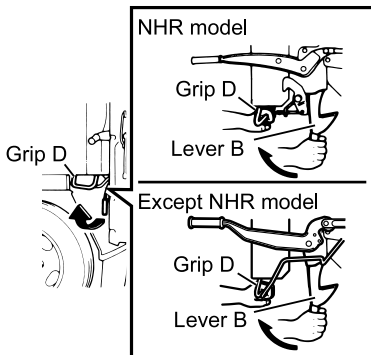

4. When you have raised the cab, support the cab with the grip (D) using your left hand and confirm that the tilt support's lock (E) has been securely engaged.

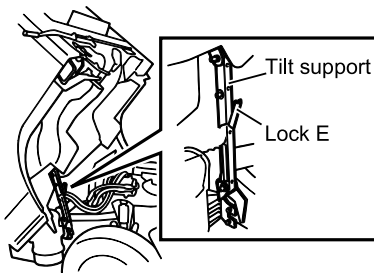

5. If a lock pin is equipped, insert it correctly.

WARNING

- If the lock (E) has not been fully engaged, there is a danger that the cab may accidentally fall.

Lowering the Cab

WARNING

- After lowering the cab, make sure the cab is securely locked.

CAUTION

- Note that when a load is present inside or outside the cab, it will lower faster.

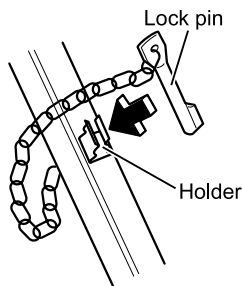

1. If a lock pin is equipped, remove it and place it in the holder.

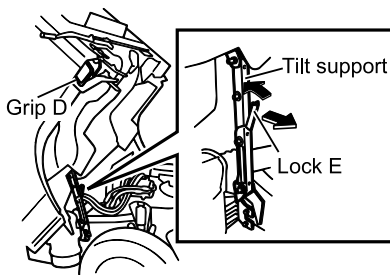

2. Holding the grip (D) in your left hand to support the cab, release the lock (E) using your right hand and pull the tilt support towards the rear of the vehicle to fold it down.

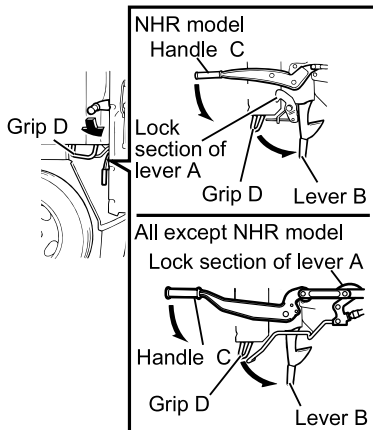

3. Holding the grip (D), drop the cab with enough force to ensure that the lever (B) engages, and then confirm that this lever has engaged securely.
4. Lower the handle (C) until the lever (A) is fully locked.

**NOTE**

- Confirm that the lock section of lever (A) has securely engaged.

DAILY CHECKS

• Daily Checks (Preoperational Checks)	7-16
• Checking Components that Showed Abnormalities during Previous Operation	7-18

Daily Checks (Preoperational Checks)

Check your vehicle for the items listed below before starting the day's operation to ensure safe, trouble-free operation. Also, make note of the distance the vehicle has covered and the conditions under which the vehicle has been operated to be able to determine the inspection intervals most appropriate for your specific vehicle and adequately service it according to inspection results.

If the checks reveal an abnormality or if there are components that showed abnormalities during the previous operation, have the vehicle repaired by your Isuzu Dealer before using the vehicle.

Daily Check (Preoperational Check) Items

[1. Checking components that showed abnormalities during the previous operation]

Check item	Reference page
Checking components that showed abnormalities during the previous operation	7-17

[2. Checks performed with the engine inspection hatch opened or cab tilted]

Check item	Reference page
Fan belt looseness and damage	7-45
Engine oil level	7-22
Engine coolant level	7-35
Power steering fluid level	7-120

[3. Checks performed in the driver's seat]

Check item	Reference page
Brake fluid level (and clutch fluid level <input type="checkbox"/> M/T)	7-62 (7-1010)
Brake pedal free play	7-70
Clutch pedal free play <input type="checkbox"/> M/T	7-104
Operation of meters, gauges and warning/indicator lights	4-7, 4-19
Engine startability, abnormal noise and color of exhaust gases	7-20
Parking brake lever stroke	7-72
Windshield washer fluid spray condition and windshield wiper effectiveness	7-133, 7-134
Windshield washer fluid level	7-133
Steering wheel play and mounting condition	3-21
Operation of horn and turn signal lights	4-65, 4-73
Fuel remaining quantity	4-13
Operation of door locks	3-7

[4. Checks performed during a walk around the vehicle]

Check item	Reference page
Illumination, flashing, contamination and damage of lights	7-137
Battery fluid level	7-141
Leaf spring damage	—
Leakage of oil, coolant, fuel, brake fluid, power steering fluid and HBB oil.	—
Water collecting in the fuel filter (bottom)	7-53

[5. Checking wheels and tyres]

Check item	Reference page
Air pressure	7-81
Cracks and other damage	7-83
Abnormal wear	7-83
Tread depth	7-83
Disc wheel mounting condition	7-84

[6. Checks performed while driving the vehicle]

Check item	Reference page
Brake effectiveness	7-71
Driving condition at low speeds and during acceleration	7-21

Checking Components that Showed Abnormalities during Previous Operation

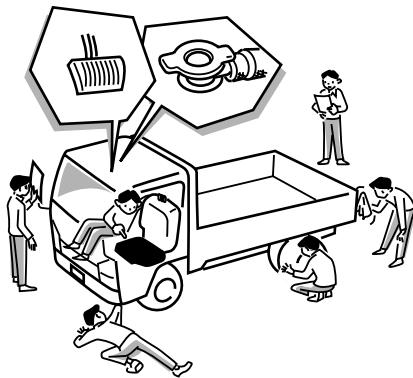

Check the components that showed abnormalities during the previous operation. Have any abnormalities repaired by your Isuzu Dealer before using the vehicle.



ENGINE-RELATED SERVICE AND MAINTENANCE

• Engine Conditions	7-20
• Engine Oil	7-22
• Engine Coolant	7-34
• Fan Belt	7-44
• Air Cleaner	7-49
• Fuel Filter	7-53
• Diesel Particulate Defuser (DPD)	7-60

Engine Conditions

Checking the Engine for Startability and Abnormal Noises

1. Make sure the parking brake is securely engaged. Step firmly on the brake pedal.
2. Make sure the transmission is in neutral.



CAUTION

- If your vehicle is equipped with the AMT system, the engine will not start unless the transmission is actually in neutral.
- For safety, firmly press the brake pedal before starting the engine.

3. Turn the starter switch to start the engine.

Check that the engine starts quickly with no abnormal noises.

Starting the Engine → Refer to page 4-4

Checking Condition of the Engine at Low Speeds and during Acceleration



1. Make sure the transmission is in neutral and the parking brake is securely engaged.
2. Turn the starter switch to start the engine, and run it to warm up.

Starting the Engine

→ Refer to page 4-4

3. Check that the engine is running at a speed within the standard idle speed range.

Idling Control Knob

→ Refer to page 4-62



NOTE

- During regeneration of the diesel particulate defuser (DPD), the engine idle speed may increase.

Diesel Particulate Defuser (DPD)

→ Refer to page 4-154

4. Drive the vehicle, making sure the accelerator pedal does not stick when gradually accelerating, the engine speed rises smoothly and it does not knock.

Engine Oil

Engine oil is an important factor determining engine performance and longevity. Be sure to use only the specified oil and oil filters. The engine oil level must be checked and the oil should be changed regularly according to the Maintenance Schedule.



NOTE

- When particulate matter (PM) has accumulated to a preset level in the diesel particulate defuser (DPD) filter, the filter is automatically regenerated through combustion. To make this regeneration (combustion) possible, a small amount of fuel is injected into the engine combustion chamber after firing. This causes fuel to gradually become mixed with the engine oil, and the engine oil level will rise beyond the original level. This does not indicate a malfunction of the engine.

Checking the Engine Oil Level

Park the vehicle on a level surface and check the engine oil level before starting 30 minutes after turning off the engine. To check the oil level, remove the oil dipstick, wipe off the end with a clean cloth, reinsert it and then gently remove it.

If the oil level is between the "Inspection MAX" and "MIN" marks, the oil is at the correct level. Also check to see if there are any oil leaks.

4JJ1 engine model

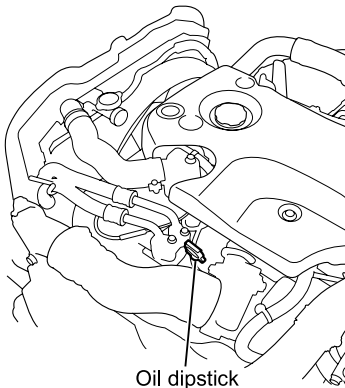

4HK1 engine model

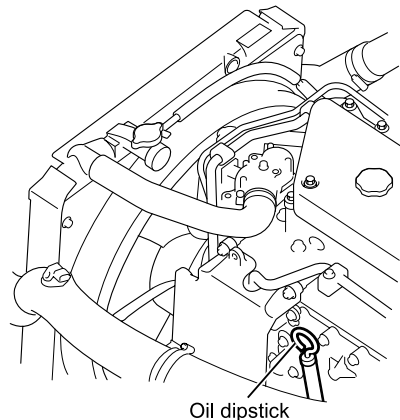

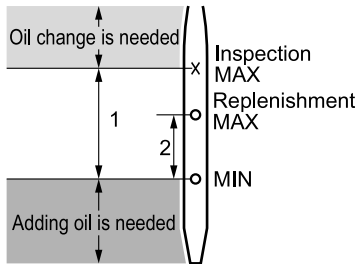

Checking the Engine Oil Level

1. Remove the oil dipstick and wipe off any oil on the oil dipstick.
2. Reinsert the oil dipstick fully and then gently remove it. If the oil level is between the "Inspection MAX" and "MIN" marks (range 1), the oil is at the correct level.
3. If the oil level is too low, add oil to the "Replenishment MAX" mark (range 2). If the oil level is beyond the "Inspection MAX" level, then the oil needs to be changed.
4. Reinstall the oil dipstick into position after checking the oil level.



ADVICE

- Any oil level above the "Inspection MAX" mark on the oil dipstick may cause engine malfunctions. Change the oil whenever its level exceeds the "Inspection MAX" mark.
- Fuel will gradually become mixed with the engine oil, thinning it out. Be sure to change the oil at the specified intervals.



NOTE

- Perform all engine oil level checks on a level surface before starting the engine.
- The oil level cannot be checked correctly when the engine is running.
- Fuel will gradually become mixed with the engine oil, and the engine oil level will rise beyond the original level. This does not indicate an engine malfunction.
- Wait for at least 30 minutes after stopping the engine when measuring the oil level after the engine has been operated.

Adding the Engine Oil

When the engine oil level is near the "MIN" mark on the oil dipstick, remove the oil filler cap and add the oil. Remove the oil dipstick at this time. Use only the specified engine oil.

4JJ1 engine model

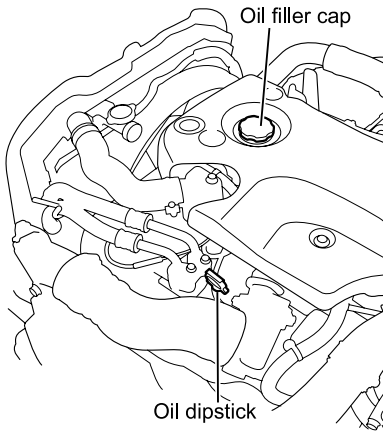

4HK1 engine model

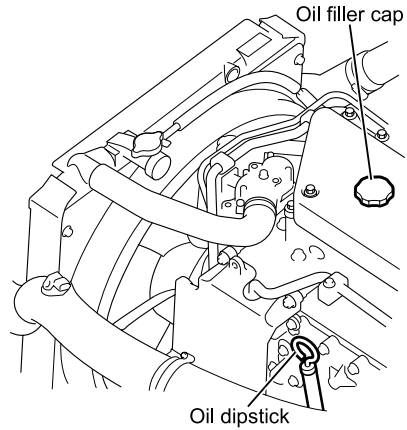

 **WARNING**

- When adding oil, be careful not to spill any, but keep a workshop rag handy just in case there are any spills. If any oil should spill onto the engine, carefully wipe it away. If this precaution is not taken, the spilled oil could ignite and a fire could spread.
- Do not leave flammable items, such as rags or gloves, in the engine compartment. They could cause a fire.
- The engine oil is hot after driving, so when changing the oil after driving, be careful not to be scalded.

 **ADVICE**

- Engine oil lubricates and cools the engine's internal components. The quality of the oil is degraded and the quantity of oil is reduced by evaporation, discharge and combustion during the engine's operation. Continually using the same oil without checking the level, or without replenishing and changing it could cause seizure or damage to the engine. Add or change the oil when the quality of the oil has been degraded or the quantity is reduced, even if this occurs before expiration of the specified intervals in the Maintenance Schedule, which will differ depending on the conditions of use.
- Prevent dirt from entering the filler port when adding the oil. If foreign matter mixes with the oil, it could damage the engine.
- Adding oil above the "Inspection MAX" mark on the oil dipstick could result in faulty engine operation. Be sure to check the oil level by using the oil dipstick.
- Failure to use DPD compatible oil could result in engine or DPD breakdown, or in poor fuel efficiency. Be sure to use DPD compatible engine oil.

Changing the Engine Oil and Oil Filter

Engine oil and the oil filter are important factors in engine performance and lifespan. Be sure to use only the specified oil and oil filters. The engine oil level must be checked and the oil should be changed regularly according to the Maintenance Schedule.



ADVICE

- Use the oil quantities indicated below only as guidelines when changing the engine oil. After changing the oil, make sure the oil is at the required level.
- Failure to use DPD compatible oil could result in engine or DPD breakdown, or to poor fuel efficiency. Be sure to use DPD compatible engine oil.

Quantity of engine oil to be changed

Engine model	Oil quantity [Reference value]	
	When changing oil only	When changing oil and filter
4JJ1	9.0 litres (2.38 US gal./1.98 Imp gal.)	10.0 litres (2.64 US gal./2.20 Imp gal.)
4HK1 (2WD)	10.5 litres (2.77 US gal./2.31 Imp gal.)	13.0 litres (3.43 US gal./2.86 Imp gal.)
4HK1 (4WD)	9.5 litres (2.51 US gal./2.09 Imp gal.)	12.5 litres (3.30 US gal./2.75 Imp gal.)

Maintenance Schedule

→ Refer to page 7-159

Recommended Fluids, Lubricants and Diesel Fuels

→ Refer to page 7-172

Changing the Oil (4JJ1 Engine Model)

1. Clean around the oil filler cap so that foreign matter does not enter.
Remove the oil filler cap.
2. Place a container for receiving the oil beneath the oil pan and the oil filter.
Remove the oil pan drain plug and the oil filter drain plug to discharge the oil into the container.

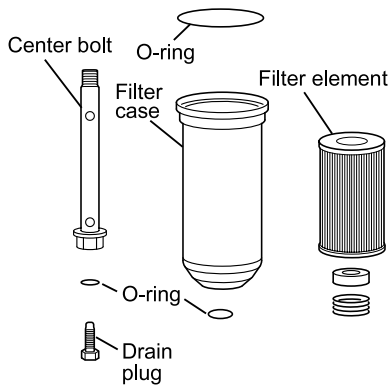
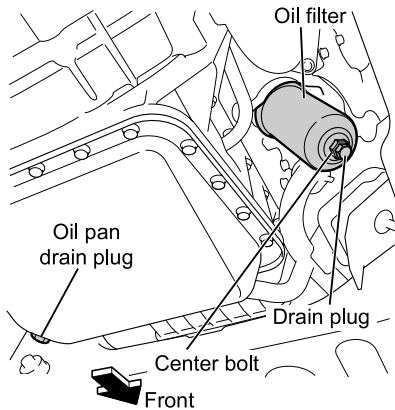

ADVICE

- Drained oil must be disposed of in a method conforming to the regulatory requirements in your country.

3. Loosen the centre bolt by turning it counterclockwise using a socket wrench to remove the filter case.
Next, remove the filter element.
4. To ensure that the new oil filter makes good contact, wipe the filter mounting surface clean using a workshop rag.
5. Replace the three O-rings and filter element with new parts. Tighten the centre bolt using the socket wrench.

Oil filter centre bolt tightening torque

44 N·m (4.5 kgf·m/33 lb·ft)

ADVICE

- When installing the oil filter, be careful not to let the O-rings catch other parts. This may cause oil leakage.

6. Reinstall and tighten the oil pan drain plug and oil filter drain plug.

Drain plug tightening torque	
Oil pan	83.3 N·m (8.5 kgf·m/61 lb·ft)
Oil filter	25 N·m (2.5 kgf·m/18 lb·ft)

**ADVICE**

- The dirt on the plug must be wiped off before reinstalling it.

7. Remove the oil dipstick and carefully fill the specified oil into the oil filler.
8. Install the oil dipstick and the oil filler cap. Start the engine 5 minutes after refilling it with the new oil and let it idle. While the engine is idling, check to see if any oil leaks around the oil filter or drain plug.

**ADVICE**

- Avoid revving up the engine, as it could damage the engine.

9. Shut off the engine. Then, after waiting at least 30 minutes, check the oil level using the oil dipstick.

**WARNING**

- Bringing flames or other heat sources near spilled engine oil could cause a fire. Make sure to wipe it all up.
- Do not leave flammable items, such as rags or gloves in the engine compartment beneath the cab. They could be the cause of a fire. Also, do not forget your tools.

**ADVICE**

- Avoid revving up the engine, as it could damage the engine.
- Do not fill the engine with oil above the "Inspection MAX" mark on the oil dipstick. Overfilling could damage the engine.

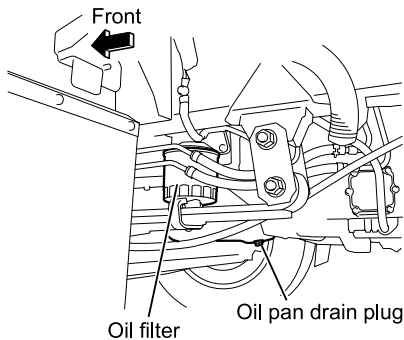

Changing the Oil (4HK1 Engine model)

1. Clean around the oil filler cap so that foreign matter does not enter. Remove the oil filler cap.
2. Place a container for receiving the oil beneath the oil pan and the oil filter.
3. Remove the oil pan drain plug to discharge the oil into the container.



ADVICE

- Drained oil must be disposed of in a method conforming to the regulatory requirements in your country.

4. Use the special oil filter wrench to remove the oil filter.
5. Lightly coat the gasket of the new oil filter with clean engine oil.
6. Install the new oil filter. After the filter gasket comes in contact with the surface to which it will be attached, use the special oil filter wrench and tighten it by 1 1/4 (one and a quarter) turns.



ADVICE

- When installing the oil filter, make sure the gasket is not caught in the screw threads. This could cause oil leaks.

7. Make sure that the oil pan drain plug is securely tightened.

Oil pan drain plug tightening torque

4HK1 engine model	83 N·m (8.5 kgf·m/ 61 lb·ft)
-------------------	------------------------------------------------

**ADVICE**

- The dirt on the plug must be wiped off before reinstalling it.

8. Remove the oil dipstick and carefully fill the specified oil into the oil filler.
9. Install the oil dipstick and the oil filler cap. Start the engine 5 minutes after refilling it with the new oil and let it idle. While the engine is idling, check to see if any oil leaks around the oil filter or drain plug.

**ADVICE**

- Avoid revving up the engine, as it could damage the engine.

10. Shut off the engine. Then, after waiting at least 30 minutes, check the oil level using the oil dipstick.

**WARNING**

- Bringing flames or other heat sources near spilled engine oil could cause a fire. Make sure to wipe it all up.
- Do not leave flammable items, such as rags or gloves in the engine compartment beneath the cab. They could cause a fire. Also, do not forget your tools.

**ADVICE**

- Avoid revving up the engine, as it could damage the engine.
- Do not fill the engine with oil above the "Replenishment MAX" mark on the oil dipstick. Overfilling could damage the engine.

Engine Coolant

The engine coolant must be changed according to the Maintenance Schedule.

Maintenance Schedule

→ Refer to page 7-159

Recommended Fluids, Lubricants and Diesel Fuels

→ Refer to page 7-172

WARNING

- Check, replenish or change the engine coolant only after the engine has sufficiently cooled down.
- If the coolant is still hot, do not remove the radiator cap. Hot vapor will come out and you may be scalded. The coolant in the surge tank will be hot, which may also cause scalding. Perform all checks, replenishment and change when the coolant temperature has lowered.
- When removing the radiator cap or surge tank cap, use a thick cloth to cover the cap and turn it slowly.
- Engine coolant is toxic and must not be ingested. If coolant gets in your eyes, rinse them immediately.
- Engine coolant is flammable, and therefore, it must be kept away from flames and other heat sources. Engine coolant also could ignite if it comes in contact with a hot surface, such as the exhaust manifold. Exercise caution to prevent this from happening.

NOTE

- Use a mixture of tap water and engine coolant at an appropriate concentration.

Preparing Coolant → Refer to page 7-43

Checking the Engine Coolant Level

Single cab model

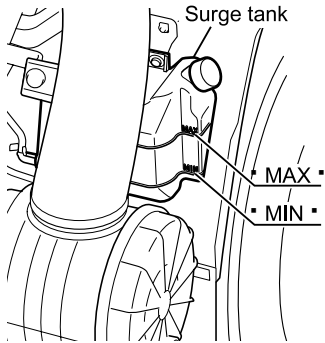

The surge tank is located behind the front-right wheel. When the engine has cooled down, make sure that the fluid level in the surge tank is no lower than the "MIN" line.

Also, check to make sure there are no leaks from the radiator or radiator hose. Check for fluid or stains on the ground showing leaks where the vehicle is parked. Contact your Isuzu Dealer when you discover leaks.



CAUTION

- Using the vehicle when there are leaks can lead to engine seizure.

Crew cab model

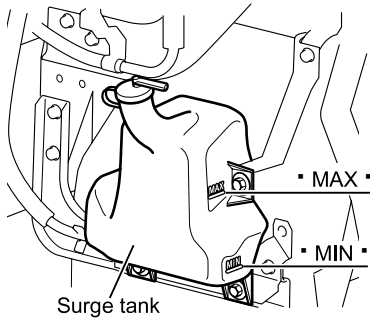

Rear Inspection Hatches (Crew Cab Model)

→ Refer to page 7-11

Adding the Engine Coolant

Single cab model

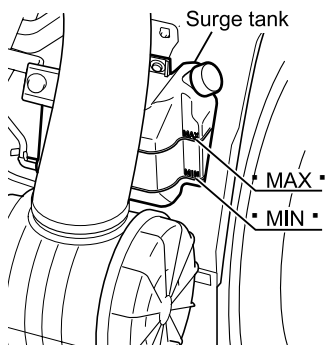

When the engine coolant level in the surge tank is below the "MIN" line, open the tank cap and fill to near the "MAX" line with a mixture of tap water and engine coolant at an appropriate concentration. Tighten the cap securely after the coolant has been replenished.

WARNING

- Check, replenish or change the engine coolant only after the engine has sufficiently cooled down.

Crew cab model

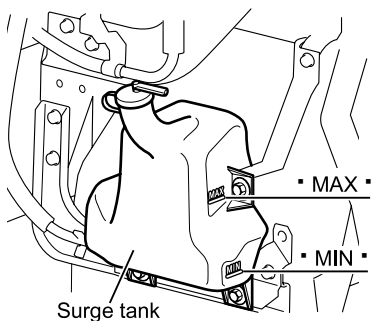

ADVICE

- Check the surge tank to determine engine coolant level. In situations, however, where the level in the surge tank rises or falls suddenly, open the radiator cap and check the level within the radiator itself.
- When the engine is still hot, take care to prevent engine coolant from contact with the exhaust manifold. Any such contact could result in exhaust manifold damage.
- If the level of engine coolant changes rapidly, have your vehicle inspected at your Isuzu Dealer.

Changing the Engine Coolant



ADVICE

- Drained coolant must be disposed of in a method conforming to the regulatory requirements in your country.

Engine Coolant Level

Engine model	Coolant quantity [Reference value]
4JJ1	10.0 litres (2.64 US gal./ 2.20 Imp gal.)
4HK1	18.0 litres (4.76 US gal./ 3.96 Imp gal.)

4JJ1 engine model
Radiator cap

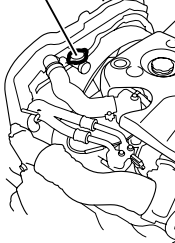

4HK1 engine model
Radiator cap

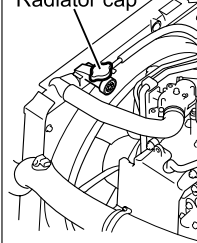

Draining the Cooling System

When changing the engine coolant, also clean the radiator cap, radiator and coolant passages.

1. Confirm that the engine has fully cooled down before starting work.
2. Remove the radiator cap.
3. Open the coolant drain plugs on the radiator and the engine to let the coolant run out.
4. Close the coolant drain plugs on the radiator.

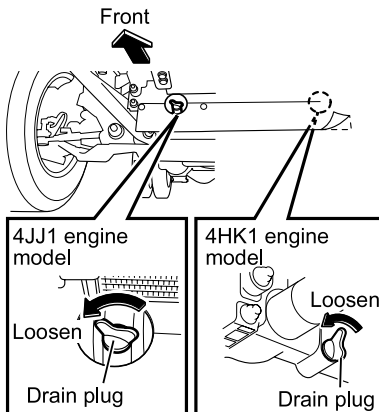

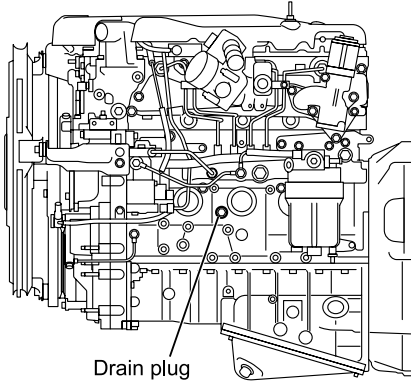
4JJ1 engine model

Drain plug

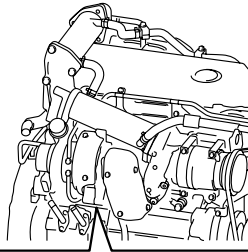
4HK1 engine model

Drain plug

Cleaning the Radiator Core

Cooling efficiency is compromised when there is dirt or dust plugging air passages in the radiator core. It also could cause corrosion of the radiator core. Periodically wash the radiator core with water.

**ADVICE**

- When cleaning the radiator core, do not crush or damage the fins.

5. For the 4JJ1 engine, apply sealant (LOCTITE® 262 or equivalent) to the screw threads of the engine drain plug before installing it.

For the 4HK1 engine, attach the gasket in the drain plug before installing it.

Engine drain plug tightening torque

21.6 N·m (2.2 kgf·m/16 lb·ft)

**CAUTION**

- Do not start the engine if there is no coolant in the radiator after draining. This could cause the engine to seize up.

**ADVICE**

- Tighten the radiator drain plug by hand. Tightening with pliers or some other tool could damage it.

4JJ1 engine model

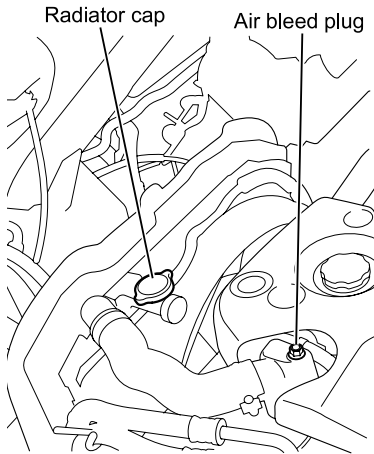

Cleaning the Coolant Passages

1. Remove the radiator cap, and fill the radiator with tap water to the top of the opening.

Remove the air bleed plug from the water outlet pipe before filling the coolant. After filling with water, firmly tighten the air bleed plug.

Engine	Air bleed plug tightening torque
4JJ1	15.3 - 28.4 N·m (1.5 - 2.9 kgf·m/11 - 21 lb·ft)
4HK1	14 - 24 N·m (1.4 - 2.4 kgf·m/122 lb·in - 17 lb·ft)

4HK1 engine model

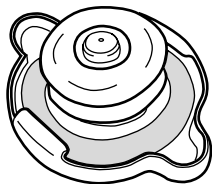
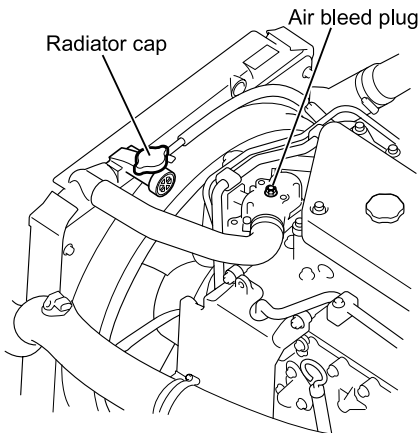

2. Check and clean the radiator cap. Replace the cap if it is damaged.
3. Install and securely fasten the radiator cap.

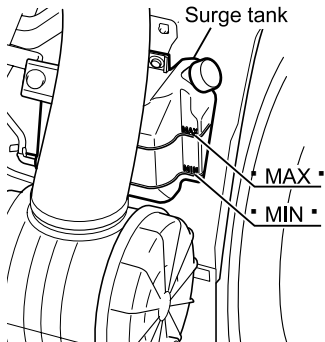
Single cab model

4. Fill the surge tank with tap water to the "MAX" line.
5. Close the cap of the surge tank.
6. Start the engine and let it idle for 20 minutes. Stop the engine, wait until it cools down, and then drain out the water.

Draining the Cooling System

→ Refer to page 7-37

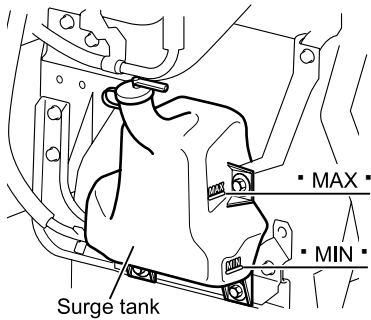
Crew cab model

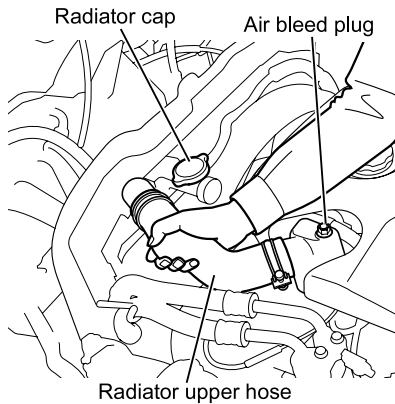
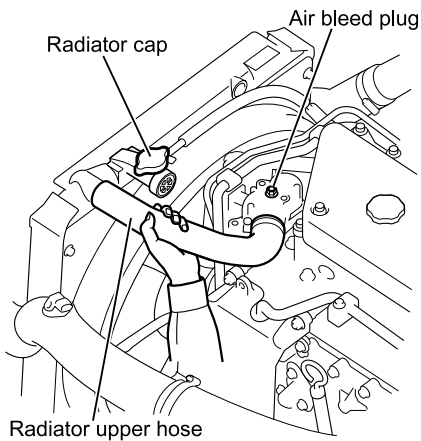
4JJ1 engine model**4HK1 engine model****Filling the Cooling System**

1. Confirm that the engine has fully cooled down before starting work.
2. Remove the radiator cap, and fill the radiator with coolant to the top of the filler opening.

Remove the air bleed plug from the water outlet pipe before pouring coolant. Replace the gasket of the air bleed plug with a new one. After filling with coolant, firmly tighten the air bleed plug.

Engine	Air bleed plug tightening torque
4JJ1	15.3 - 28.4 N·m (1.5 - 2.9 kgf·m/11 - 21 lb·ft)
4HK1	14 - 24 N·m (1.4 - 2.4 kgf·m/122 lb·in - 17 lb·ft)

3. Squeeze the radiator upper hose two or three times.

If this action results in air being discharged from the hose and the level of engine coolant goes down, add coolant to the top of the radiator filler opening.

4. Install and securely fasten the radiator cap.

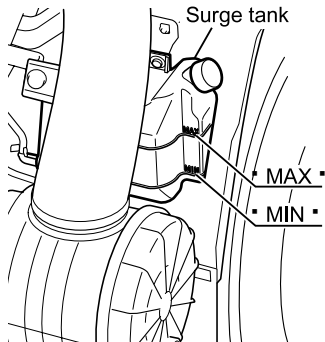
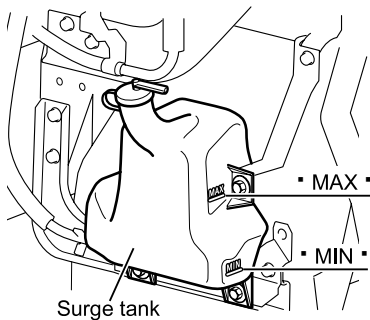
Single cab model**Crew cab model**

5. Fill the surge tank with coolant to the "MAX" line. Close the cap of the surge tank.
6. Close the water outlet pipe's air bleed plug.
7. Start the engine, let it idle for 2 or 3 minutes and then stop the engine.
8. After making sure that the coolant is no longer hot, remove the radiator cap. If the coolant level has lowered, replenish with coolant up to the radiator filler opening. If the coolant level is abnormally low, check for leaks from the radiator, the engine cooling circuit or the surge tank hose.
9. After firmly closing the radiator cap, run the engine at about 2,000 r/min to warm it up.
10. When the needle of the engine coolant temperature gauge reaches the centre, let the engine idle at normal idle speed for 5 minutes and then stop the engine.
11. After making sure that the coolant is no longer hot, remove the radiator cap, check the coolant level, and replenish with coolant up to the radiator filler opening, if necessary. If the coolant level is abnormally low, check for coolant leaks.
12. Firmly close the radiator cap.
13. Replenish the coolant in the surge tank up to the "MAX" line, and then close the surge tank cap.

**ADVICE**

- Using any engine coolant other than the recommended one can shorten engine life, as it cannot sufficiently protect the cooling system from corrosion.

Preparing Coolant

Use a mixture of engine coolant and tap water as the engine coolant to prevent engine damage due to freezing and to protect the cooling system from corrosion. Use only an Isuzu recommended mixed with tap water at an appropriate concentration.

Engine coolant concentration and freezing temperature

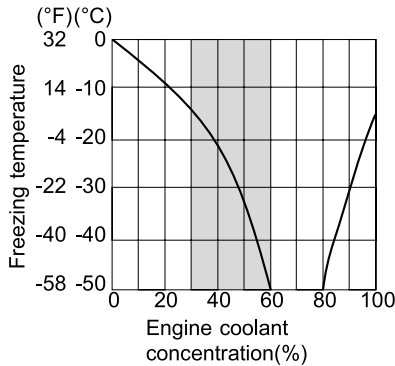

When using Isuzu genuine engine coolant, the percentage of engine coolant in the coolant should be 50%. If it is more than 60%, overheating is likely to occur, while if it is less than 30%, the coolant's anti corrosion performance will be inadequate.

Select the mixture ratio for a freezing temperature that is about 10°C (18 °F) lower than the expected outside temperature.

When using an engine coolant other than the Isuzu genuine engine coolant (Isuzu specified product), use the following mixture ratios:

When the outside temperature is above -40°C (-40°F): 50% engine coolant and 50% tap water

When the outside temperature is -40°C (-40°F) or lower: 60% engine coolant and 40% tap water

Engine Coolant Quantity

The quantity of coolant is indicated below for your use as a guideline when changing the coolant. After changing the coolant, check that the coolant is up to the specified level.

Engine model	Coolant quantity [Reference value]
4JJ1	10.0 litres (2.64 US gal./2.20 Imp gal.)
4HK1	18.0 litres (4.76 US gal./3.96 Imp gal.)

**ADVICE**

- Use only an Isuzu-recommended engine coolant.
- Use tap water, not well water or river water, when preparing coolant for replenishing or changing.
- If the coolant decreases rapidly, go immediately to the nearest Isuzu Dealer for a check or repair.
- Tighten the radiator drain plug by hand. Tightening with pliers or some other tool could damage it.
- If the specified amount of engine coolant is not used, the aluminum components in the heater unit and other parts of the cooling system could be corroded, causing coolant leaks.

Engine Coolant → Refer to page 7-34

Fan Belt**CAUTION**

- A V-ribbed belt is used for the fan belt. This type of belt requires the tension to be adjusted more accurately than is required with the conventional V belt. Inappropriate tension could cause the belt to make noise or break. When the fan belt is damaged, electricity is not properly generated or becomes a cause of engine overheating. You must check the tension of the fan belt carefully.
 - Use Isuzu genuine parts when changing the fan belt.
- [Follow this to properly adjust belt tension]
- Adjust the belt using the following method after installing either a new or used belt.
 - Align the belt and pulley grooves and adjust the belt tension using the indicated method.
 - Start the engine, and let it idle for about 1 minute to equalize the tension of the belt at all spans between the pulleys.
 - Stop the engine, and then check the belt tension. If the tension is inappropriate, readjust it to the specified standard value.
 - Use the new belt tension specification only after replacing the belt with a new one.

Inspection

4JJ1 engine model
Engine with 50A alternator

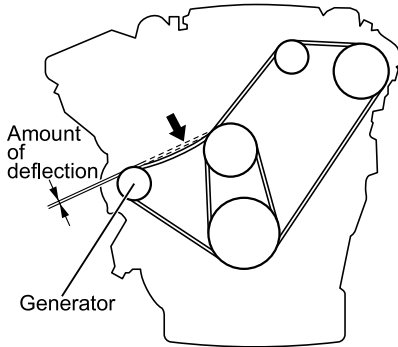

4JJ1 Engine Model

Press the centre of the span between pulleys (see the figure) of the belt with a force of **98 N (10.0 kgf/22 lb)** and check the amount of deflection. The amount of deflection must fall within the standard value range indicated below. Otherwise, adjust the tension or replace the belt. Also check the fan belt for cracks or other damage. If there are cracks or damage, replace the belt.

4JJ1 engine model
Engine with 80A alternator

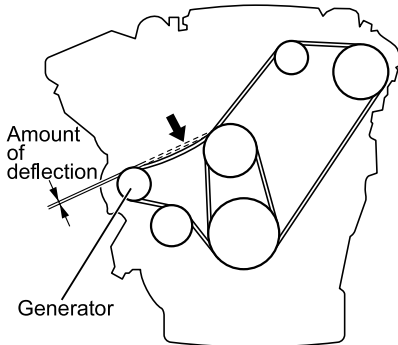

	Standard value [amount of deflection]	Standard value [vibration frequency]
New belt	4 - 6 mm (0.16 - 0.24 in)	212 - 236 Hz
Used belt	6 - 8 mm (0.24 - 0.31 in)	181 - 195 Hz

Engine with 50A alternator

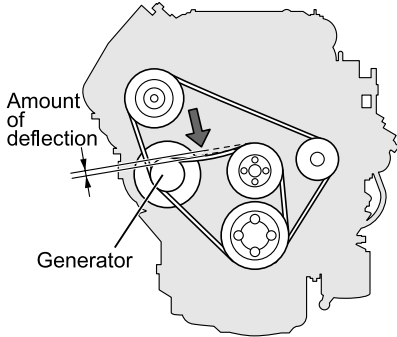

4HK1 Engine Model

Press the centre of the span between pulleys (see the figure) of the belt with a force of **98 N (10.0 kgf/22 lb)** and check the amount of deflection. The amount of deflection must fall within the standard value range indicated below. Otherwise, adjust the tension or replace the belt. Also check the fan belt for cracks or other damage. If there are cracks or damage, replace the belt.

Engine with 80A alternator

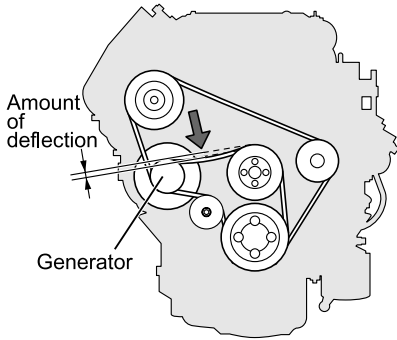

Alternator	Standard value [amount of deflection]		Standard value [vibration frequency]
	50A	New belt	5 - 7 mm (0.20 - 0.28 in)
Used belt		6 - 8 mm (0.24 - 0.31 in)	178 - 190 Hz
80A	New belt	5 - 7 mm (0.20 - 0.28 in)	187 - 209 Hz
	Used belt	6 - 8 mm (0.24 - 0.31 in)	161 - 173 Hz

Adjustment and Replacement

4JJ1 engine model

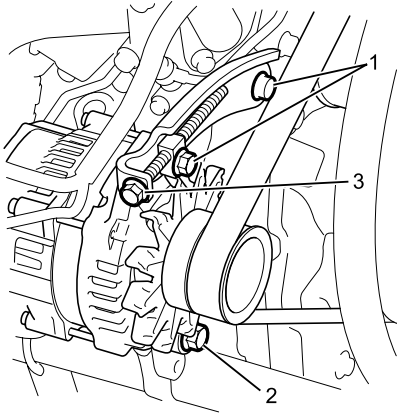

4HK1 engine model with a 50A alternator

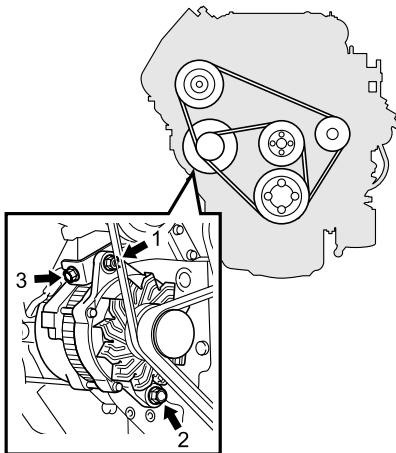

4JJ1 Engine Model or 4HK1 Engine Model with 50A Alternator

Adjustment

1. Loosen the alternator's upper and lower nuts and bolts (1, 2).
2. Turn the adjusting bolt (3) until the belt tension falls within the standard value range.
3. After adjustment, firmly tighten all the loosened nuts and bolts.

Changing the Belt

1. Remove the air conditioning compressor belt.
2. Loosen the alternator's upper and lower nuts and bolts (1, 2), and then detach the belt from the pulleys.
3. Take out the belt through the opening in the fan.
4. Insert the new belt through the opening in the fan and install the belt while aligning its grooves with those in the alternator pulley and crankshaft pulley.
5. Turn the adjusting bolt (3) until the belt tension falls within the standard value range.
6. After adjustment, firmly tighten all the loosened nuts and bolts.
7. Install the air conditioning compressor belt.

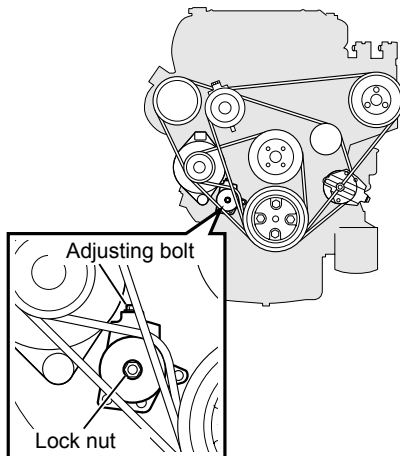
**4HK1 engine model with 80A
alternator****4HK1 Engine Model with 80A
Alternator****Adjustment**

1. Loosen the tensioner's lock nut.
2. Adjust the belt tension with the adjusting bolt.
3. When the tension has been adjusted, securely fasten the tensioner's lock nut.

Changing the Belt

1. Loosen the tensioner's lock nut.
2. Loosen the adjusting bolt and remove the belt from the pulleys.
3. Take out the belt through the opening in the fan.
4. Insert the new belt through the opening in the fan, and install the belt while aligning its grooves with those in the pulleys.
5. Turn the adjusting bolt until the belt tension is within the standard value range.
6. When the tension has been adjusted, securely fasten the tensioner's lock nut.

Air Cleaner

Change the air cleaner element after cleaning 6 times, or in accordance with the Maintenance Schedule.

Maintenance Schedule

→ Refer to page 7-159

Checking the Air Cleaner



Remove the air cleaner element and check to see if it is blocked by dirt.

If the air cleaner indicator light comes on (model with multi information display (MID)), check the air cleaner element regardless of whether or not it is due for inspection.

Air Cleaner Indicator Light

→ Refer to page 4-41

Maintenance Schedule

→ Refer to page 7-159

Changing the Air Cleaner Element

1. Unfasten the 3 clips and remove the air cleaner cover.

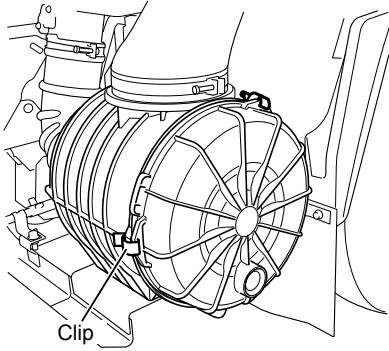

2. Remove the air cleaner element by pulling it out toward you.

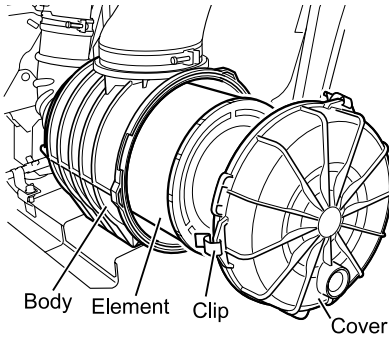

3. Remove the dirt that has accumulated on the air cleaner cover and the air cleaner body.
4. Clean the drain valve at the bottom of the air cleaner.

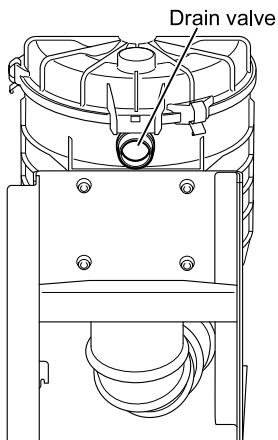

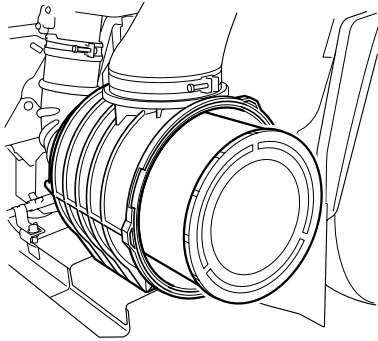

5. Push the element back into position in the air cleaner body.

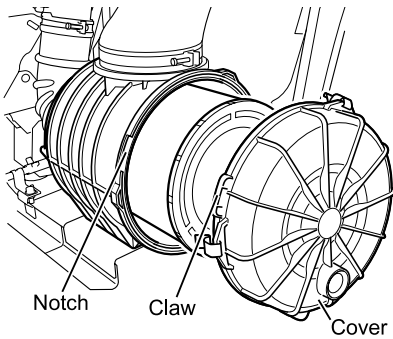

6. Install the air cleaner cover.
Line up the notch on the left side of the body with the claw on the cover.
Secure the cover in position by fastening the 3 clips.

Cleaning the Air Cleaner Element



Choose one of the following cleaning methods depending on how the element has become dirty.

1. When dry dust has adhered to the element
 - a. Blow compressed air at a pressure of up to **690 kPa (7.0 kgf/cm²/100 psi)** against the inside of the element while turning it to remove the dust.
 - b. Check to see if the element has been damaged or become thin in places.
2. When the element has become blackened by oily smoke or soot
 - a. Soak the element in a mixture of water and neutral detergent for about 30 minutes.
 - b. Remove the element from the detergent solution and rinse well using tap water.
 - c. After cleaning, allow the element to dry naturally in a well-ventilated place.

**ADVICE**

- Do not hit or strike the element, as this might damage it.
- Air drying will take 2 or 3 days. We recommend using a spare element.

Fuel Filter

Change the fuel filter in accordance with the Maintenance Schedule.
Drain the water when the water separator (fuel filter) warning light comes on.

Maintenance Schedule

→ Refer to page 7-159

Water Separator (Fuel Filter) Warning Light

Model without multi-information display (MID)

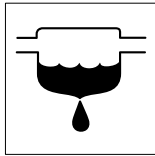

When a certain amount of water has collected in the water separator, the water separator (fuel filter) warning light comes on.

When this happens, drain the water and make sure that the warning light has gone out.

Model with MID



CAUTION

- Water remaining that is not discharged from the water separator could freeze and damage the vehicle.
- If the warning light comes on while the engine is in operation, immediately drain the water from the water separator (fuel filter). Continuing to drive with the light remaining on could damage the fuel injection pump. If this happens, have the vehicle checked and serviced by the nearest Isuzu Dealer.

Draining Water from the Fuel Filter

→ Refer to page 7-55

Changing the Fuel Filter

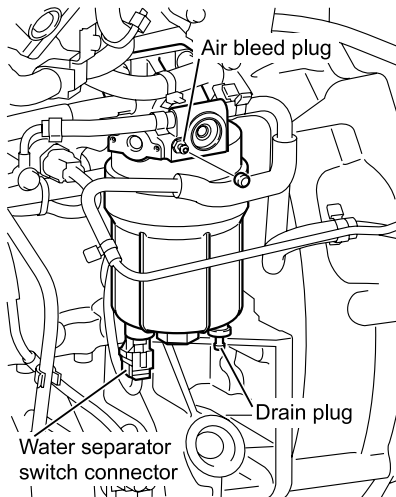

1. Loosen the drain plug at the bottom of the filter element case. Remove the rubber cap of the air bleed plug and then loosen the plug. This will allow the fuel in the filter element case to drain through the drain plug. Tighten the air bleed plug.
2. Disconnect the water separator switch connector.
3. Use a tool (like a 29 mm (1.14 in) socket wrench) to turn the hexagonal part at the bottom of the element case counterclockwise and remove the element case.

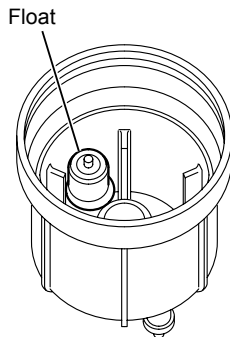

ADVICE

- Check the float at the bottom of the interior of the filter element case for free and smooth movement.
- Connect the water separator switch connector, turn the filter element case upside down, and confirm that the water separator (fuel filter) warning light comes on.
- Clean any foreign matter or dirt at the bottom inside the filter element case.

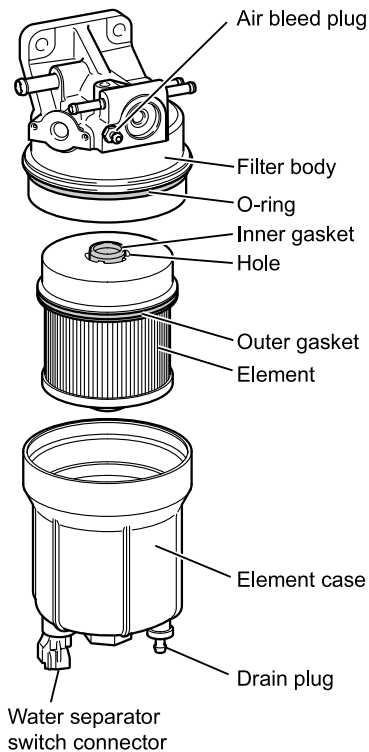

4. Pull out the filter element downward and remove the O-ring. Use a clean cloth to wipe off any foreign matter that has accumulated on the inside surface of the filter body.

**ADVICE**

- Do not use compressed air to remove foreign matter. Use a clean cloth instead. Air blowing may bring foreign matter into the fuel passage, which could cause the engine to malfunction.

5. Attach the new O-ring to the filter body, making sure that it is not damaged by the screw threads.
6. After lightly coating the inner and outer gaskets of the new filter element with diesel fuel, insert the element until it touches the filter body.

**ADVICE**

- Do not allow foreign matter to get into the 4 holes next to the inner gasket.

7. After lightly coating the inner surface of the element case or the O-ring with diesel fuel, turn the element case clockwise until it touches the filter body.

If the element case end fails to touch the filter body, the filter element has not been inserted fully. Reinsert the element while turning it.

 **WARNING**

- When fitting the element case, be careful not to let the O-ring become caught in the screw threads. This could cause a fuel leak and start a fire.

 **ADVICE**

- Be sure to use an Isuzu genuine fuel filter element.
- Replace the gaskets when replacing the filter element.
- Dispose of the replaced filter element in a method conforming to the regulatory requirements in your country.

8. Install the element case.

Element case tightening torque

30 - 36 N·m (3.1 - 3.7 kgf·m/22 - 27 lb·ft)

9. Tighten the drain plug and connect the water separator switch connector.

10. Bleed air from the fuel system.

Bleeding the Fuel System

→ Refer to page 8-15

 **WARNING**

- After changing the fuel filter element, operate the engine to check that there are no leaks around the filter. Fuel leaks could cause a fire.

Draining Water from the Fuel Filter

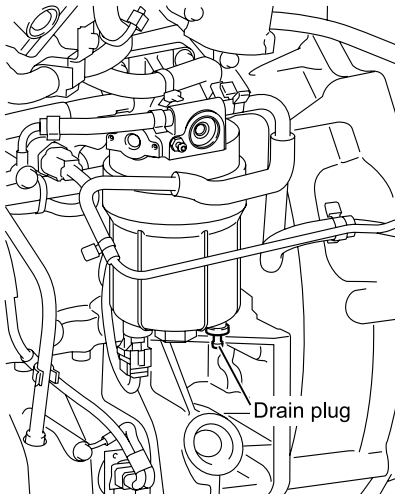

1. Attach a plastic hose to the drain plug on the bottom of the engine-side fuel filter and put the other end of the hose in a container placed beneath the filter.

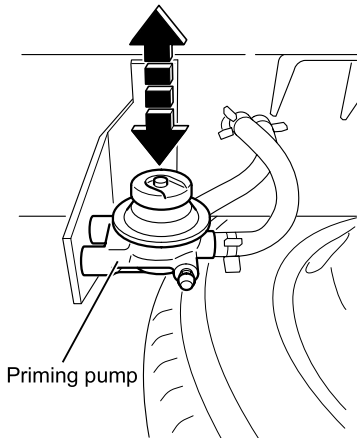

2. Loosen the drain plug and move the priming pump up and down by hand between 10 and 20 times.
3. Fully tighten the drain plug and move the priming pump several times.
4. Test run the engine and check that there are no fuel leaks from the drain plugs of the chassis-side fuel filter and engine-side fuel filter. Also check that the water separator (fuel filter) warning light stays off.



CAUTION

- Clean off any fuel that has adhered to the vehicle body.
- Starting the engine immediately after draining the water from the fuel filter requires a little more time than usual. If the engine doesn't start in 10 seconds, wait for a while and try again.
- Fuel will be mixed in the drained water. Dispose of it in a method conforming to the regulatory requirements in your country.

Diesel Particulate Defuser (DPD)

Checking and Cleaning the DPD

Have the exhaust pressure check performed at your Isuzu Dealer in accordance with the Maintenance Schedule. The filter may need cleaning depending on the results of the check. If you cannot do the exhaust pressure check, clean the filter and inspect the exhaust differential pressure sensor rubber.



CAUTION

- Failure to perform checks or cleaning of the DPD could result in a faulty DPD and engine damage, or poor fuel economy. Ask your Isuzu Dealer about checks and cleaning of the DPD.

Maintenance Schedule

→ Refer to page 7-159



NOTE

[Exhaust differential pressure sensor zero point adjustment]

- Every year, make a zero point adjustment for the exhaust differential pressure sensor that detects clogging in the DPD.
- Do not carry out a ZERO point adjustment of the exhaust differential pressure sensor within 2 hours after the DPD regeneration because of its sensitivity to heat.
- In addition, after every DPD inspection or DPD filter cleaning, make an exhaust differential pressure sensor adjustment according to the following procedure.

1. Turn the starter switch to the "ON" position, and leave it for a while. (Do not start the engine.)
2. Make sure that the DPD automatic regeneration indicator light and the DPD manual regeneration indicator light come on (model without multi-information display (MID)), or the "MANUAL REGEN." message and the "AUTO REGEN." message appear alternately (model with MID).
3. Make sure that the DPD automatic regeneration indicator light and the DPD manual regeneration indicator light go off in 30 seconds (model without MID), or the "MANUAL REGEN." message and the "AUTO REGEN." message go off in 30 seconds (model with MID).
4. Turn the starter switch to the "OFF" position, and leave it there for 15 seconds or more.

Notes



Notes

CHASSIS-RELATED SERVICE AND MAINTENANCE

• Brakes	7-60
• Parking Brake	7-70
• Brake Hoses and Pipes	7-72
• Disc Brakes <input type="checkbox"/> V	7-73
• Drum Brakes <input type="checkbox"/> V	7-75
• Wheels and Tyres	7-77
• Tyre Rotation	7-86
• Changing Tyres	7-88
• Spare Tyre <input type="checkbox"/> V	7-98
• Clutch <input type="checkbox"/> M/T	7-100
• Transmission Oil	7-105
• AMT Clutch Oil <input type="checkbox"/> SA	7-109
• Rear Axle Differential Gear Oil	7-112
• Front Axle Differential Gear Oil <input type="checkbox"/> V	7-114
• Transfer Gear Case Oil <input type="checkbox"/> V	7-117
• Power Steering Fluid	7-120
• Hub Bearing Grease	7-123
• Greasing Chassis Components	7-124

Brakes

Brake Fluid

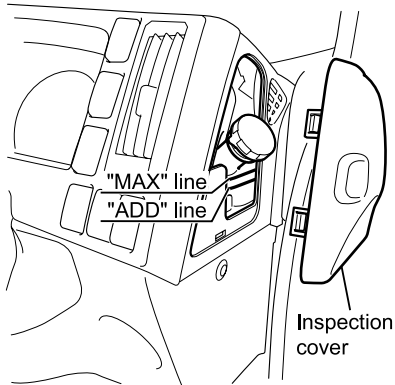

Checking the Brake Fluid Level

Remove the inspection cover on the driver side of the instrument panel by turning it with your fingers. Check that the fluid level in the reserve tank is between the "MAX" and "ADD" lines.

If the fluid surface cannot easily be seen, rock the vehicle gently.

Adding Brake Fluid

If the level of brake fluid has dropped below the "ADD" line, remove the cap and add fluid. Take care to avoid filling beyond the "MAX" line.

Tighten the cap securely after the fluid has been added.

CAUTION

- When adding fluid to the tank, take care to prevent dirt and water from entering it. Any dirt or water in the system could cause the vehicle to lose braking functions.
- Inspect and change brake fluid according to the Maintenance Schedule.
- Use non-petroleum base brake fluid when adding brake fluid.
- Be careful not to spill brake fluid onto painted surfaces or to let it come in contact with skin. If fluid is spilled onto a painted surface or come in contact with skin, wash away the fluid with water and immediately wipe the area clean.
- Brake fluid readily absorbs moisture. Therefore, it is necessary to close the container tightly for storage.
- Never mix the specified brake fluid with fluids of another brand.
- If the brake fluid level decreases rapidly, there may be a problem in the brake system or brake pads or shoe linings may have worn out. Have your vehicle inspected by the nearest Isuzu Dealer immediately.

Bleeding the Brake Hydraulic System

If air is present in the brake hydraulic system, it adversely affects brake operations. Bleed the system if the brakes are used when the quantity of the brake fluid in the tank is extremely low or the brake piping is removed during maintenance operation. Do not perform bleeding by yourself; it should be done with the help of another person. If the brake system is equipped with an LSPV, bleed air from the LSPV in addition to the front and rear brakes.

WARNING

- Before bleeding the brake system, be sure to park the vehicle on flat, level ground and apply chocks to the wheels.
- Since the brake fluid readily absorbs moisture, ensure that moisture does not enter the fluid while checking, adding or storing it. If moisture enters the fluid, the boiling point of the fluid decreases and this causes "vapor lock", a highly dangerous problem that affects brakes' functionality.
- Do not allow engine oil, gear oil and any other oils to mix with the brake fluid. Brake fluid contaminated with such oils degrades the brakes' functionality and damages the brake system components, possibly causing a very dangerous situation.

CAUTION

- Brake fluid melts paintwork and vehicle component materials such as plastic, vinyl and rubber. It is also highly corrosive on metals. If it is spilled, wipe it off the affected surface immediately and thoroughly wash the surface with water.
- When bleeding the brake hydraulic system (including the master and wheel cylinders) of a model with hydraulic brake booster (HBB), always start with bleeding of the hydro-booster system. Next, bleed the brake hydraulic system with the engine running. It is not possible to remove all the air while the engine is stopped.

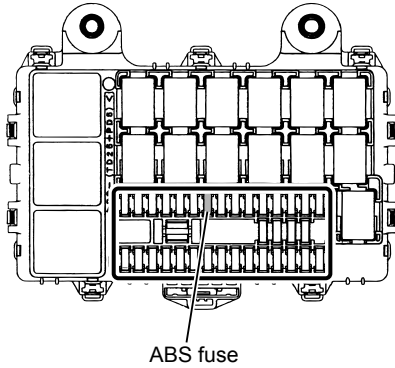

1. Fully apply the parking brake.

⚠ CAUTION

- In a model with an anti-lock brake system (ABS), remove the ABS fuse (10A) from the fuse box before starting an air-bleeding operation. Failure to observe this precaution will result in incomplete bleeding of air, and the ABS components may be damaged as a result. Once air bleeding has been completed, install the ABS fuse (10A) in its original position.

The Location of Fuses and Relays

→ Refer to page 8-37

2. Start the engine and allow it to idle.

⚠ CAUTION

- If the engine is not running during air bleeding, the brake booster may be damaged.

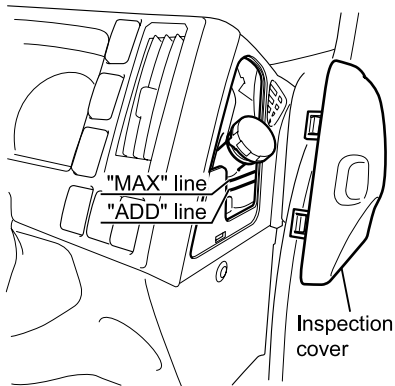

3. Remove the cap from the brake fluid tank, and then add brake fluid to the "MAX" level mark on the tank. Maintain this level throughout bleeding by adding brake fluid as necessary.
4. Bleed the brake hydraulic system part by part in the following sequence:
 Right-hand drive:
 Left rear wheel → Right rear wheel → LSPV (model with LSPV only) → Left front wheel → Right front wheel
 Left-hand drive:
 Right rear wheel → Left rear wheel → LSPV (model with LSPV only) → Right front wheel → Left front wheel

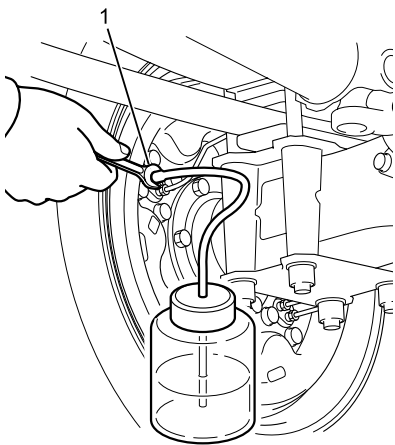

5. Detach the rubber cap from the bleeder screw (1). Wipe the bleeder screw clean. Attach one end of a vinyl tube to the bleeder screw and put the other end in a clear container. Fill the container with the brake fluid to about one-third (1/3) of its capacity.

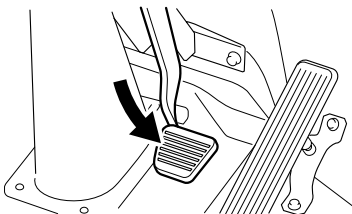

6. Press the brake pedal a few times and keep it pressed.

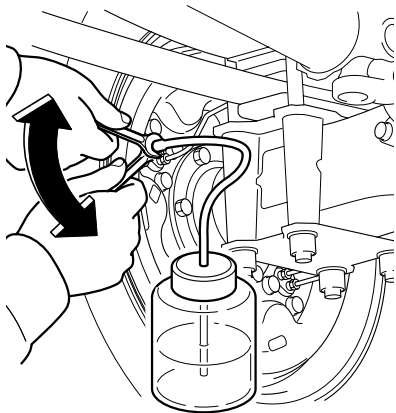

7. Loosen the bleeder screw to let the brake fluid containing air bubbles flow into the container and then tighten the bleeder screw immediately.

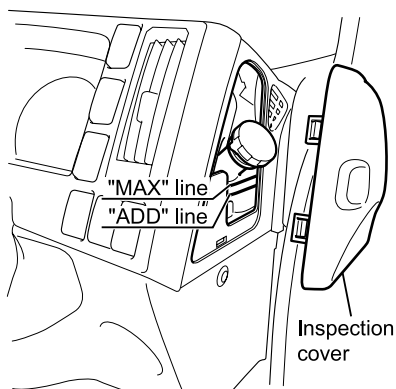

8. Release the brake pedal slowly. Repeat Steps 6 and 7 until the fluid from the tube no longer contains air bubbles. After bleeding, install the rubber cap in position.

**CAUTION**

- While bleeding, ensure that the fluid level in the brake fluid tank is not below the "ADD" line.
- If the engine is not running during air bleeding, the brake booster may be adversely affected.

Brake system warning light

9. After you finish the bleeding for each wheel, press the brake pedal to check that the brake system warning light does not come on.

Hydro-Booster Fluid  **WARNING**

- The HBB system has been designed to use Besco ATF-III as the hydro-booster fluid (DEXRON®III fluids from different suppliers can also be used). If any other fluid is used with this system, rubber components may be damaged, oil may leak and the system may malfunction. It is important to remember that the fluid used in the hydro-booster is completely different in characteristics from the brake fluid used in the master and wheel cylinders.
- Keep brake fluid for the master and wheel cylinders away from hydro-booster components. Likewise, keep hydro-booster fluid away from the master and wheel cylinder components.
- If hydro-booster fluid and brake fluid from the master cylinder are mistakenly mixed together and used, rubber components will deteriorate as a result of insufficient lubrication. Any resultant oil leakage or system malfunction can in turn lead to dragging brakes or other major brake problems. As such, mixing of these two fluids can ultimately lead to vehicle fire or other serious accidents.
- When the pump operates while the engine is running, the fluid in the hydro-booster will become hot. During normal braking, the temperature in piping and within the hydro-booster can rise above 100°C (212°F). For this reason, special care will be required when working with hydro-booster components. If the hydro-booster is to be removed from the vehicle, shut off the engine and then allow at least 30 minutes for it to cool down before beginning this operation.
- Even when the engine is stopped, the hydro-booster's accumulator will remain in a highly-pressurized condition for a significant period of time. Before removing the hydro-booster or piping from the vehicle, stop the engine and depress the brake pedal at least 10 times in order to lower the accumulator pressure to atmospheric pressure. This is of particular importance when removing components such as the accumulator or pressure switch from the hydro-booster. If these operations are attempted while the accumulator is still at a high pressure, hydro-booster fluid may spray out.

 **CAUTION**

- When bleeding the brake hydraulic system (including the master and wheel cylinders) of a model with HBB, always start with bleeding of the hydro-booster system. Next, bleed the brake hydraulic system with the engine running. It is not possible to remove all the air while the engine is stopped. When bleeding both the hydro-booster and the brake hydraulic systems, start with the hydro-booster system using Step 1 through Step 9 below.

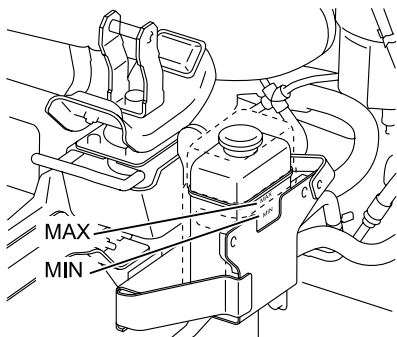

Checking the Hydro-booster Fluid Level

Check the hydro-booster fluid level and change the fluid according to the Maintenance Schedule.

The hydro-booster fluid level is correct if it is between the "MAX" and "MIN" lines. If the level is too low, add fluid up to the "MAX" line. Be sure to use Besco ATF-III when adding fluid.

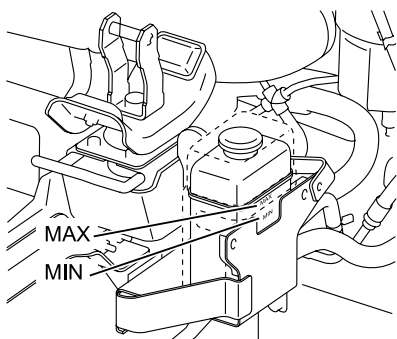

Changing the Fluid and Bleeding the Hydro-booster System

1. Add hydro-booster fluid until the level in the hydro-booster fluid tank is between the "MIN" and "MAX" marks.
2. Start the engine and allow it to idle for approximately 5 seconds.
3. Stop the engine and check the fluid level in the tank.
4. If the fluid level in the hydro-booster fluid tank is below the "MIN" mark, add fluid until it rises to between the "MIN" and "MAX" marks.
5. Repeat Step 2 through Step 4 until the fluid level has stabilized and no bubbles remain in the fluid. When bubbles are seen, wait until they have gone before repeating the above process.
6. With the engine running, slowly press the brake pedal about 5 times.
7. Stop the engine and check the fluid level in the tank. If the level is below the "MIN" mark, add hydro-booster fluid until it rises to between the "MIN" and "MAX" marks.
8. With the engine stopped, press the brake pedal at least 10 times.

9. Repeat Step 6 through Step 8 until the fluid level has stabilized and no bubbles remain in the fluid. When bubbles are seen, wait until they have gone before repeating the above process.
10. After completing Step 9, start the engine and bleed air from the brake hydraulic system (including the master and wheel cylinders) with the engine running.
11. With the engine running, slowly and firmly press the brake pedal approximately 30 times (at intervals of between 1 and 3 seconds) until the booster reaches the full-load range. Once the full-load condition has been reached, do not keep the pedal pressed for any more than 1 second.
12. Stop the engine, and then press the brake pedal at least 10 times in succession.
13. Check the condition of the hydro-booster fluid in the tank. The air-bleeding process can be ended when the fluid level has stabilized and bubbles are no longer present. When bubbles are seen, wait until they have gone and then perform Step 11 and Step 12 above again.

Brake Pedal

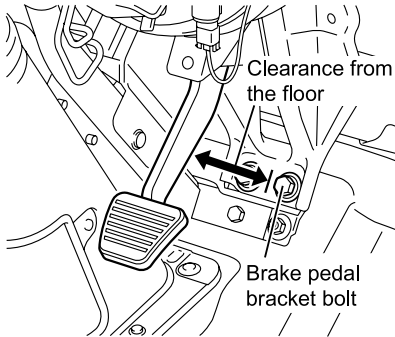
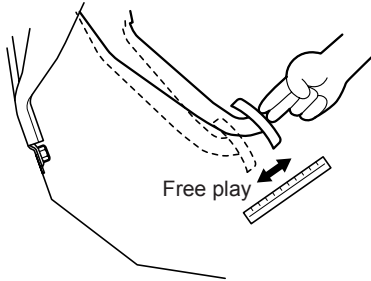

Stroke (Free Play)

Shut off the engine and depress the brake pedal about 10 times strongly, then check the brake pedal for free play by lightly pushing it by hand until you feel resistance. Next, start the engine, and wait at least 1 minute. Then depress the brake pedal and measure the clearance of the pedal from the floor (that is, the distance between the brake pedal bracket and the brake pedal arm).

Free play (measured at the tip of pedal)

Model without HBB	4 - 7 mm (0.16 - 0.28 in)
Model with HBB	24 - 29 mm (0.95 - 1.14 in)

Model without HBB	Clearance between the brake pedal and the brake pedal bracket with a pressure of 490 N (50 kgf/110 lb) applied to the brake pedal
Front disc brake and rear drum brake model	45 mm (1.77 in) or more
4-wheel disc brake model	25 mm (0.98 in) or more
4-wheel drum brake model with automatic adjuster	45 mm (1.77 in) or more
4-wheel drum brake model with manual adjuster (GVM: below 6,500 kg (14,332 lb))	55 mm (2.17 in) or more
4-wheel drum brake model with manual adjuster (GVM: 6,500 kg (14,332 lb) or more)	45 mm (1.77 in) or more

Model with HBB	Clearance between the brake pedal and the brake pedal bracket with a pressure of 294 N (30 kgf/66 lb) applied to the brake pedal
Front disc brake and rear drum brake model	35 mm (1.38 in) or more
4-wheel drum brake model	45 mm (1.77 in) or more

**ADVICE**

- If, after continued pressing of the brake pedal, the clearance slowly decreases or the pedal action feels spongy, air may be trapped in the brake hydraulic circuit. Have your vehicle inspected at the nearest Isuzu Dealer as soon as possible.
- If your vehicle's brakes squeak during normal driving or braking, the cause may be one of the following.
 - Brake pad wear
Brake pads are about to wear out. If this happens, have your vehicle inspected at the nearest Isuzu Dealer as soon as possible.
 - Adherence of sand, grit or mud
If sand, grit or mud adheres to the brakes, a screeching sound may be emitted upon contact with rotating components. If this happens, wash the vehicle to remove all such adhering matter. If cleaning alone does not eliminate the squeaking sound, have your vehicle inspected at the nearest Isuzu Dealer as soon as possible.

**NOTE**

- To check the clearance of the pedal from the floor, start the engine, depress the accelerator pedal a few times, and use the first pressing of the brake pedal to measure the clearance. The clearance cannot be correctly measured after pressing the pedal two or more times in succession.
- Before checking the free play of the brake pedal, stop the engine and press the pedal 4 or 5 times in succession.

Brake Performance

Run the vehicle slowly on a dry road and apply the brakes. Check that the brakes fully work and the vehicle does not pull on one side.

**CAUTION**

- A brake performance check should be performed on a wide road with good visibility while paying adequate attention to the traffic behind and the surroundings.

Parking Brake

Inspection

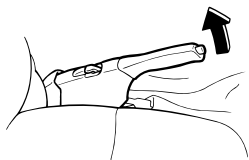

Pull the parking brake lever slowly from the fully released position while counting the clicks produced as the lever engages ratchet plate notches to check that it can be raised the proper amount and the lever is held firmly. Also, on a dry sloping road, check that the parking brake can hold the vehicle stationary.

Lever stroke*
6 to 8 notches

*Number of notches before parking brake is set when lever is pulled slowly from released position with pull force of about 147 N (15 kgf/33 lb)

Adjustments

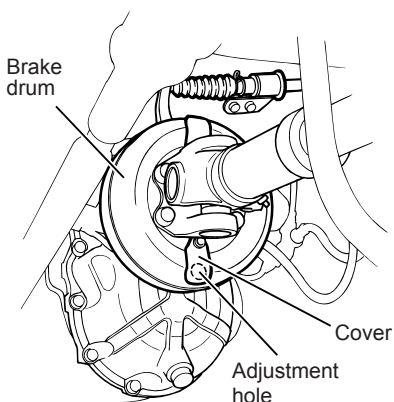

1. Park the vehicle on a level and flat ground surface, prevent the vehicle from moving by applying chocks to the front and back of the front wheels, and release the parking brake completely.
2. Loosen the parking brake lever cable adjusting nut inside the cab.
3. Confirm that the transmission is in the neutral position and then raise the vehicle with a jack until the rear wheels come clear of the ground.
4. Support the raised vehicle with jack stands.

Handling the Jack → Refer to page 7-128

WARNING

- Before going under the raised vehicle, make sure that the vehicle is securely supported with jack stands.
- If your vehicle is equipped with a differential lock system, limited slip differential (LSD) or non-spin differential, it might start moving when the engine power is transmitted to the rear axle even when one of the wheels on the axle is raised clear of the ground. Do not start the engine with any rear wheel in contact with the ground.

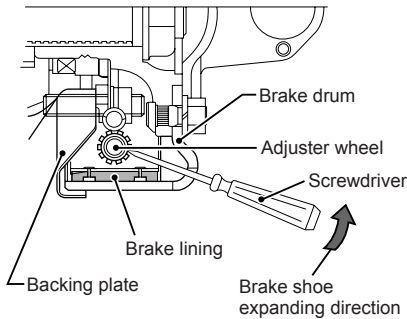

5. Turn the parking brake drum to place the adjustment hole straight down. Remove the adjustment hole cover and turn the drum as necessary to align the hole with the position of the adjuster wheel.
6. Insert a screwdriver through the adjustment hole and turn the adjuster wheel upwards until it cannot be turned any further.
7. From this point, turn the adjuster wheel back by the number of teeth indicated below. After the adjustment, reinstall the adjustment hole cover.

Vehicle model	Number of teeth by which the adjuster wheel should be turned back	Parking brake drum-to-lining clearance
MZZ transmission	8 teeth	0.23 mm (0.009 in)
MYY transmission	30 teeth	0.75 mm (0.029 in)

8. Turn the adjusting nut until the parking brake lever stroke is adjusted to a number of notches within the standard value range below. After the adjustment, securely tighten the lock nut.

Lever stroke
6 to 8 notches

Brake Hoses and Pipes

Inspection

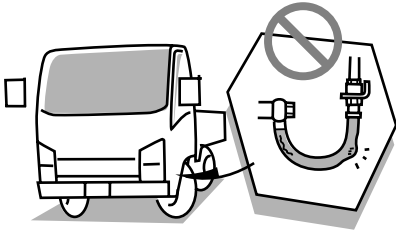

With the steering wheel turned fully to the left, check the left front brake hose and pipe visually and by touch, making sure that they are free of scratches, cracks and bulging. Also make sure that the hose and pipe do not interfere with any chassis part or wheel, and that their joints are not leaking and free of any type of damage. Check the right front brake hose and pipe in the same way. The rear left and right brake hoses and pipes should also be checked.

Disc Brakes V

If the brake pads wear out beyond their usable limit, not only will the brake performance be impaired, but brake components could also fail.

WARNING

- Do not drive with brake pads worn out beyond the limit. Excessively worn brake pads may cause breakdown of brake components and poor braking performance. This is very dangerous.

ADVICE

- The pad has an embedded wear indicator. A squeaking noise from the indicator means that the pad is approaching the usable limit. If the squeaking noise from the indicator can be heard, contact the nearest Isuzu Dealer for inspection or replacement.

Checking the Brake Rotor and Pads for Wear – Front and Rear Disc Brakes

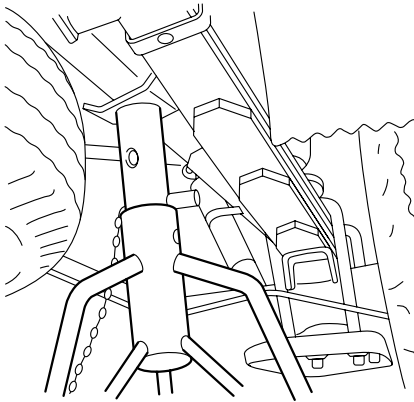

Removal

1. Apply the parking brake firmly and chock the wheels.

Parking Brake Lever

→ Refer to page 4-77

2. Raise the vehicle until the wheel is completely clear of the ground.
3. Support the raised vehicle with jack stands.
4. Remove the wheel.

Removing a Wheel

→ Refer to page 7-91

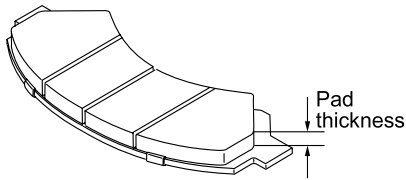

5. Check the pad and rotor as follows:
Measure the pad thickness, rotor thickness and rotor runout.

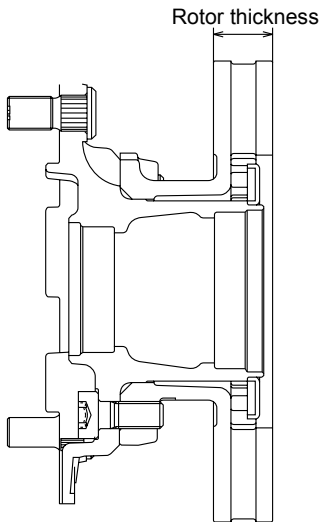

Brake size (Diameter x Thickness)	Rotor thickness		Pad thickness	
	Standard value	Usable limit	Standard value	Usable limit
φ265 x 35 mm (10.43 x 1.38 in)	35.0 mm (1.378 in)	33.0 mm (1.299 in)	14.0 mm (0.551 in)	1.0 mm (0.04 in)
φ285 x 35 mm (11.22 x 1.38 in)	35.0 mm (1.378 in)	33.0 mm (1.299 in)	14.0 mm (0.551 in)	1.0 mm (0.04 in)
φ293 x 40 mm (11.54 x 1.57 in)	40.0 mm (1.575 in)	37.0 mm (1.457 in)	13.0 mm (0.511 in)	1.0 mm (0.04 in)
φ310 x 42 mm (12.20 x 1.65 in)	42.0 mm (1.653 in)	39.0 mm (1.535 in)	13.0 mm (0.511 in)	1.0 mm (0.04 in)
φ363 x 42 mm (14.29 x 1.65 in)	42.0 mm (1.653 in)	39.0 mm (1.535 in)	13.0 mm (0.511 in)	1.0 mm (0.04 in)

Drum Brakes V

If the brake shoe linings wear out beyond their usable limit, not only will the brake performance be impaired, but brake components could also fail.

WARNING

- Do not drive with brake shoe linings worn out beyond the limit. Excessively worn brake shoe linings may cause breakdown of brake components and poor braking performance. This is very dangerous.

Brake Shoe Linings

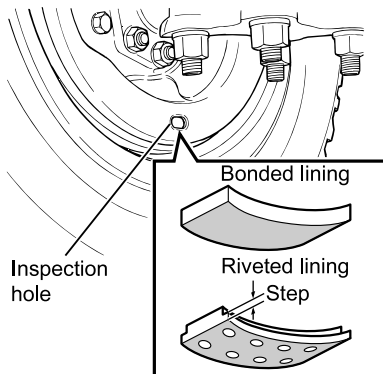

Checking Brake Shoe Linings for Wear

1. Remove the rubber plug from the inspection hole in the backing plate.
2. Check that brake shoe lining of sufficient thickness is remaining. Also check the side surfaces of the lining for cracks, flaking or other damage.
3. The wear limit for bonded brake shoe linings is when the thickness is reduced to 1 mm (0.04 in) and the wear limit for riveted linings is when the step is worn away. The lining must be replaced if it is worn beyond the wear limit or there are cracks or flaking on the side surfaces. Have the replacement carried out by the nearest Isuzu Dealer.

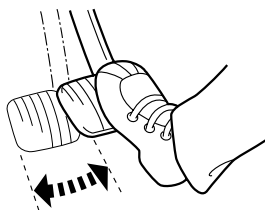

Adjustment of Drum-to-Lining Gap (Model with Automatic Adjuster)

1. Press down the brake pedal as far as it goes.
2. Repeating Step 1 above until there is no change in pedal stroke will automatically adjust the drum-to-lining gap to a certain extent. After this, repeated braking while driving will automatically adjust the gap.

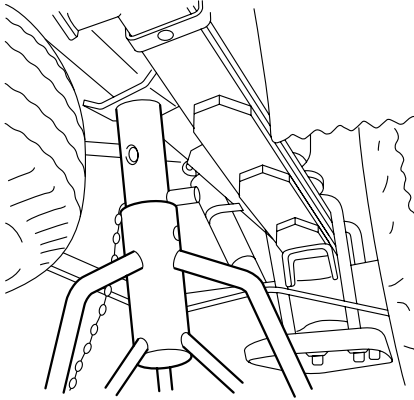

Adjustment of Drum-to-Lining Gap (Model without Automatic Adjuster)

1. Apply the parking brake firmly and chock the wheels.
2. Raise the vehicle until the wheel is completely clear of the ground.
3. Support the raised vehicle with jack stands.
4. Remove the rubber plug from the adjustment hole in the backing plate.
5. Insert a screwdriver into the adjustment hole and turn in the direction indicated by the arrow on the backing plate until the adjuster wheel can no longer be turned.
6. From this point, turn the adjuster wheel back by 5 or 6 teeth. After adjustment, install the adjustment hole's rubber plug in place.

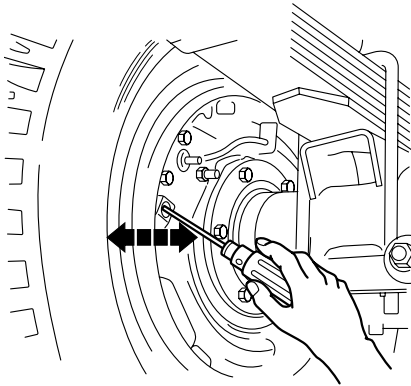

Wheels and Tyres

The wheels have a major influence upon the safety and comfort of driving. Should any wheel fall off the vehicle, it not only causes the vehicle to break down on the road and block other traffic, but it may also lead to a serious accident. We strongly recommend that you check the wheels and tyres daily and maintain them in satisfactory condition.

WARNING

- If you find anything abnormal with wheel bolts, wheel nuts or disc wheels when you check them, avoid driving the vehicle and contact the nearest Isuzu Dealer as soon as possible.
- If you find anything abnormal on the left wheels, check the right wheels carefully for similar defects. A defect on a wheel may be a sign of defects on other wheels.

Checking Tyres

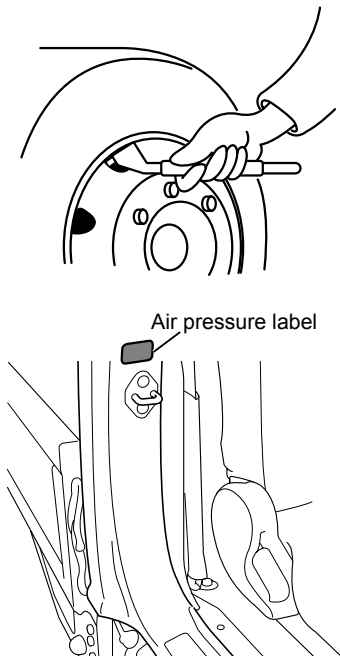

Air Pressure

Too low or too high a tyre air pressure not only affects the ride or causes damage to the cargo but also causes abnormal heat buildup, premature wear, a tyre puncture, or may even cause the tyre to burst.

- Use an appropriate tyre air pressure gauge when measuring the air pressure of a tyre. Tyre air pressure should be measured when the tyre is cold, or before the vehicle is driven. (After driving, tyre air pressure increases by about 10%.)
- As the tyre air pressure varies depending on the vehicle model and tyre size, refer to the air pressure label on the driver's door opening frame or the tyre air pressure tables on the following pages.
- Also check the air pressure of the spare tyre using a tyre air pressure gauge at the intervals specified by the Maintenance Schedule.

Tyre Air Pressure

Vehicle model	Tyre size		Tyre air pressure kPa (kgf/cm ² /psi)	
	Front	Rear	Front	Rear
NLR	195/75R16C	195/75R16C	475 (4.75/69)	475 (4.75/69)
NMR85H	7.00R15-8PR	7.00R15-8PR	450 (4.50/65)	450 (4.50/65)
	7.00-15-10PR	7.00-15-10PR	500 (5.00/73)	500 (5.00/73)
	7.00R15-10PR	7.00R15-10PR	525 (5.25/76)	525 (5.25/76)
	7.00-16-8PR	7.00-16-8PR	425 (4.25/62)	425 (4.25/62)
	7.00-16-10PR	7.00-16-10PR	500 (5.00/73)	500 (5.00/73)
	7.00R16-10PR	7.00R16-10PR	525 (5.25/76)	525 (5.25/76)
	7.00-16-14PR	7.00-16-14PR	725 (7.25/103)	725 (7.25/103)
	195/75R16C	195/75R16C	475 (4.75/69)	475 (4.75/69)
	195/85R16	195/85R16	600 (6.00/87)	600 (6.00/87)
	205/75R16C	205/75R16C	475 (4.75/69)	475 (4.75/69)
205/85R16	205/85R16	600 (6.00/87)	600 (6.00/87)	
NNR85F	195/75R16C	195/75R16C	475 (4.75/69)	475 (4.75/69)
	195/85R16	195/85R16	600 (6.00/87)	600 (6.00/87)
	215/75R17.5	215/75R17.5	600 (6.00/87)	600 (6.00/87)
NNR85H	195/85R16	185/80R15	600 (6.00/87)	450 (4.50/64)
	195/85R16	195/85R16	600 (6.00/87)	600 (6.00/87)
	195/75R16C	195/75R16C	475 (4.75/69)	475 (4.75/69)
	215/75R17.5	215/75R17.5	600 (6.00/87)	600 (6.00/87)
NPR75F	7.50-16-10PR	7.50-16-10PR	525 (5.25/76)	525 (5.25/76)
	7.50R16-10PR	7.50R16-10PR	575 (5.75/83)	575 (5.75/83)
	7.50-16-12PR	7.50-16-12PR	600 (6.00/87)	600 (6.00/87)
	7.50R16-12PR	7.50R16-12PR	650 (6.50/94)	650 (6.50/94)
	7.50-16-14PR	7.50-16-14PR	650 (6.50/94)	650 (6.50/94)
	7.50R16-14PR	7.50R16-14PR	700 (7.00/102)	700 (7.00/102)
	195/85R16	195/85R16	600 (6.00/87)	600 (6.00/87)
	215/85R16	215/85R16	600 (6.00/87)	600 (6.00/87)
	225/85R16	225/85R16	600 (6.00/87)	600 (6.00/87)
	215/75R17.5	215/75R17.5	600 (6.00/87)	600 (6.00/87)

Vehicle model	Tyre size		Tyre air pressure kPa (kgf/cm ² /psi)	
	Front	Rear	Front	Rear
NPR75H	7.50-16-10PR	7.50-16-10PR	525 (5.25/76)	525 (5.25/76)
	7.50R16-10PR	7.50R16-10PR	575 (5.75/83)	575 (5.75/83)
	7.50-16-12PR	7.50-16-12PR	600 (6.00/87)	600 (6.00/87)
	7.50R16-12PR	7.50R16-12PR	650 (6.50/94)	650 (6.50/94)
	7.50-16-14PR	7.50-16-14PR	650 (6.50/94)	650 (6.50/94)
	7.50R16-14PR	7.50R16-14PR	700 (7.00/102)	700 (7.00/102)
	195/85R16	195/85R16	600 (6.00/87)	600 (6.00/87)
	215/85R16	215/85R16	600 (6.00/87)	600 (6.00/87)
	205/75R17.5	205/75R17.5	750 (7.50/109)	750 (7.50/109)
	215/75R17.5	215/75R17.5	600 (6.00/87)	600 (6.00/87)
NPR75K	7.50-16-10PR	7.50-16-10PR	525 (5.25/76)	525 (5.25/76)
	7.50R16-10PR	7.50R16-10PR	575 (5.75/83)	575 (5.75/83)
	7.50-16-12PR	7.50-16-12PR	600 (6.00/87)	600 (6.00/87)
	7.50R16-12PR	7.50R16-12PR	650 (6.50/94)	650 (6.50/94)
	7.50-16-14PR	7.50-16-14PR	650 (6.50/94)	650 (6.50/94)
	7.50R16-14PR	7.50R16-14PR	700 (7.00/102)	700 (7.00/102)
	215/85R16	215/85R16	600 (6.00/87)	600 (6.00/87)
	225/85R16	225/85R16	600 (6.00/87)	600 (6.00/87)
	215/75R17.5	215/75R17.5	600 (6.00/87)	600 (6.00/87)
NPR75L	7.50-16-10PR	7.50-16-10PR	525 (5.25/76)	525 (5.25/76)
	7.50R16-10PR	7.50R16-10PR	575 (5.75/83)	575 (5.75/83)
	7.50-16-12PR	7.50-16-12PR	600 (6.00/87)	600 (6.00/87)
	7.50R16-12PR	7.50R16-12PR	650 (6.50/94)	650 (6.50/94)
	7.50-16-14PR	7.50-16-14PR	650 (6.50/94)	650 (6.50/94)
	7.50R16-14PR	7.50R16-14PR	700 (7.00/102)	700 (7.00/102)
	205/75R17.5	205/75R17.5	750 (7.50/109)	750 (7.50/109)
	215/75R17.5	215/75R17.5	600 (6.00/87)	600 (6.00/87)
NPR75M	215/75R17.5	215/75R17.5	600 (6.00/87)	600 (6.00/87)

Vehicle model	Tyre size		Tyre air pressure kPa (kgf/cm ² /psi)	
	Front	Rear	Front	Rear
NPR85F	7.00-16-10PR	7.00-16-10PR	500 (5.00/73)	500 (5.00/73)
	7.00R16-10PR	7.00R16-10PR	525 (5.25/76)	525 (5.25/76)
	7.00-16-12PR	7.00-16-12PR	575 (5.75/83)	575 (5.75/83)
	7.50-16- 8PR	7.50-16- 8PR	425 (4.25/62)	425 (4.25/62)
	7.50-16-10PR	7.50-16-10PR	525 (5.25/76)	525 (5.25/76)
	7.50-16-12PR	7.50-16-12PR	600 (6.00/87)	600 (6.00/87)
	7.50R16-12PR	7.50R16-12PR	650 (6.50/94)	650 (6.50/94)
	195/85R16	195/85R16	600 (6.00/87)	600 (6.00/87)
NPR85H	7.00-16-10PR	7.00-16-10PR	500 (5.00/73)	500 (5.00/73)
	7.00R16-10PR	7.00R16-10PR	525 (5.25/76)	525 (5.25/76)
	7.00-16-12PR	7.00-16-12PR	575 (5.75/83)	575 (5.75/83)
	7.50-16- 8PR	7.50-16- 8PR	425 (4.25/62)	425 (4.25/62)
	7.50-16-10PR	7.50-16-10PR	525 (5.25/76)	525 (5.25/76)
	7.50-16-12PR	7.50-16-12PR	600 (6.00/87)	600 (6.00/87)
	7.50R16-12PR	7.50R16-12PR	650 (6.50/94)	650 (6.50/94)
	195/75R16C	195/75R16C	475 (4.75/69)	475 (4.75/69)
	195/85R16	195/85R16	600 (6.00/87)	600 (6.00/87)
	205/85R16	205/85R16	600 (6.00/87)	600 (6.00/87)
	215/75R16C	215/75R16C	525 (5.25/76)	525 (5.25/76)
	215/75R17.5	215/75R17.5	600 (6.00/87)	600 (6.00/87)
225/85R16	225/85R16	600 (6.00/87)	600 (6.00/87)	
NPR85K	7.00-16-10PR	7.00-16-10PR	500 (5.00/73)	500 (5.00/73)
	7.00R16-10PR	7.00R16-10PR	525 (5.25/76)	525 (5.25/76)
	7.00-16-12PR	7.00-16-12PR	575 (5.75/83)	575 (5.75/83)
	7.50-16- 8PR	7.50-16- 8PR	425 (4.25/62)	425 (4.25/62)
	7.50-16-10PR	7.50-16-10PR	525 (5.25/76)	525 (5.25/76)
	7.50-16-12PR	7.50-16-12PR	600 (6.00/87)	600 (6.00/87)
	7.50R16-12PR	7.50R16-12PR	650 (6.50/94)	650 (6.50/94)
	195/85R16	195/85R16	600 (6.00/87)	600 (6.00/87)
	215/75R16C	215/75R16C	525 (5.25/76)	525 (5.25/76)
	215/75R17.5	215/75R17.5	600 (6.00/87)	600 (6.00/87)
	225/85R16	225/85R16	600 (6.00/87)	600 (6.00/87)
NPS	8.5R17.5	8.5R17.5	625 (6.25/91)	625 (6.25/91)

Vehicle model	Tyre size		Tyre air pressure kPa (kgf/cm ² /psi)	
	Front	Rear	Front	Rear
NQR75H	7.50-16-14PR	7.50-16-14PR	650 (6.50/94)	650 (6.50/94)
	7.50R16-14PR	7.50R16-14PR	700 (7.00/102)	700 (7.00/102)
	8.25-16-12PR	8.25-16-12PR	500 (5.00/73)	500 (5.00/73)
	8.25-16-14PR	8.25-16-14PR	575 (5.75/83)	575 (5.75/83)
	225/70R19.5F	225/70R19.5F	660 (6.60/95)	660 (6.60/95)
NQR75K	7.50-16-14PR	7.50-16-14PR	650 (6.50/94)	650 (6.50/94)
	7.50R16-14PR	7.50R16-14PR	700 (7.00/102)	700 (7.00/102)
	8.25-16-12PR	8.25-16-12PR	500 (5.00/73)	500 (5.00/73)
	8.25-16-14PR	8.25-16-14PR	575 (5.75/83)	575 (5.75/83)
	215/75R17.5	215/75R17.5	600 (6.00/87)	600 (6.00/87)
NQR75L	7.50-16-10PR	7.50-16-10PR	525 (5.25/76)	525 (5.25/76)
	7.50R16-10PR	7.50R16-10PR	575 (5.75/83)	575 (5.75/83)
	7.50-16-12PR	7.50-16-12PR	600 (6.00/87)	600 (6.00/87)
	7.50R16-12PR	7.50R16-12PR	650 (6.50/94)	650 (6.50/94)
	7.50-16-14PR	7.50-16-14PR	650 (6.50/94)	650 (6.50/94)
	7.50R16-14PR	7.50R16-14PR	700 (7.00/102)	700 (7.00/102)
	8.25-16-12PR	8.25-16-12PR	500 (5.00/73)	500 (5.00/73)
	8.25-16-14PR	8.25-16-14PR	575 (5.75/83)	575 (5.75/83)
	215/75R17.5	215/75R17.5	600 (6.00/87)	600 (6.00/87)
	225/70R19.5	225/70R19.5	660 (6.60/95)	660 (6.60/95)
NQR75M	225/70R19.5F	225/70R19.5F	660 (6.60/95)	660 (6.60/95)

 **WARNING**

- Insufficiently inflated or worn-out tyres are highly dangerous as they easily skid and can even burst. Should they burst, the tyres may burn and this could cause a fire in the vehicle.
- If you drive on under-inflated or flat tyres, the wheel bolts will be placed under excessive stress. Under such conditions, the bolts may break and the wheel may detach from the vehicle, possibly causing an accident.

 **CAUTION**

- Over-inflated tyres result in a harsh ride and are likely to cause damage to the cargo. Under-inflated tyres build up heat and could burst. Always keep the tyres of your vehicle adjusted at the standard air pressures.

 **ADVICE**

- There should not be a difference in air pressure between the inside and outside tyres on a dual-tyre wheel.
- It is not easy to visually identify an under-inflated dual-wheel tyre or low aspect ratio tyre (aspect ratio at 70% or 75%). Always use a tyre air pressure gauge to check the air pressure of any tyre.
- If your vehicle is equipped with aluminum wheels, use an extension attached to the inner tyre valve together with a standard tyre air pressure gauge or use a special air pressure gauge when checking the air pressure of a dual-wheel's inner tyre. This facilitates checking.

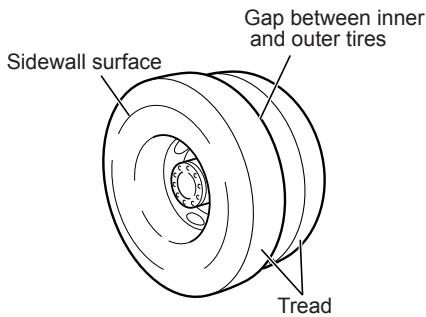

Cracks and Other Damage

Check the tread and sidewall surfaces of each tyre for cracks or other damage. Especially check the tread for nails or other metal pieces embedded in grooves and also the gap between the inner and outer tyres of a dual-tyre wheel for pebbles lodged in it.



ADVICE

- When checking tyres, pay special attention to: low air pressure; pebbles or nails in tread grooves; cracks or other damage on tyre surfaces; uneven wear; and pebbles lodged in the gap between tyres of dual-wheel tyres.

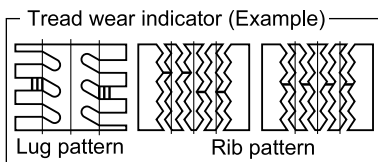
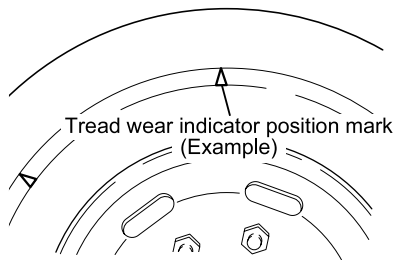

Tread Depth and Abnormal Wear

Using worn-out tyres is dangerous because they might have an increased chance of getting punctured or bursting while driving. Check all tyres to see if tread wear indicators appear on their treads and also check their entire tread for its depth with a depth gauge to make sure that the grooves are deeper than the specified depth.

A tyre with tread wear indicators appearing must be changed. Also, check the tyres for uneven or otherwise abnormal wear.



CAUTION

- Tyres with excessively shallow tread grooves will increase the chance of skidding and, when driving at high speeds, hydroplaning.



NOTE

- Hydroplaning occurs when a vehicle is running at high speeds on a wet road and a layer of water forms between the road surface and tyres causing the tyres to float on it. Hydroplaning prevents the driver from steering correctly and from slowing down the vehicle with the brake pedal.

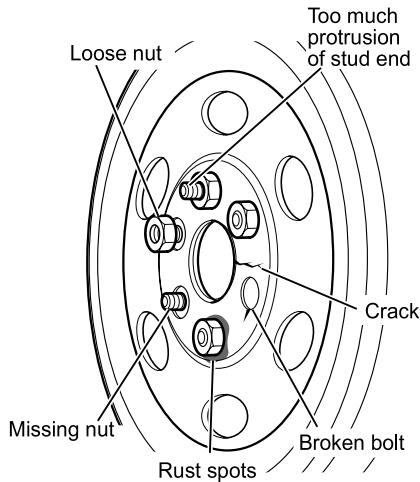

Visual Checking of Wheel Installation Condition

Visually check the condition of installation of each disc wheel.

1. Check that there are no missing wheel bolts and wheel nuts.
2. Check each disc wheel to see if there is any rust seepage from wheel bolts or nuts. Also check the disc wheel for cracks or other damage.
3. Check the end of each wheel stud for proper length of protrusion from the wheel nut. The protrusion should be uniform among all studs on a wheel and among all wheels.



CAUTION

- Any abnormality in wheel installation is likely to lead to loose or missing wheel nuts and/or broken wheel studs.

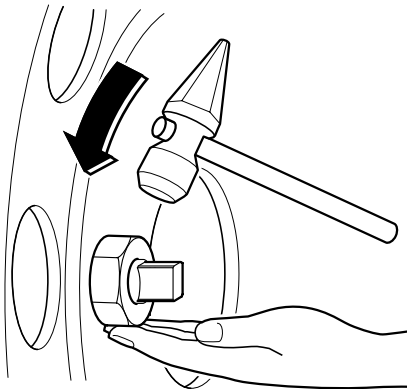

Checking Wheel Installation Condition with an Inspection Hammer

Place your fingers on the bottom of each wheel nut and tap the top flat portion of the nut with an inspection hammer or small hammer in the tightening direction.

There may be some defect in a nut or its stud if the vibration you feel by the fingers is different from the other nuts or if the sound it produces is not clear.



CAUTION

- If you detect any abnormal condition with a wheel nut and stud during this inspection, it is likely that the nut is loose or the stud is broken.

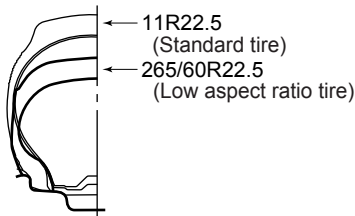
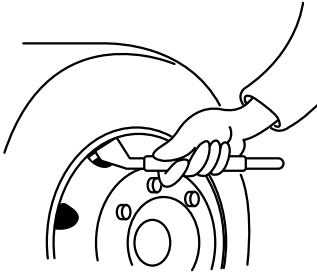

Spare Tyre Air Pressure

Keep the air pressure of the spare tyre slightly higher than the standard pressure. Adjust the pressure correctly when you use it.

Tyres heat up while driving, and their air pressures become higher accordingly. If you must wait until right after driving to adjust the air pressure, determine the target pressure for adjustment by adding about 20 kPa (0.2 kgf/cm²/3 psi) to the standard pressure.

Use of Low Aspect Ratio Tyres

Low aspect ratio tyres for truck applications (aspect ratio at 70% or 75%) have an air volume 20% to 30% smaller than that of standard tyres. When air begins to leak, therefore, low aspect ratio tyres adversely affect vehicle operation much faster than standard tyres. Check air pressure of low aspect ratio tyres more often than standard tyres using a tyre air pressure gauge.

Tyres Used for Long Term

Tyres are made of rubber whose property changes gradually by aging as time goes on (even when it is stored fitted on the rim like a spare tyre). Tyres must receive an aging check after being used for up to 5 to 7 years if they are to be used continuously.

Tyre Rotation



CAUTION

- Be sure to check the wheel studs, wheel nuts and disc wheel for any abnormality whenever the disc wheel is removed.
- If you find any abnormal condition on the wheel studs, wheel nuts or disc wheel, do not continue to use the wheel. Contact the nearest Isuzu Dealer as soon as possible.

Tyres at different locations wear differently. For uniform tyre wear and longer tyre life, you should rotate the tyres on your vehicle regularly.

Make sure to use tyres of the same type on the same axle. If you install tyres of different types on the same axle, the vehicle may drift right or left when you apply the brakes.

New tyres are more likely to build up heat and wear faster than old tyres, so they should be installed on the front axle where the load is smaller.

If there is a difference in diameter between the inner and outer tyres of a dual-tyre wheel, install the smaller diameter tyre inside.

The difference in diameter of the tyres for a dual-tyre wheel should be within the limit specified in the table below. If the limit is exceeded, the tyres wear more rapidly than they should.

[Single-wheel model]

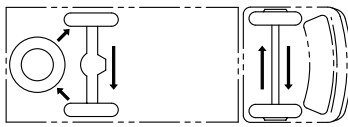

[Standard flat-low bed (manual transmission) model]

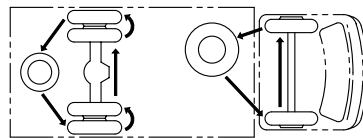

[Model with spare tyre stored at rear]

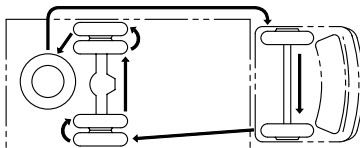

[Model with spare tyre stored at side]

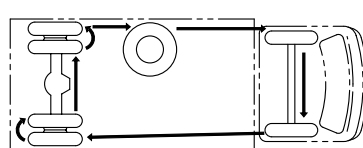

**CAUTION**

- If differently sized tyres are used between the front and rear axles, do not exchange tyres between the front and rear axles; otherwise, the tyres get loaded beyond their limits. This is highly dangerous because the tyres and disc wheels could be break down under an excessive load.

Permissible diameter difference

Radial tyre

Within 8 mm (0.31 in)

**ADVICE**

- The tightening torque of the wheel nuts may decrease after a tyre change due to their initial settlement. Upon driving 50 to 100 km (31 to 62 miles) after a tyre change, retighten the wheel nuts to the specified torques according to the instructions in the "Retightening Wheel Nuts" section in this chapter.

Retightening Wheel Nuts

→ Refer to page 7-94

Changing Tyres

Front
wheels

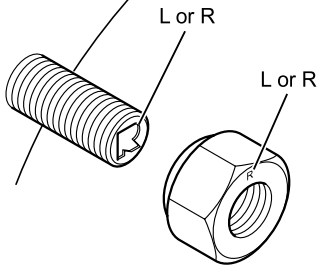

Change a tyre on a level and solid surface after checking safety in the surrounding area.

Handling the Jack → Refer to page 7-128

Every stud or nut for right-hand wheels is marked "R" or "R", and each stud or nut for left-hand wheels is marked "L" or "L".

Rear
wheels

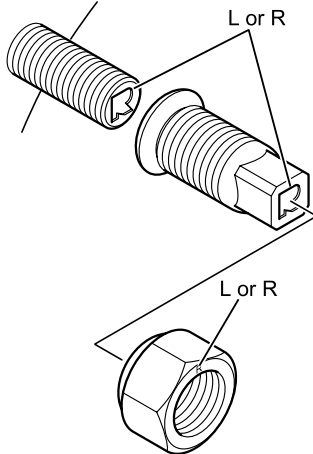

Preparation

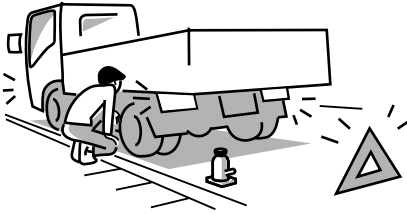

When you park the vehicle to change tyres, choose a place where

- Your vehicle does not hinder other traffic,
- The surface is level, flat and solid, and
- You can change a tyre safely.

When changing tyres on a road, use the hazard warning flasher and triangle reflectors to alert other traffic to the presence of your vehicle.

Fully pull the parking brake lever. Chock both the front and back sides of the wheel diagonally opposite to the one to be changed with chocks (or stones, wood blocks, etc.). (Example: When changing the right rear wheel, chock the left front wheel.) Have the passengers get out of the vehicle.



CAUTION

- If your vehicle is equipped with an anti-lock brake system (ABS), use a tyre of the specified size and the same tread pattern as the one to be replaced.

Removing a Wheel

WARNING

- Always apply the parking brake fully and correctly chock the wheels before raising the vehicle. Applying only the parking brake is insufficient to prevent the vehicle from moving. When a rear wheel is jacked up, the vehicle blocked only by the parking brake would move, creating a very dangerous situation.
- Never open doors or start the engine while jacking up the wheel. Do not try to look into the underside of the vehicle or get beneath the vehicle. This is very dangerous.
- To avoid danger in case of the jack slipping off, place the removed spare tyre near the jack under the vehicle.

CAUTION

- The wheel is heavy. Carefully handle it to avoid getting hurt when removing and installing the wheel.
- Do not touch the exhaust pipe just after stopping the vehicle; it is very hot. Do not change a tyre while diesel particulate defuser (DPD) regeneration is under way, as the exhaust temperature is very high at that time.

1. Firmly apply the parking brake. When changing a front wheel, chock the rear wheel diagonally opposite to the front wheel. When changing a rear wheel, chock the front wheel diagonally opposite to the rear wheel.
2. Firmly apply the head of the jack to the jacking point.
3. Raise the vehicle enough so that the tyre not quite clear of the ground.
4. Using the wheel nut wrench, loosen the wheel nuts just enough so that the wheel remains stable in position. Do not remove the wheel nuts yet.

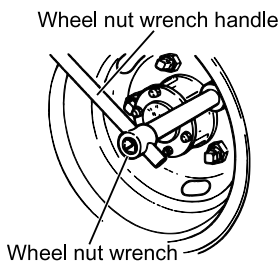

CAUTION

- Do not loosen the wheel nuts too much. The wheel studs would be damaged.

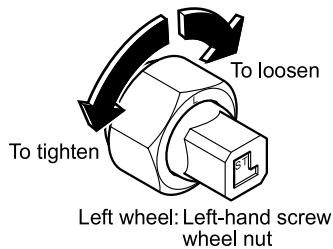
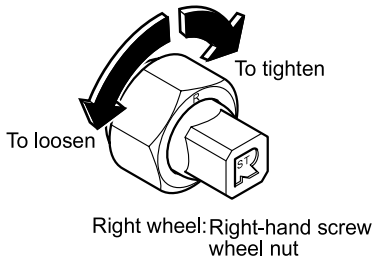

5. Jack up the vehicle so that the tyre is clear of the ground completely.
6. Remove all the wheel nuts that have been loosened, and then remove the wheel.
Remove the wheel being careful to not damage the threads of the wheel studs.
7. When removing either of the dual rear wheels, first remove the wheel nuts from the outer wheel and remove that wheel. Then, lower the vehicle and loosen the inner wheel nuts.
8. Raise the vehicle again, and then remove the inner wheel.
9. Check the following parts: the disc wheel for deformation and damage such as cracks; the hub for excessive wear of the disc wheel fitting surface; and the wheel studs and nuts for damage to the threads. If anything abnormal is found in the above parts, check other parts as well, and replace any defective part with a new one.

Front Wheel Jacking Points

→ Refer to page 7-130

Rear Wheel Jacking Points

→ Refer to page 7-131

Installing a Wheel

WARNING

- A disc wheel, wheel studs or wheel nuts in any abnormal condition could break later, causing the wheel to be detached from the vehicle while driving.
- Do not repaint any mating surfaces, wheel nut seating surfaces (tapered surfaces) and hub fitting surface of the disc wheel. Thick paint films would cause loosened or broken wheel studs.

CAUTION

- Change wheels only when the tyre is clear of the ground. Otherwise, the wheel will be installed improperly and the operation of the vehicle will be affected adversely.
- Remove mud and rust from the hub fitting surface or wheel-to-wheel mating surfaces. Otherwise, the wheel might become loose while driving.

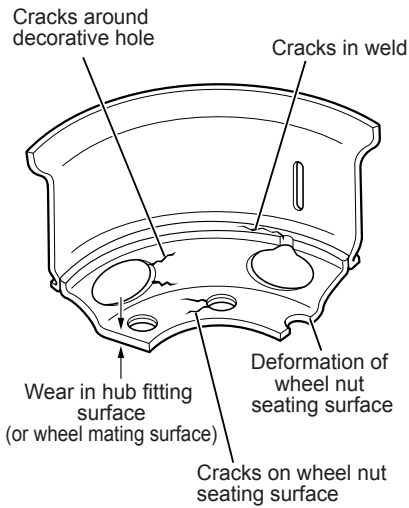

1. Check the disc wheel for the following:

- Cracks or other damage around the stud holes and decorative holes
- Cracks or other damage or deformation on the wheel nut seating surfaces (tapered surfaces)
- Cracks or other damage on welds
- Wear or other damage on the hub fitting surface or wheel-to-wheel mating surface

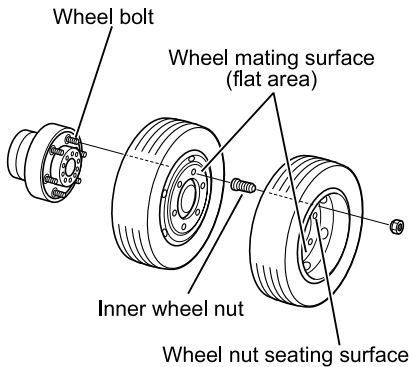

2. Check the wheel studs and wheel nuts for the following:

- Cracks or other damage
- Stud elongation or excessive rust
- Crushed, thinned or seized threads

CAUTION

- Remove rust and dirt from a wheel stud and nut, lightly lubricate the threads with engine oil, gear oil or power steering fluid and turn the nut on the stud. If the nut does not turn smoothly, the threads are defective.
- If the threads are defective, replace both wheel stud and wheel nut as a set.
- If any wheel stud is broken, change all the wheel studs and wheel nuts on the wheel.

3. Remove rust, dust and mud from the fitting surface, hub fitting surface or wheel-to-wheel mating surfaces, and wheel nut seating surfaces (tapered surfaces) of the disc wheel, and from the threads of the wheel studs and nuts.

CAUTION

- Clean the disc wheel to remove dirt and rust from its fitting surfaces, hub fitting surface or wheel-to-wheel mating surface. Also clean the tapered portion of each nut. If you fasten the wheel nuts without removing dirt and rust, the wheel nuts would later loosen and the wheel might be detached from the vehicle while driving. This could be very dangerous.

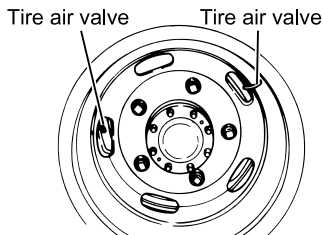

4. Install the wheel while aligning the stud holes in the disc wheel with the wheel studs.
When installing the rear wheel, place the outer wheel so that its tyre air valve will be 180 degrees apart from that of the inner wheel to enable inflating both inner and outer tyres.

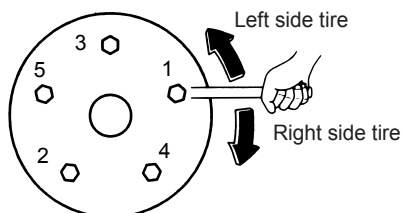
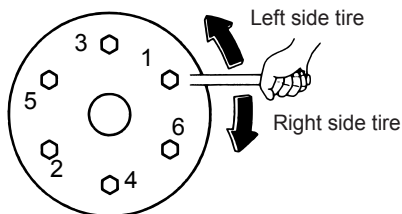
Wheel nut tightening sequence**Wheel with 5 nuts****Wheel with 6 nuts**

5. Screw in each wheel nut by hand until it touches the nut seating surface on the disc wheel, and then finger tighten all wheel nuts until the wheel is held in position without any looseness. Face the tapered end of wheel nuts inward.
6. Turn the bleeder screw of the jack counterclockwise to lower the vehicle slowly.
7. Tighten the wheel nuts in a diagonal sequence and in two or three passes. When installing a rear wheel, tighten the nuts of the inner wheel first and then the nuts of the outer wheel.

**CAUTION**

- Some impact wrenches available in the market produce torques higher than the maximum torque specified for tightening the wheel nuts. If the wheel nuts are tightened with such an impact wrench, wheel studs might be broken. Before using an impact wrench, check that the torque it produces conforms to the specification.
- When using an impact wrench, carefully adjust the air pressure regulator and select the tightening time. As a final step, tighten to the specified torque using a torque wrench.

8. Finally, tighten all wheel nuts using a torque wrench to the specified torque. You must tighten the nuts of the rear inner wheel before tightening the nuts of the rear outer wheel even when you change only the rear outer wheel.

Model or Specification	Front wheel nuts		Rear wheel nuts	
	Tightening torque	Quantity	Tightening torque	Quantity
Single Tyre	138 - 196 N·m (14 - 20 kgf·m/ 101 - 145 lb·ft)	6	138 - 196 N·m (14 - 20 kgf·m/ 101 - 145 lb·ft)	6
Dual Tyres	441 - 539 N·m (45 - 55 kgf·m/ 325 - 398 lb·ft)	5 or 6	441 - 539 N·m (45 - 55 kgf·m/ 325 - 398 lb·ft)	5 or 6



ADVICE

- After changing a tyre, turn the steering wheel in both directions to make sure that the wheels do not interfere with the surrounding components. If you are unclear about any of this, please contact the nearest Isuzu Dealer.
- The tightening torque of the wheel nuts may decrease after tyre replacement due to their initial settlement. Upon driving 50 to 100 km (31 to 62 miles) after a tyre change, retighten the wheel nuts to the specified torque according to the instructions in the "Retightening Wheel Nuts" section in this chapter.

Retightening Wheel Nuts

→ Refer to page 7-96

Retightening Wheel Nuts

Check the wheel nuts to make sure they are tightened to the specific torque by using a torque wrench.

Use the following methods to check loose wheel nuts. The tightening torque of the wheel nuts may decrease after a tyre change or rotation due to their initial settlement. After driving 50 to 100 km (31 to 62 miles), be sure to retighten the wheel nuts to the specified torque.

Model or Specification	Front wheel nuts		Rear wheel nuts	
	Tightening torque	Quantity	Tightening torque	Quantity
Single Tyre	138 - 196 N·m (14 - 20 kgf·m/ 101 - 145 lb·ft)	6	138 - 196 N·m (14 - 20 kgf·m/ 101 - 145 lb·ft)	6
Dual Tyres	441 - 539 N·m (45 - 55 kgf·m/ 325 - 398 lb·ft)	5 or 6	441 - 539 N·m (45 - 55 kgf·m/ 325 - 398 lb·ft)	5 or 6

Retightening of nuts on left rear dual-tyre wheel

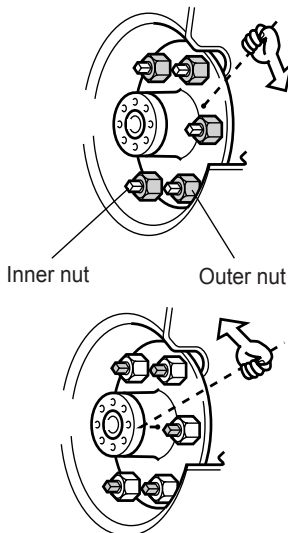

Single Tyre

Turn the wheel nuts in the tightening direction to the specified torque.

Dual Tyre

1. Of the nuts on the wheel studs, loosen the outer wheel nuts.
2. Tighten the inner wheel nuts of the same wheel to the specified torque.

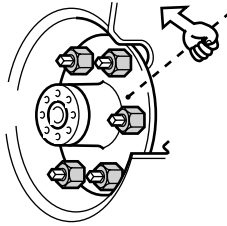

3. Next, tighten the outer wheel nuts to the specified torque.

**WARNING**

- If you find any abnormal conditions with the wheel nuts such as frequent loosening of retightened nuts, have your vehicle checked or serviced at the nearest Isuzu Dealer as soon as possible.

**CAUTION**

- Fully engage the wheel wrench on a wheel nut in order to tighten the nut to the specified torque. However, do not use a pipe as a handle extension or your foot to apply force on the wrench. This would tighten the nut more than required and might damage components.
- Both under-tightening and over-tightening of wheel nuts may cause broken wheel studs or cracked disc wheels and could lead to wheel detachment. Adhere to the specified tightening torques.
- When replacing a tyre with a new one, use only a tyre of the same type and size as the replaced tyre; otherwise, driving safety could be affected. Avoid mixed use of different types or different size tyres at all costs.

Spare Tyre v

Removal

Assemble the spare tyre removing bar and crank handle together, insert the bar into the hole in the spare tyre carrier, and turn the crank handle counterclockwise to remove the spare tyre.

Spare tyre stored at rear of frame

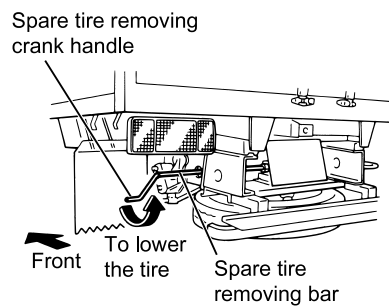
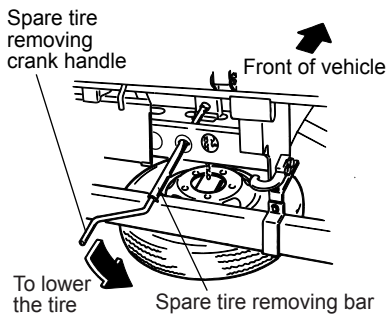

Spare tyre stored at side of frame

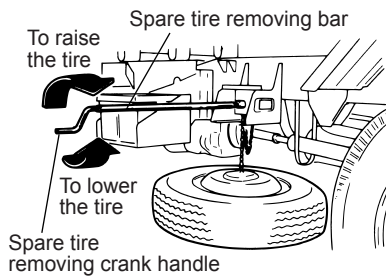

Storage

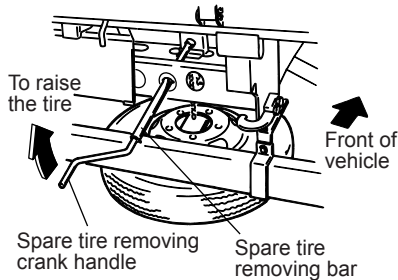

Store the spare tyre with the convex side of the disc wheel facing upward as shown in the figure. Insert the plate at the tip of the chain into the disc wheel centre hole and adjust its position for secure engagement with the spare tyre before winding the chain up.



CAUTION

- If the chain twisted when it is wound, it becomes loose while running due to vibrations or shocks and the tyre might fall off; this is very dangerous.
- After storing the tyre in the carrier, check that the tyre is held firmly. If loosely retained, the tyre becomes loose while running due to vibrations or shocks and the tyre might fall off; this is very dangerous.



ADVICE

- Turn the spare tyre removing bar clockwise to fully wind up the chain, apply at least **196 N (20 kgf/44 lb)** of force to the crank handle by hand, and make sure that the spare tyre is firmly secured in place.
- After storing the spare tyre, check that it is not loose by strongly pushing the tyre with your foot. If the tyre is loose, fasten it again after checking that there are no defects in the carrier such as a bent bracket or hanger plate. If you cannot retighten the tyre in the carrier, do not drive the vehicle but contact the nearest Isuzu Dealer.

Air Pressure

Check the air pressure of the spare tyre using a tyre air pressure gauge at the intervals specified in the Maintenance Schedule.

A spare tyre inflated to a normal pressure may lose its pressure gradually over time due to leaks. You should therefore inflate it to a pressure a little higher than the normal over time pressure.

Maintenance Schedule

→ Refer to page 7-159

Clutch M/T

Clutch Fluid

CAUTION

- When refilling the tank with clutch fluid, be careful not to let dust or water enter the tank. Dust or water can impair clutch operation.
- Be careful not to spill clutch fluid on a painted surface or let it come in contact with your skin. Should the fluid be spilled on a painted surface or come in contact with your skin, wash away the fluid with water and immediately wipe the area clean.
- Use only the specified clutch fluid and change it according to the Maintenance Schedule.
- Clutch fluid readily absorbs moisture. Close the cap of the container tightly when storing it.
- Do not use clutch fluid mixed with that of any other brand.
- If clutch fluid decreases too rapidly, there might be a problem in the clutch system or the clutch disc might be worn beyond safe limit. Have your vehicle inspected by the nearest Isuzu Dealer immediately.

Maintenance Schedule

→ Refer to page 7-159

Recommended Fluids, Lubricants and Diesel Fuels

→ Refer to page 7-172

Checking the Clutch-Fluid Level

Remove the inspection cover on the driver side of the instrument panel by turning it with your fingers.

Confirm that the fluid level in the reserve tank is between the "MAX" and "ADD" lines.

If the fluid surface cannot easily be seen, rock the vehicle gently.

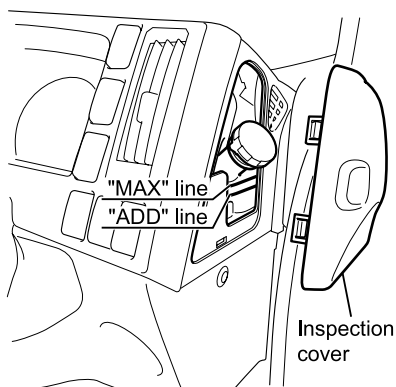

Adding Clutch Fluid

If the level of clutch fluid has dropped below the "ADD" line, remove the clutch fluid tank cap and add fluid. Add the specified clutch fluid up to the "MAX" line.



CAUTION

- Before refilling the tank, clean the area around the cap and fill clutch fluid from a clean container. Foreign objects getting in the tank will lead to a clutch system failure.
- Clutch fluid melts paintwork and vehicle component materials such as plastic, vinyl and rubber. It is also highly corrosive on metals. If it is spilled, immediately wipe the area clean or wash away the fluid with water.
- Do not mix clutch fluid with fluids of a non-specified brand. Due to chemical reactions, any mixture of differently branded fluids will cause failure of the clutch system.

Changing Clutch Fluid

Change the clutch fluid according to the Maintenance Schedule using the specified fluid. Since a clutch fluid change requires disassembly of the related components, have this service performed by your Isuzu Dealer.

Bleeding the Clutch Hydraulic System

If air is present in the clutch hydraulic system, the clutch may disengage incompletely. Bleed the system if the clutch is used when the quantity of the clutch fluid in the tank is extremely low or the clutch piping is disconnected during a maintenance operation. Do not perform bleeding by yourself; it should be done with the help of another person.

1. Chock the wheels and firmly apply the parking brake.
2. Check the level of the clutch fluid in the tank and add fluid as required.
3. Detach the rubber cap from the bleeder screw on the clutch slave cylinder. Wipe the bleeder screw clean.

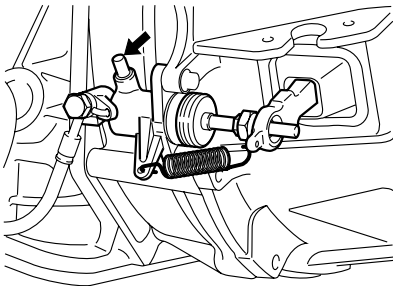

4. Attach one end of a vinyl tube to the bleeder screw and put the other end in a clear container. Fill the container with clutch fluid to about one-third (1/3) of its capacity.

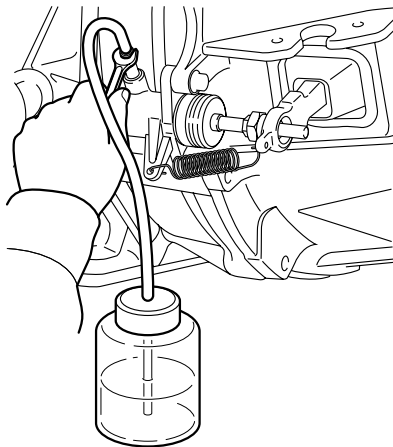

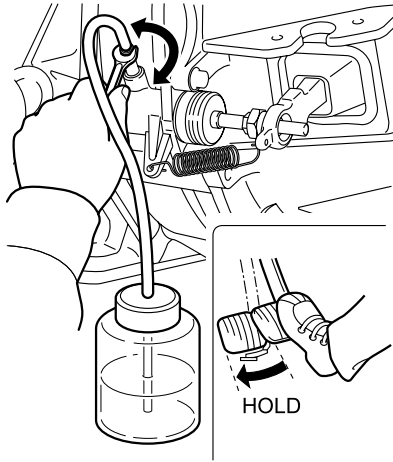

5. Press the clutch pedal several times and then keep it pressed.
6. Loosen the bleeder screw to let the clutch fluid containing air bubbles flow into the container and then tighten the bleeder screw immediately.
7. Release the clutch pedal slowly. Repeat Steps 5 and 6 until the fluid from the tube no longer contains air bubbles. After bleeding, install the rubber cap in position.

**CAUTION**

- While bleeding, ensure that the fluid level in the clutch fluid tank is not below the "MIN" mark.

Clutch Pedal

The clutch disc wears down as the clutch is used, and this causes the free play of the clutch pedal to decrease. If you continue to use the clutch with reduced clutch pedal play, the clutch slips easily. On the other hand, if the pedal free play is too much, the clutch disengages poorly, making gearshifts difficult.

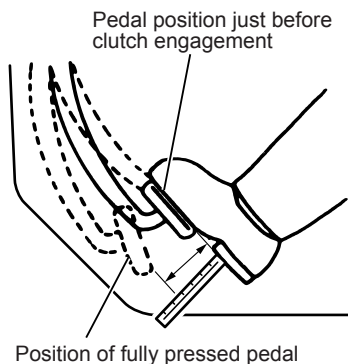
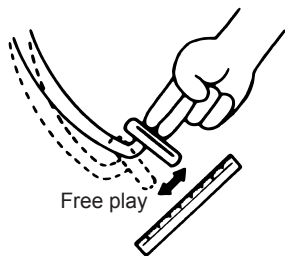

Checking the Clutch Pedal

1. Lightly press the clutch pedal by hand until you feel a slight resistance. The distance of the pedal movement to this point is the free play.

Clutch pedal free play
15 - 25 mm (0.59 - 0.98 in)

2. Make sure that the parking brake lever is pulled completely. Start and run the engine at idle and then press the clutch pedal fully.
3. Move the gearshift lever to the 1st position and then release the pedal slowly. The clutch pedal is normal if the distance from the fully pressed position to the position just before the clutch engages is 20 mm (0.79 in) or more.

Check also that the clutch engages smoothly without any slip when the vehicle starts to move slowly.



ADVICE

- Release the clutch pedal carefully to prevent the vehicle from starting too suddenly.

Transmission Oil

Change the transmission oil according to the Maintenance Schedule.

If your vehicle is equipped with AMT, you should follow the special procedures for level checking and changing of the AMT clutch oil.

Maintenance Schedule

→ Refer to page 7-159

AMT Clutch Oil SA

→ Refer to page 7-109



ADVICE

- Use the oil quantities indicated below only as guidelines when changing the transmission oil. After changing the oil, make sure the oil is at the required level.
- Drained oil must be disposed of in a method conforming to the regulatory requirements in your country.

Quantity of transmission oil to be changed

Transmission model		Oil quantity [Reference value]	Liter (US gal./Imp gal.)
		Without PTO	With PTO
MYY5T	5 speeds	2.8 (0.74/0.62)	3.1 (0.82/0.68)
MYY6S	6 speeds	3.5 (0.92/0.77)	3.8 (1.00/0.84)
MZZ6F/6U	6 speeds	4.4 (1.16/0.97)	5.3 (1.40/1.17)



NOTE

- The transmission model is indicated on the ID plate in the cab.

Option Codes → Refer to page 1-4

Checking the Oil Level

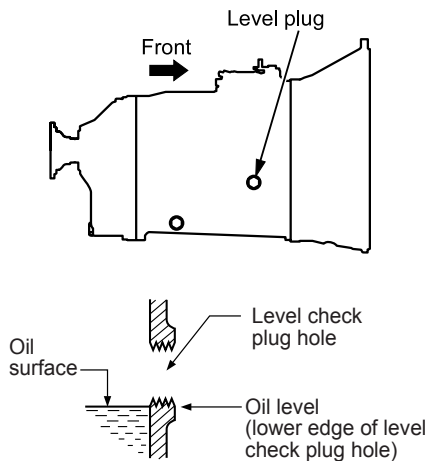

1. Remove the oil level plug.
2. Check whether the oil level is up to the lower edge of the oil level plug hole. The correct oil level range is between 0 and 10 mm (0 and 0.39 in) below the bottom of the level plug hole.

If the oil level is too low, add oil through the oil level plug hole.

3. Fasten the oil level plug to the specified torque.
Also check to see if there are any transmission oil leaks.

Oil level plug tightening torque

39 N·m (4.0 kgf·m/29 lb·ft)

**ADVICE**

- Any dirt on the plug should be wiped off before installing it.

Changing the Oil

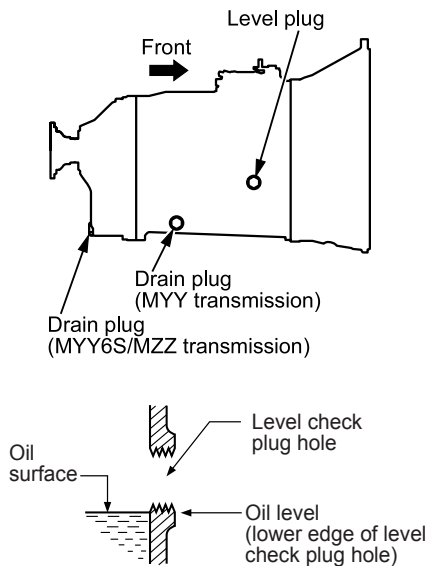

1. Place a container under the drain plug(s) to receive oil.
2. Remove both oil level plug and drain plug(s) to discharge the oil into the container.
3. After installing the drain plug(s) by tightening it to the specified torque, refill the transmission with new oil through the oil level plug hole up to the lower edge of the hole.

Drain plug tightening torque

39 N·m (4.0 kgf·m/29 lb·ft)

**ADVICE**

- The dirt on the plug should be wiped off before installing it.

4. After refilling, confirm that the oil level is up to the lower edge of the oil level plug hole.

5. Install the oil level plug by tightening it to the specified torque.

Oil level plug tightening torque

39 N·m (4.0 kgf·m/29 lb·ft)

**ADVICE**

- Any dirt on the plug should be wiped off before installing it.

**ADVICE**

- Because the cases of the MYY and MZZ transmissions are made of aluminum, be extremely careful not to tighten the oil level plug and drain plug to an excessively large torque when installing them. Otherwise, the threads might be damaged.

AMT Clutch Oil SA

Your vehicle, if equipped with a AMT system, needs a change of AMT clutch oil in addition to transmission oil.

Check and change the AMT clutch oil at intervals specified by the Maintenance Schedule.

**ADVICE**

- Both quality and quantity of oil are important factors that have a significant influence on the performance and durability of AMT. Be sure to use only the Isuzu recommended oil for replenishment, and observe the specified oil level.
 - Too much oil will cause oil leaks.
 - Too little oil will cause malfunction of the system.
- Before checking the AMT clutch oil level, thoroughly clean the dipstick and the area around it to prevent dust or other foreign matter from entering the system. Failure to do so may cause a fault in the transmission. Clean the dipstick before installing it as well.
- Do not let coolant, water or other oils mix with the transmission or AMT clutch oil. Otherwise, degraded performance and faulty operation of the system would result.

Maintenance Schedule

→ Refer to page 7-159

Recommended Fluids, Lubricants and

Diesel Fuels → Refer to page 7-172

Transmission Oil → Refer to page 7-105

Checking the Oil Level

Single cab model

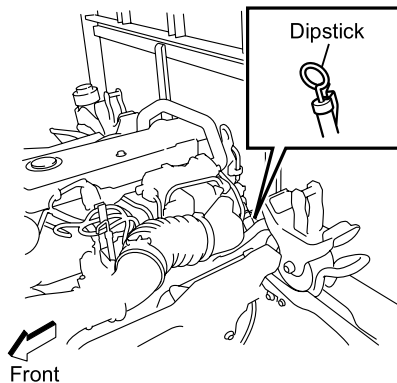

Crew cab model

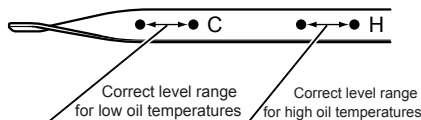
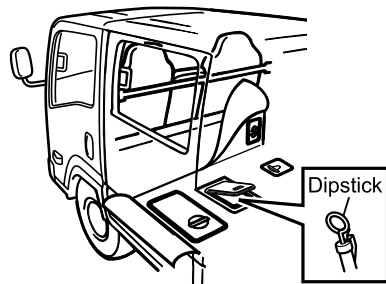

1. Park the vehicle on level ground, place the gearshift lever in the "N" position and firmly apply the parking brake.
2. Start the engine.
3. Pull out the dipstick and wipe it with a clean cloth.
4. Reinsert the dipstick into position and then, while the engine is running at idle, pull out the dipstick slowly and check whether the oil level is within the "C" marked range on the dipstick when the oil temperature is low, or within the "H" marked range when the oil temperature is high.
5. If the oil level is too low, add oil as necessary.
6. After checking, insert the dipstick fully into position.

Mark on dipstick	AMT clutch oil temperature
COLD (C)	About 20 - 30°C (68 - 86°F)
HOT (H)	About 70 - 80°C (158 - 176°F)



CAUTION

- Be extremely careful not to burn yourself when checking the oil level if the engine temperature is high. Protect yourself with gloves, etc.

Changing the Oil

Changing the AMT Clutch Oil

Change the AMT clutch oil according to the Maintenance Schedule.

Maintenance Schedule

→ Refer to page 7-159



ADVICE

- After changing the AMT clutch oil, check that the oil level is correct by following the instructions in the preceding "Checking the Oil Level" section.
- Drained oil must be disposed of in a method conforming to the regulatory requirements in your country.

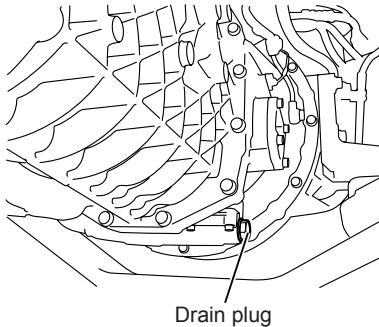

1. Place a container beneath the drain plug.
2. Tilt the cab.
3. Pull out the dipstick.
4. Remove the drain plug to discharge the oil into the container.



NOTE

- AMT clutch oil cannot be completely drained because a certain amount remains in the fluid coupling and hydraulic circuits.

5. Install the drain plug by tightening it to the specified torque.

Drain plug tightening torque

29 - 49 N·m (3.0 - 5.0 kgf·m/22 - 36 lb·ft)

6. Fill the clutch with new oil through the dipstick guide tube.
7. Check the oil level according to the "Checking the Oil Level" section.

Checking the Oil Level

→ Refer to page 7-110

Rear Axle Differential Gear Oil

The rear axle differential gear oil level must be checked for its level and it must be changed according to the Maintenance Schedule.



ADVICE

- Use the oil quantities indicated later in this section only as guidelines when changing the rear axle differential gear oil.
- After changing the oil, ensure that it is at the correct level.
- Drained oil must be disposed of in a method conforming to the regulatory requirements in your country.

Maintenance Schedule

→ Refer to page 7-159

Checking the Oil Level

1. Remove the oil level plug.

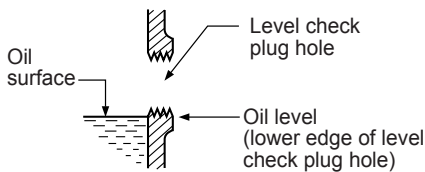
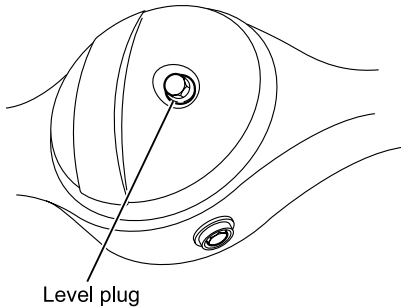

2. Check that the oil level is up to the lower edge of the oil level plug hole.
 - If the oil level is too low, add oil through the oil level plug hole.
3. Fasten the oil level plug to the specified torque.

Plug tightening torque

84 N·m (8.6 kgf·m/62 lb·ft)



ADVICE

- Any dirt on the plug should be wiped off before installing it.

Changing the Oil

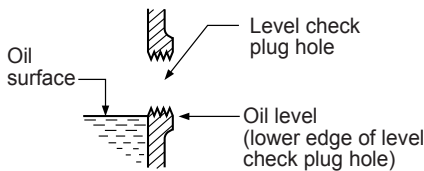
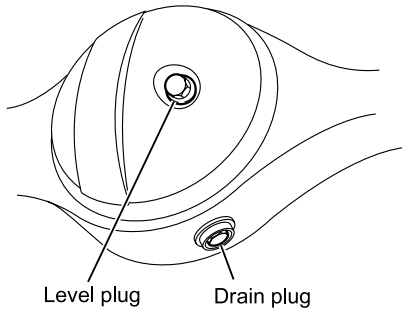

1. Place a container under the drain plug to receive oil.
2. Remove the plugs indicated in the figure to discharge the oil into the container.
3. After installing the drain plug by tightening it to the specified torque, refill the rear axle differential with new oil through the oil level plug hole up to the lower edge of the hole.

Plug tightening torque

84 N·m (8.6 kgf·m/62 lb·ft)



ADVICE

- Any dirt on the plug should be wiped off before installing it.

4. After refilling, confirm that the oil level is up to the lower edge of the oil level plug hole.
5. Install the oil level plug by tightening it to the specified torque.

Plug tightening torque

84 N·m (8.6 kgf·m/62 lb·ft)

Quantity of rear axle differential gear oil to be changed

Specifications	Oil quantity [Reference value]
292 mm final drive	3.0 litres (0.79 US gal./0.66 Imp gal.)
320 mm final drive (all except straight frame models)	3.4 litres (0.89 US gal./0.75 Imp gal.)
320 mm final drive (straight frame model)	4.3 litres (1.14 US gal./0.95 Imp gal.)

**ADVICE**

- Use only the Isuzu recommended differential gear oil.

Recommended Fluids, Lubricants and Diesel Fuels → Refer to page 7-172

Front Axle Differential Gear Oil V

The front axle differential gear oil level must be checked and it must be changed according to the Maintenance Schedule.

Maintenance Schedule

→ Refer to page 7-159

Checking the Oil Level

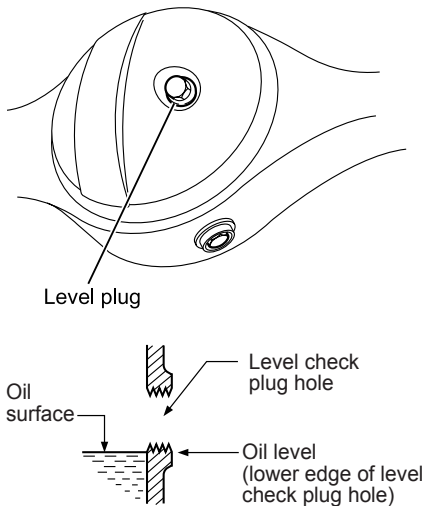

1. Remove the oil level plug.

2. Check that the oil level is up to the lower edge of the oil level plug hole.
 - If the oil level is too low, add oil through the oil level plug hole.
3. Fasten the oil level plug to the specified torque.

Plug tightening torque

84 N·m (8.6 kgf·m/62 lb·ft)

**ADVICE**

- Any dirt on the plug should be wiped off before installing it.

Changing the Oil

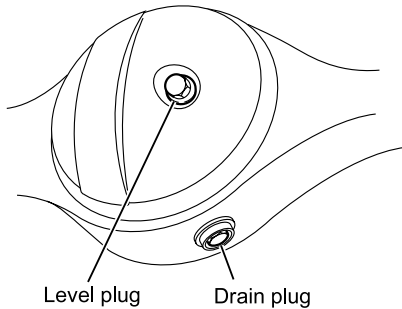

1. Place a container under the drain plug to receive oil.

**ADVICE**

- Use the oil quantities indicated below only as guidelines when changing the front axle differential oil. After changing the oil, ensure that its level is as required.
- Drained oil must be disposed of in a method conforming to the regulatory requirements in your country.

2. Remove the plugs indicated in the figure to discharge the oil into the container.
3. After installing the drain plug by tightening it to the specified torque, refill the front axle differential with new oil through the oil level plug hole up to the lower edge of the hole.

Plug tightening torque

84 N·m (8.6 kgf·m/62 lb·ft)

**ADVICE**

- Any dirt on the plug should be wiped off before installing it.
4. After refilling, confirm that the oil level is up to the lower edge of the oil level plug hole.
 5. Install the oil level plug by tightening it to the specified torque.

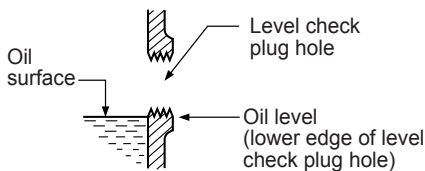

Plug tightening torque

84 N·m (8.6 kgf·m/62 lb·ft)

**ADVICE**

- Any dirt on the plug should be wiped off before installing it.

Quantity of front axle differential gear oil to be changed

Oil quantity [Reference value]

2.7 litres (0.71 US gal./0.59 Imp gal.)

Transfer Gear Case Oil v

The transfer gear case oil level must be checked and it must be changed according to the Maintenance Schedule.

Maintenance Schedule

→ Refer to page 7-159

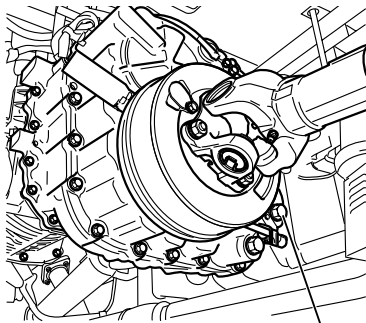
Checking the Oil Level

Level plug

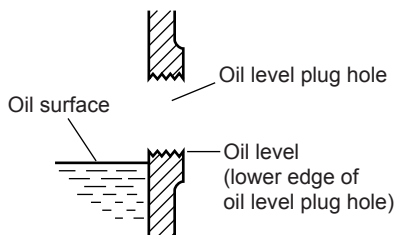

1. Remove the oil level plug.

2. Check that the oil level is up to the lower edge of the oil level plug hole.

- If the oil level is too low, add oil through the oil level plug hole.

3. Fasten the oil level plug to the specified torque.

Plug tightening torque

39 N·m (4.0 kgf·m/29 lb·ft)

**ADVICE**

- Any dirt on the plug should be wiped off before installing it.

Changing the Oil

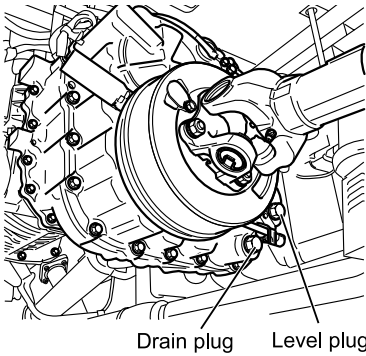

1. Place a container under the drain plug to receive oil.
2. Remove both the oil level plug and the drain plug to discharge the oil into the container.



ADVICE

- Use the oil quantity indicated below only as a guideline when changing the transfer gear case oil. After changing the oil, ensure that its level is as required.
- Drained oil must be disposed of in a method conforming to the regulatory requirements in your country.

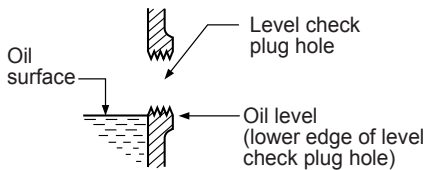

3. After installing the drain plug by tightening it to the specified torque, refill the transfer gear case with new oil through the oil level plug hole and up to the lower edge of the hole.

Drain plug tightening torque

39 N·m (4.0 kgf·m/29 lb·ft)



ADVICE

- Any dirt on the plug should be wiped off before installing it.
4. After refilling, confirm that the oil level is up to the lower edge of the oil level plug hole.
 5. Install the oil level plug by tightening it to the specified torque.

Oil level plug tightening torque

39 N·m (4.0 kgf·m/29 lb·ft)

**ADVICE**

- Any dirt on the plug should be wiped off before installing it.

Quantity of transfer gear case oil to be changed

Oil quantity [Reference value]

1.8 litres (0.48 US gal./0.40 Imp gal.)

Power Steering Fluid

The power steering fluid level must be checked and it must be changed according to the Maintenance Schedule.

Maintenance Schedule

→ Refer to page 7-159

Checking the Power Steering Fluid Level

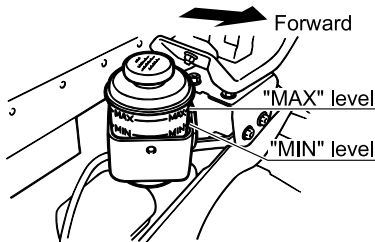

The fluid level is correct if it is between the "MAX" and "MIN" lines on the reserve tank. If the level is lower than the "MIN" line, add fluid up to the "MAX" line.

The reserve tank is located at the rear of the engine compartment on the right. When you have finished checking the fluid level, securely install the cap and cover.

Rear Inspection Hatches (Crew Cab

Model)

→ Refer to page 7-11



CAUTION

- Before adding fluid, clean the area around the cap and pour fluid from a clean jug or filler. Foreign matter getting in the tank will cause power steering system failure.
- Do not mix the recommended power steering fluid with fluids of other brands. Due to chemical reactions, any mixture of differently branded fluids will cause failure of the system.

Changing the Power Steering Fluid

Rack and pinion

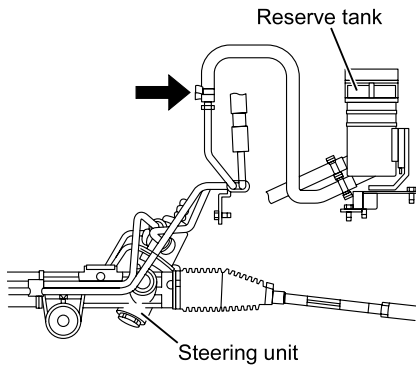

Recirculating balls

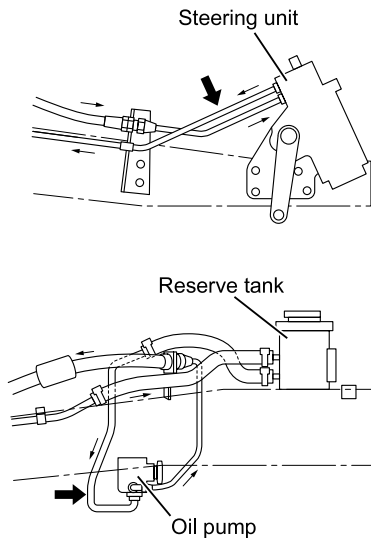

Draining

1. Apply the parking brake firmly and chock the rear wheels.
2. Firmly apply the head of the jack to the jacking point.
3. Raise the vehicle until the front wheels are completely clear of the ground.
4. Disconnect the oil pipe between the steering unit and reserve tank as well as the oil hose between the oil pump and reserve tank, and discharge the power steering fluid.
5. When the power steering fluid has been completely discharged, turn the steering wheel fully to the left and right several times to remove fluid left in the piping.

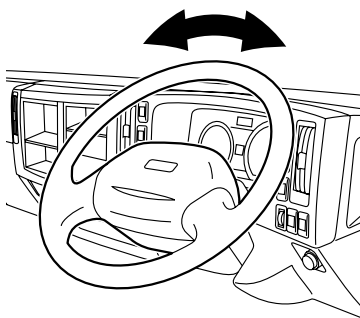
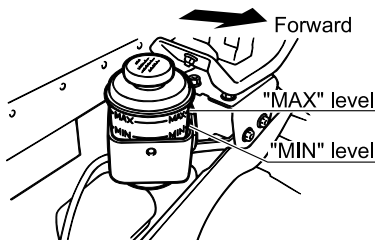

Refilling

1. Securely connect the oil pipe and oil hose, and then refill the reserve tank with the specified power steering fluid.
2. When the reservoir tank is filled with the fluid up to the specified level, wait for 2 to 3 minutes to allow the fluid level to lower.
3. Without running the engine, fully turn the steering wheel in both directions a few times.
4. Lower the vehicle and start the engine. While running the engine at idle, fully turn the steering wheel in both directions a few times. If you do not hear any abnormal sounds, the system has been properly bled.



CAUTION

- While refilling the system, keep the reserve tank full of the fluid by making additions as necessary to prevent air from getting into the hydraulic system.

Bleeding

If you hear any abnormal sounds when you turn the steering wheel, air has gotten trapped in the hydraulic system. Follow the steps below to bleed the system.

1. Apply the parking brake firmly and chock the rear wheels.
2. Apply the head of the jack to the jacking point firmly.
3. Raise the vehicle until the front wheels are completely clear of the ground.

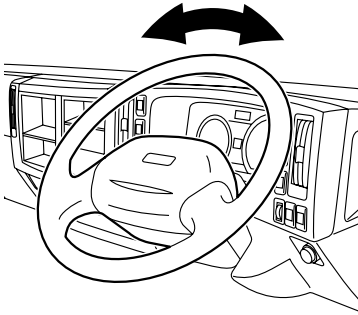

4. Start the engine. Turn the steering wheel fully in both directions a few times.
5. Lower the vehicle. With the engine still running, fully turn the steering wheel in both directions a few times. If you do not hear any abnormal sounds, the system has been properly bled. If you still hear any abnormal sounds, this means there is air remaining in the power steering system. To remove the remaining air from the system, fully turn the steering wheel in both directions a few times to increase the fluid temperature. When the fluid temperature has risen to between 60 to 80°C (140 to 176°F), stop the engine and wait for about 5 minutes (allowing air to be collected from high temperature fluid).
6. Check the level of the fluid in the reservoir and also check the joints for fluid leaks.
7. Test drive the vehicle on a road while checking that the steering wheel turns smoothly and the system produces no abnormal sounds when you turn the steering wheel.

Hub Bearing Grease

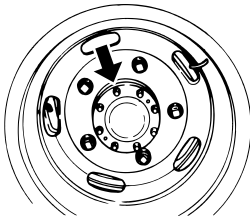

As disassembly and reassembly will be required in order to replace front and rear bearing grease, have these operations performed by your Isuzu Dealer.

Greasing Chassis Components



The type (characteristics) of the grease specified for use with a chassis component differs from that of the grease specified for use with another component. Be sure to use only the specified grease for each component and perform greasing according to the Maintenance Schedule.

Maintenance Schedule

→ Refer to page 7-159

Recommended Fluids, Lubricants and

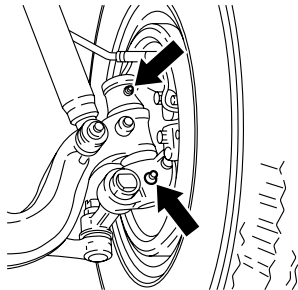
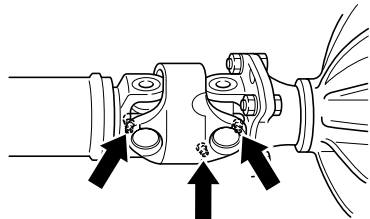
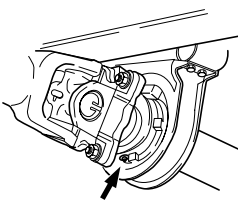
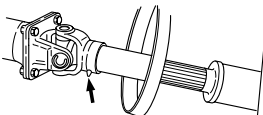
Diesel Fuels → Refer to page 7-172

<p>King pins (left and right)</p>  <p>2 points each Rigid axle suspension</p>	<p>Front propeller shaft Double cardan joint</p>  <p>3 points 4WD model</p>
<p>Propeller shaft centre bearing</p> 	<p>Propeller shaft splines</p> 
<p>Propeller shaft universal joint</p>  <p>Single-piece propeller shaft: 2 points; Two-piece propeller shaft: 3 points</p>	

**ADVICE**

- Each of propeller shaft universal joint must be greased heavily until grease oozes at the 4 needle bearing oil seal locations. After greasing, wipe off excess grease.



OTHER SERVICE AND MAINTENANCE

• Handling the Jack	7-128
• Windshield Washer Fluid	7-133
• Windshield Wiper Blades	7-134
• Headlights and Turn Signal Lights	7-137
• Handling the Battery	7-138
• Air Conditioning Filters <input type="checkbox"/>	7-144
• Refrigerant <input type="checkbox"/>	7-146

Handling the Jack

WARNING

- Raising the vehicle with a jack could lead to an accident when carried out on soft or inclined surfaces. Ensure that you always carry out this operation on flat, solid surfaces.
- Always apply the parking brake fully and correctly chock the wheels before jacking the vehicle. Applying only the parking brake is insufficient to prevent the vehicle from moving; when a rear wheel is jacked up, the vehicle blocked only by the parking brake could move, creating a very dangerous situation.
- Ensure that there are no people or objects present in the vehicle before it is jacked up.
- In order to ensure safety, doors should never be opened and the engine should never be started during a jack-up operation. In addition, you should never have any part of your body below the vehicle at this time, nor allow anybody else to do so. Failure to observe this precaution could lead to an accident if the jack were to slip.
- If the underside of the vehicle is to be worked on after jacking up, jack stands must be used to support the vehicle.
- The jack must only be used at one of the specified jacking points. In addition, you must confirm that it makes good contact with the specified point.
- In order to provide extra safety should the jack slip, once a spare tyre has been removed, it should be placed under the vehicle near the jack.
- Before starting a jacking operation, ensure that the jack and the jacking point to be used are clear of dirt, oil and grease. Failure to observe this precaution could lead to an accident should the dirt or oil cause the jack to slip.
- If your vehicle is equipped with a differential lock system or limited slip differential (LSD), it might start moving when the engine power is transmitted to the rear axle even when one of the wheels on the axle is raised clear of the ground. Do not start the engine with any rear wheel in contact with the ground.
- The jack provided with your vehicle must be used only for changing tyres and fitting or removing tyre chains. In order to ensure safety, furthermore, only one wheel should be jacked up at a time.
- If using a two-stage, extension type jack and the stop mark (yellow) becomes visible, stop raising the vehicle. Failure to observe this precaution can result in jack breakage.
- Do not use more than one jack at any one time.
- The jack supplied with your vehicle is specifically for that vehicle. Do not use it on another vehicle and never use another vehicle's jack.
- Turn the bleeder screw slowly. Turning it quickly will cause the vehicle to drop and the jack may slip off.

Operating the Jack



Raising the Vehicle

1. Place the jack immediately below the jacking point and ensure that it is upright.

The jack must be placed on a flat, solid surface.

Front Wheel Jacking Points

→ Refer to page 7-130

Rear Wheel Jacking Points

→ Refer to page 7-131

Jacking When a Front Tyre Is Flat

→ Refer to page 7-132

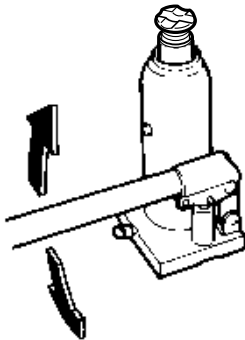
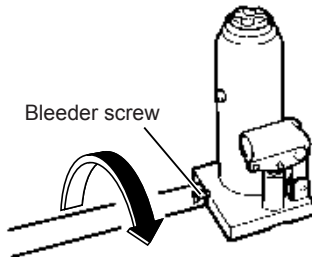

2. Turn the head of the jack to extend it to the height of the jacking point. Turn it counterclockwise to extend.
3. Insert the jack handle into the socket. Before jacking up, use the notched end of the jack handle to turn the bleeder screw fully clockwise.
4. Move the jack handle gently up and down to extend it slightly.
5. Confirm that the jack is in good contact with the jacking point, and then continue to raise the vehicle.

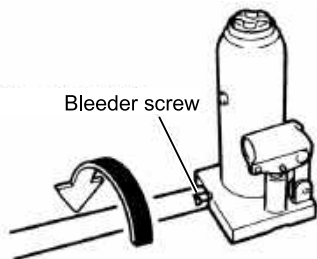

Lowering the Vehicle

1. Line up the jack handle end notch with the bleeder screw.
2. Slowly turn the bleeder screw counterclockwise to lower the vehicle.
3. When the vehicle has been fully lowered, turn the bleeder screw as far as it will go in the clockwise direction.
4. Turn the jack head fully clockwise.

Front Wheel Jacking Points

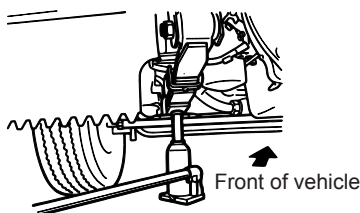

All Except Model with Independent Front Suspension

Apply the jack to the leaf spring.

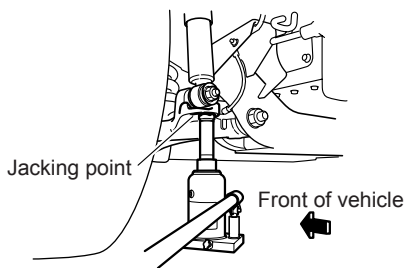

Model with Independent Front Suspension

Apply the jack to the jacking point behind the lower link.

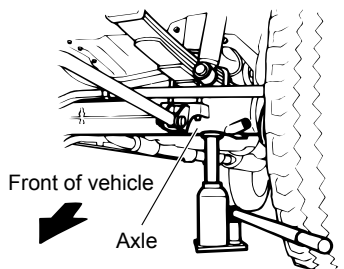

Four Wheel Drive (4WD) Model

Apply the jack to the bottom of the axle.

Rear Wheel Jacking Points

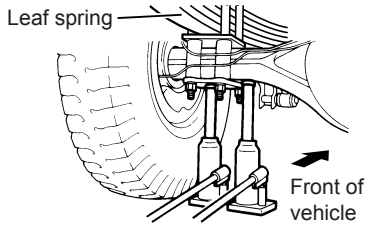

Over-slung Leaf Spring Suspension Model

(single tyre model, dual tyre model, flat-low model)

Apply the jack to the bottom of the leaf spring or axle case.

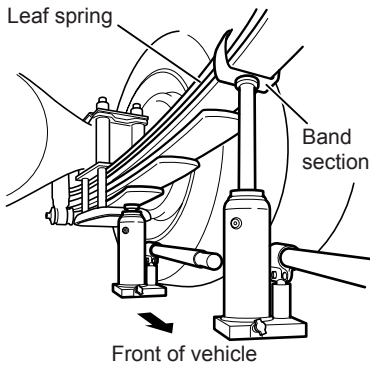

Under-slung Leaf Spring Suspension Model

(some dual tyre models, standard full-flat low model)

Apply the jack to the bottom of the leaf spring or to the band-section rivet at the front of the vehicle.

Jacking When a Front Tyre Is Flat

WARNING

- Position the jack as close as possible to the front axle.
- The wood block should be as thick as possible in order to improve stability.
- As the bottom of the leaf spring is curved, special care must be taken during the jacking operation. Slipping of the jack can lead to extremely dangerous situations such as entrapment beneath the vehicle.

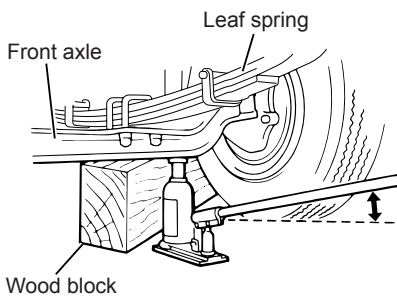
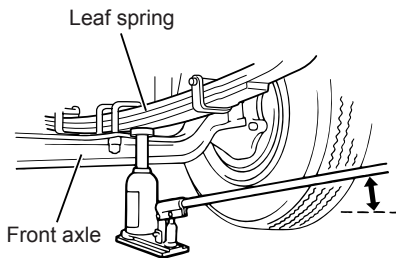

Jacking cannot be performed using the normal jacking points in the case of a flat front tyre. You must use the following procedures using a wood block or the equivalent.

1. Apply wheel chocks in front of and behind the rear wheels.
2. Apply the jack to the bottom of the leaf spring in front of the front axle, and jack up the vehicle.
3. Insert the wood block under the front axle.
4. Lower the jack slightly to confirm whether the front axle is being supported securely by the wood block. If so, continue lowering the jack.
5. Next, move the jack to the specified jacking point and jack up the vehicle to the necessary height for wheel removal.

Front Wheel Jacking Points

→ Refer to page 7-130

Windshield Washer Fluid

Windshield Wiper/Washer

Check the level of fluid in the windshield washer tank. In addition, spray windshield washer fluid and operate the windshield wipers to check for any areas not properly wiped. At this time, also check the windshield washer's spraying condition.

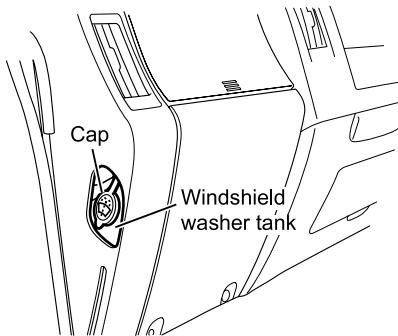

Refilling Windshield Washer Fluid

1. The windshield washer fluid tank is located under the instrument panel on the passenger side.
2. Open the cap and fill the tank with windshield washer fluid to the opening.



ADVICE

- Upon factory shipment, new vehicles contain only tap water in the washer fluid tank. Adjust the concentration of the fluid to suit your own usage.
- Follow the instructions provided with the windshield washer fluid regarding the ratio for mixing with tap water.
- Poor quality products, engine coolant, and soapy water must not be used. Failure to observe this precaution can result in nozzle blockage or damage to painted surfaces.
- The washer should never be used while the tank is empty. Operating the washer with the tank empty can result in motor damage.

Windshield Wiper Blades

Daily Checks

Spray windshield washer fluid and then operate the windshield wipers to check for any poorly wiped areas. In addition, confirm that each of the "☒" (intermittent), "LO", and "HI" functions operate normally.

Windshield Wiper Blade Replacement

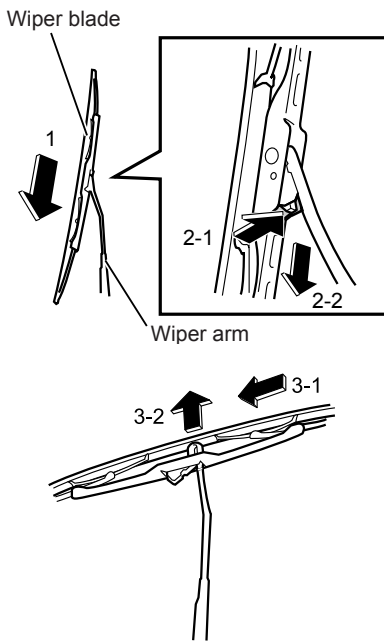

Removal

1. Pull the wiper arm up to the vertical position.
2. While pressing the wiper-blade hook towards the arm, slide the blade downwards (towards the base of the arm).
3. With the blade and arm almost perpendicular, remove the blade from the arm.

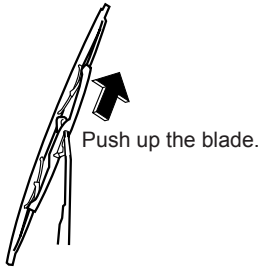
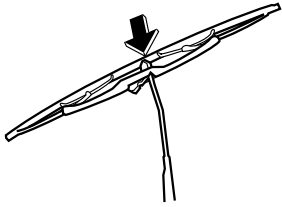

Installation

1. Insert the blade while holding it almost perpendicular to the arm.
2. Then, with the blade and arm oriented in the same direction, push up the blade until it locks into place on the arm.



ADVICE

- Do not lower the wiper arm with its blade removed; the windshield glass may be scratched.
- Whenever a wiper blade has been attached, ensure that it is locked into place. Failure to observe this precaution can result in the wiper blade becoming dislocated when the windshield wiper switch is turned on.

Replacement of Wiper Rubber Insert

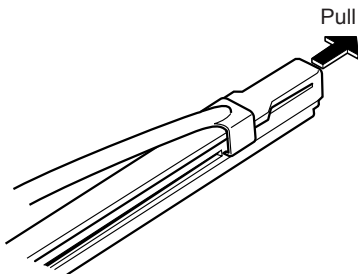

Removal

1. Remove the wiper blade from the wiper arm.
2. Pull the wiper rubber insert in the direction indicated by the arrow and extract it from the wiper blade.

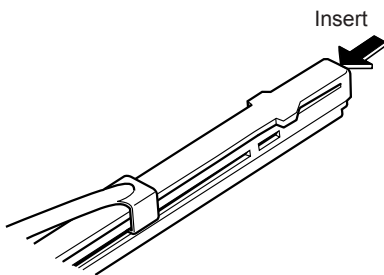

Installation

1. Insert a new wiper rubber insert into the wiper blade.

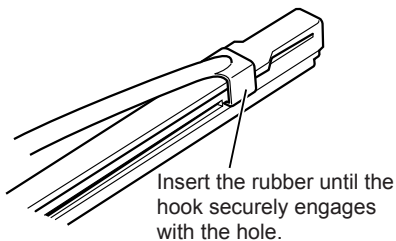

2. Continue pushing in the wiper rubber insert until the wiper blade's hook engages with the hole in it, and then confirm that the rubber insert is securely held in place.
3. Attach the wiper blade to the wiper arm.

Headlights and Turn Signal Lights

Turn the starter switch to the "ON" position, and then check the way in which the headlights, turn signal lights, and other exterior lights come on and flash.

In addition, depress the brake pedal to confirm whether the stop lights come on, and shift the transmission to "R" position to confirm whether the back up lights come on.

Also examine the lights for discoloration, damage, and looseness.

When the Bulb Does not Come On

→ Refer to page 8-24

Front

NLR/NNR/NPR/NQR/NPS models

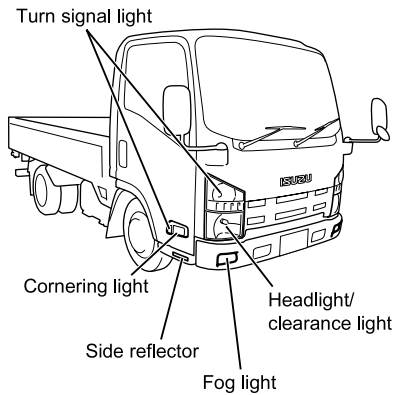

Rear

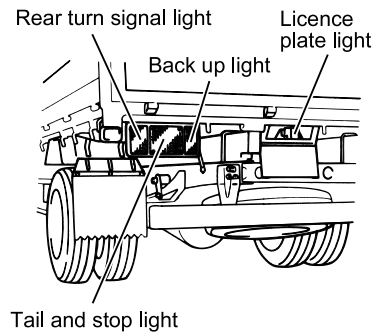

Handling the Battery



DANGER

- Usage or charging of the battery when the battery fluid is below the "LOWER LEVEL" line can accelerate deterioration and give rise to dangerous situations such as the generation of heat and even explosion.
- If battery fluid should come in contact with an eye, immediately wash away using a large amount of water and continue washing for at least five minutes. Following this, you should seek medical assistance.
- When using tools or other metal objects in the vicinity of the battery, take care to prevent them from coming into contact with the positive terminal. As the vehicle itself will conduct electricity, any such contact can result in a short-circuit and a highly dangerous electric shock.
- A vehicle battery generates extremely flammable hydrogen gas. For this reason, operations producing sparks or requiring the usage of an open flame must never be carried out near a vehicle battery. Failure to observe this precaution can result in explosion if the hydrogen gas ignites. Whenever wiping up battery fluid, a damp cloth should be used.



WARNING

- Always stop the engine whenever the battery is to be inspected.
- Dilute sulfuric acid is used as the battery fluid. Special care must be taken to ensure that this fluid does not come into contact with skin, clothing, or metal surfaces.
- When disconnecting the cables from the terminals, start with the negative terminal. When connecting them, the negative terminal should be reconnected last.



ADVICE

- Battery fluid should never be filled beyond the "UPPER LEVEL" line. Failure to observe this precaution can result in battery fluid spillage and corrosion of battery terminals and other components. Any spilled battery fluid should be immediately washed away with water.
- Whenever battery fluid has been added, the battery should be recharged (by driving the vehicle). In winter months in particular, battery fluid can freeze and damage the battery case if you fail to recharge the battery.
- If the battery fluid level continues to drop at an unusually fast rate, have an inspection carried out immediately by the nearest Isuzu Dealer.

Battery Handling Precautions

Keep the battery clean. If the battery is left in a dirty condition, contaminants can get mixed into the battery fluid, the battery plates can be damaged, short circuits can occur on the top surface of the battery and the battery's service life can be reduced.

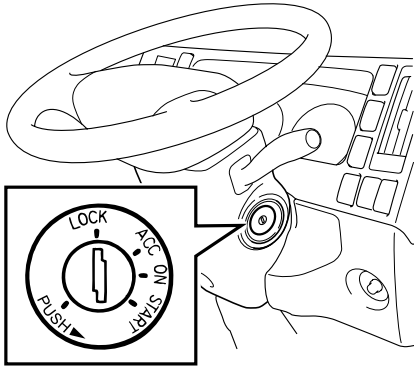

When Performing Inspection or Maintenance

Before starting inspection and maintenance of the battery and other parts of the electrical system, set the starter switch to the "LOCK" position, turn all other switches "OFF" and disconnect the battery's negative cables from the terminals.

There is a danger that electrical components could be damaged if inspection or maintenance is carried out if the battery remains connected.

Removing the Battery

When the battery is to be removed, disconnect the battery cable from the negative terminal first. If the battery cable remains connected to the negative terminal, any contact made by tools and the like between the positive terminal and the vehicle body could lead to a short-circuit and dangerous electrical shocks. The electrical system can also be damaged.

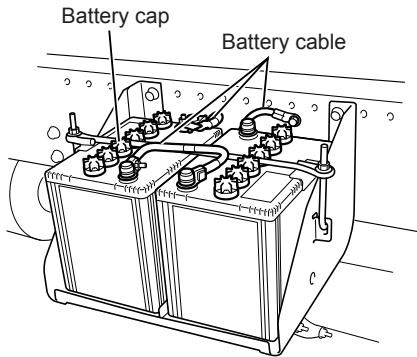

Charging the Battery

1. Before charging the battery, remove it from the vehicle to a location with good ventilation and take off the battery caps. If, on the other hand, the battery is to be charged while still on the vehicle, be sure to first disconnect the battery cables.
2. Whenever a charger is being connected to or disconnected from a battery, ensure that it is turned off.
3. Battery cables must always be disconnected when performing quick charging.
Failure to observe this precaution can result in alternator burnout.

DANGER

- Do not use open flames in the vicinity of the battery when it is being charged. Hydrogen gas is generated by the battery during the charging process; accordingly, failure to observe this precaution can result in fire or explosion.

Installing the Battery

1. When installing the battery in your vehicle, ensure that it is oriented correctly and securely fastened without any looseness. If the battery is not installed correctly, the battery case and battery plates can be damaged as a result of vibrations during driving.
2. When connecting the battery cables, start with the positive terminal and then connect the negative terminal.

CAUTION

- Take care to avoid mixing up the positive and negative terminals when connecting battery cables. Incorrect connection to these terminals can result in flow of excessive current and burnout of the alternator or vehicle wiring.

Using the Battery as a Direct Power Source

The battery should not be used as a direct source of 12-volt power.

If your battery must be used as a direct power source, please consult with your Isuzu Dealer.

Checking the Battery Fluid Level

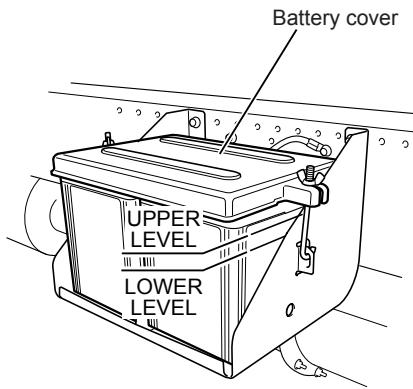

Single Cab Model

The battery is located almost exactly at the centre of the outside chassis member.

Daily Check

Remove the battery cover and confirm whether the level of fluid inside the battery case is within the specified range.

The surface of the battery fluid should be between the "UPPER LEVEL" and "LOWER LEVEL" lines. If the surface of the fluid cannot easily be seen, rock the vehicle gently.

If no level marks are indicated on the case, a range between 10 and 15 mm (0.39 to 0.59 inches) from the top of the battery plates is considered appropriate.

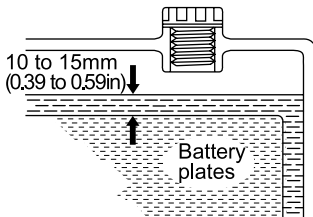

Filling Battery Fluid

If the quantity of battery fluid inside the battery is insufficient, remove the cover and cap, and then add distilled water until the surface is close to the "UPPER LEVEL" mark or in a range between 10 and 15 mm (0.39 to 0.59 inches) from the top of the battery plates. When you have finished adding the distilled water, securely install the cap and battery cover.



ADVICE

- Battery fluid should never be filled beyond the "UPPER LEVEL" line. Failure to observe this precaution can result in battery fluid spillage and corrosion of battery terminals and other components. Any spilled battery fluid should be immediately washed away with water.
- Whenever battery fluid has been added, the battery should be recharged (by driving the vehicle). In winter months in particular, battery fluid can freeze and damage the battery case if you fail to recharge the battery.
- If the battery fluid level continues to drop at an unusually fast rate, have an inspection carried out immediately by the nearest Isuzu Dealer.

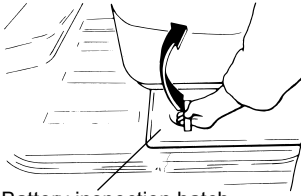

Battery inspection hatch

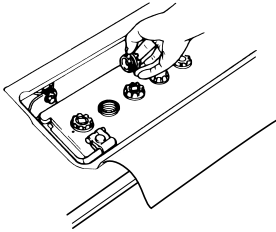
**Crew Cab Model**

Open the battery inspection hatch located under the left side of the rear seat to check the battery fluid level.

Daily Check

Remove the cap and look inside. The level of fluid is sufficient if the surface is just below the opening.

Filling Battery Fluid

If the battery fluid level is too low, add distilled water until the surface is between 10 and 15 mm from the top of the battery plates.

**ADVICE**

- Battery fluid should never be filled beyond the "UPPER LEVEL" line. Failure to observe this precaution can result in battery fluid spillage and corrosion of battery terminals and other components. Any spilled battery fluid should be immediately washed away with water.
- Whenever battery fluid has been added, the battery should be recharged (by driving the vehicle). In winter months in particular, battery fluid can freeze and damage the battery case if you fail to recharge the battery.
- If the battery fluid level continues to drop at an unusually fast rate, have an inspection carried out immediately by the nearest Isuzu Dealer.

Checking the Specific Gravity of Battery Fluid

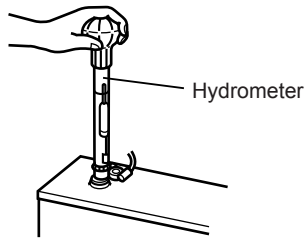

1. Check the specific gravity of the battery fluid using a hydrometer. If the specific gravity is too low, the battery should be charged.

Specific gravity at a fluid temperature of
20°C (68°F)

1.27 - 1.29

Checking the Battery Terminals



1. Check the terminals for looseness and corrosion.
2. If a terminal is found to be corroded and coated in white powder, wash this away with warm water and then wipe fully dry. Excessively corroded terminals should be polished using a wire brush or sandpaper.
3. When you have finished cleaning the terminals, apply a thin layer of grease and securely connect the battery cables, taking care to ensure that they are tight.
See "If the Battery Runs Flat" regarding steps to be taken should the battery be completely discharged.

Tightening torque for terminal nuts

5 - 7 N·m (0.5 - 0.7 kgf·m/43 - 61 lb·in)

When the Battery Goes Flat

→ Refer to page 8-12

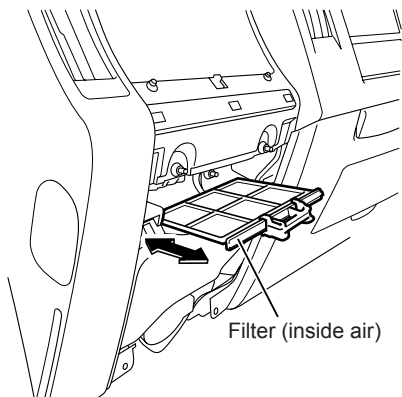
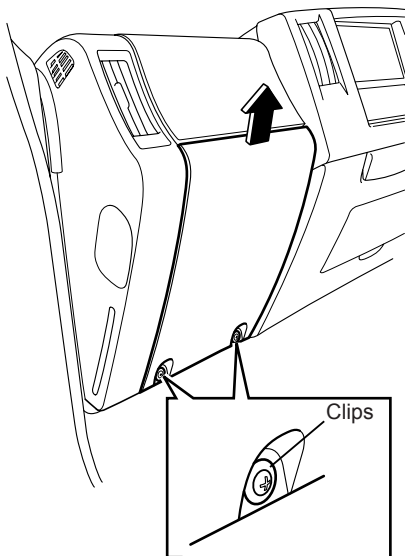
Air Conditioning Filters v**Removing the Inside Air Filter
(All Models)**

1. Loosen the screws at the centre of the 2 clips securing the cover and pull out the clips.
2. Remove the cover by pushing it upwards.

3. Remove the filter. Use a vacuum cleaner or the like to clean dust and dirt from its surface.

**ADVICE**

- Avoid interference with electric harnesses when removing the filter.
- In order to avoid filter damage, hard brushes should not be used for filter cleaning.

Installing the Inside Air Filter (All Models)

1. Install the filter in the reverse order to removal.

CAUTION

- Ensure that the filter is returned securely to its original position. Failure to observe this precaution can lead to rattling during travel, or should the filter become loose, to very dangerous situations.
- The vehicle must not be used with the filter removed or incorrectly installed. Failure to observe this precaution can lead to air conditioning system damage as a result of dust, dirt and the like entering the system.

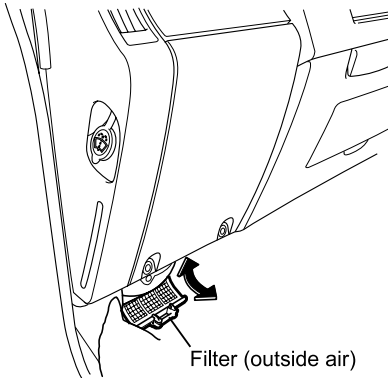
**Removing the Outside Air Filter (NLR/NNR/NPR/NQR/NPS Models)**

1. Remove the filter from under the instrument panel on the passenger side. While pressing in the filter lock, on both sides, pull out the filter.
2. Use a vacuum cleaner or the like to clean dust and dirt from its surface.

ADVICE

- In order to avoid filter damage, hard brushes should not be used for filter cleaning.

Installing the Outside Air Filter (NLR/NNR/NPR/NQR/NPS Models)

1. Install the filter in the reverse order to removal.

ADVICE

- Ensure that the filter is returned securely to its original position. Failure to observe this precaution can lead to rattling during travel, or should the filter become loose, to very dangerous situations.
- The vehicle must not be used with the filter removed or incorrectly installed. Failure to observe this precaution can lead to air conditioning system damage as a result of dust, dirt, water, snow, and the like entering the system.

Refrigerant V

The air conditioning system will not be able to cool the cab interior effectively if the refrigerant level is low. Accordingly, the refrigerant level must be topped up whenever necessary.

Please contact your Isuzu Dealer whenever refrigerant must be added.

**ADVICE**

- Operating the air conditioning while the refrigerant level is too low leads not only to poor cooling performance but also to air conditioning system damage.
- This vehicle uses the new refrigerant HFC134a (R134a) in the air conditioning system. No other type of refrigerant can be used. In order to protect the environment, care must be taken to ensure that refrigerant gas is never released into open air. When refrigerant must be replaced, therefore, please contact your Isuzu Dealer or other service facility equipped with a gas recovery installation system.

INTERIOR AND EXTERIOR MAINTENANCE

• Exterior Maintenance	7-148
• Interior Maintenance	7-151

Exterior Maintenance

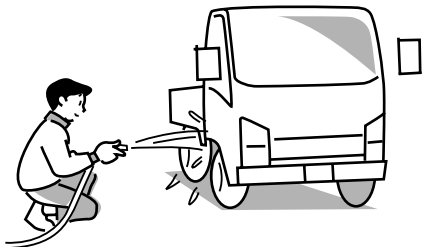

Washing

If the vehicle is operated with foreign material adhering to the exterior, this material may react chemically with paint, resulting in staining, discoloration, rusting or corrosion of components. Also, the material may become trapped within mechanical components, adversely affecting their functions or forming an aerodynamic resistance. In the following cases, therefore, the vehicle must be washed and all foreign matter removed.

- When soot, iron powder, dead bugs, bird droppings, tree sap or oily matter from coal tar and smoke has adhered to painted surfaces.
 - When the vehicle has been driven in coastal areas.
 - When the vehicle has been driven on roads where road chemicals have been applied.
 - When a large amount of mud or dirt has adhered to the exterior.
1. Fully turn on the tap, and wash out the undercarriage and suspension.
 2. Close all openings and wash the cab and cargo body panels using a neutral detergent.
 3. Clean wheels and tyres using a brush and detergent.
 4. After washing away all remaining detergent, use a shammy or other clean cloth to fully remove all moisture and water droplets.



CAUTION

- Do not apply water directly in order to clean the cab interior. Failure to observe this precaution can result in malfunction or breakdown of electronic control units and electrical components, or in rusting of the cab floor.
- Do not apply water from a high-pressure washer nozzle directly to the electric connectors. Failure to observe this precaution can lead to faulty operation of the electrical system.

**ADVICE**

- If an automatic car or truck-wash is used with vehicles having dark or metallic coating, the painted surfaces can be damaged by the brushes, lose their luster or be very noticeably scratched.
- Do not direct a large amount of water at the air inlet openings.
- Do not apply water to the engine compartment or at electrical components. Failure to observe this precaution can lead to a poorly starting and operating engine and problems in the electrical system.
- Ensure that mirrors and the antenna are retracted before washing the vehicle.
- If an automatic car or truck-wash must be used, avoid a high-temperature, high-pressure type machine. Failure to observe this precaution can lead to heat deformation and breakage of plastic components, or to water leaks into the cab.
- When using an automatic car or truck-wash, ensure that a distance of at least 0.4 m (15.75 inches) is maintained between the nozzle and the vehicle, and when washing door windows, that the spray is perpendicular to the surface of the glass.
- Ensure that all detergent is fully washed and wiped away. Particularly in the case of strong alkaline detergents (typically those for industrial uses), there is a danger that hairline cracks can develop in lighting-cluster lenses if the vehicle is operated without detergent being fully wiped away. Always read the detergent manufacturer's instructions carefully before use.
- Airborne dirt that adheres to plastic front bumpers as a result of rain, for example, can be difficult to remove.
In such a case, use a commercially-available cleaner to clean away the dirt, and then apply a wax for use with plastic components.

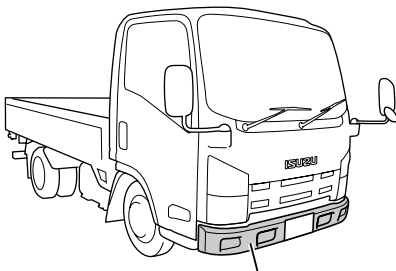

Front bumper

Vehicle Storage

In order to maintain your vehicle's attractive appearance as long as possible, special consideration must be given to its storage location.

If the vehicle is stored or kept for an extended period of time in any of the following locations, a chemical change may occur in the paintwork, resulting in staining, discoloration, rusting, and corrosion of components.

- Locations where a large amount of oily matter, soot, heavy smoke or metal powder can adhere to the vehicle.
- Areas around pharmaceutical plants and other facilities that discharge chemical matter.
- Coastal areas
- Locations where a large amount of dead bugs, bird droppings or tree sap can adhere to the vehicle.

Waxing

Painted and chrome-plated surfaces should be waxed once or twice a month, or whenever water is being poorly repelled on the surfaces. Ensure that wax is not applied in direct sunlight, and that the temperature of the painted surface is no more than 40°C (104°F).

Always follow the instructions provided with your wax product.



CAUTION

- Wax must not be applied to the windshield. Failure to observe this precaution can result in irregular reflection of light, impairing your view.



ADVICE

- Do not use wax containing abrasive material. Failure to observe this precaution can lead to scratching of painted surfaces or plastic components.
- The application of wax to rubber component surfaces can result in permanent whitening.



NOTE

- Wax must not be applied to the windshield. A layer of wax can impair your view in rainy weather and can also lead to rough movements of the windshield wiper.
- If engine oil or grease comes into contact with the windshield, staining or discoloration may result. It must be immediately cleaned away.



Windshield Care

If not fully cleaned by the windshield wipers, the windshield should be cleaned using Isuzu genuine glass cleaner.

Interior Maintenance

Remove dust and dirt from the interior of the cab using an automotive cleaner or vacuum cleaner, and gently wipe surfaces clean using a cloth wet with warm or cold water.

WARNING

- When cleaning the interior of the cab, water should never be sprayed directly. Failure to observe this precaution can lead to vehicle malfunction and possibly to fire if water should enter the audio system or other electrical components located underneath the floor carpet.
- Petroleum ether, gasoline and other organic solvents should not be used to clean seat belts.
In addition, seat belt webbing should be neither bleached nor redyed. Failure to observe these precautions can lead to the performance or strength of the seat belts being impaired. In the case of a collision, therefore, the belts could be insufficiently effective, and serious life-threatening injuries could result. When cleaning, use warm water in which a small amount of neutral detergent has been dissolved to gently wipe the seat belts.

CAUTION

- The interior of the vehicle must never be cleaned using acidic or alkaline solvents, or petroleum ether, gasoline, and other organic solvents. Failure to observe this precaution can result in discoloration and staining. It should be noted that certain types of cleaning products contain these compounds. Be sure to read cleaning product labels carefully.
- Air fresheners (liquid, solid, gel or plate types) must not come into direct contact with, or spill onto, interior components such as the air conditioning or audio system. Compounds contained in these products can cause discoloration, staining or peeling of paint.
- Glass cleaners that contain these compounds must not be used to clean the inside of the windshield or window glass. To clean the glass, wipe using a cloth wet with warm or cold water.

Seat Belt Care

A dirty seat belt can develop retracting problems, and for this reason, regular inspection and upkeep are required.



CAUTION

- Seat belt webbing can lose its strength when bleached or redyed, or when cleaned using gasoline, paint thinners or other volatile substances.
- Do not disassemble the seat belt mechanism in order to remove any foreign material or objects that may have entered the buckle. Instead, arrange for inspection and maintenance to be carried out by your Isuzu Dealer.

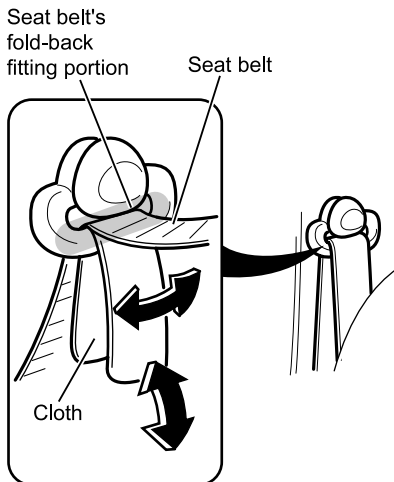

Cleaning a Seat Belt's Fold-back Fitting Portion

1. Fold a piece of cotton cloth, absorbent gauze, or the like of approximately 50 mm (2 in) in width into a rectangle.
2. Mix one part neutral detergent into approximately twenty parts warm water.
3. Wet the cloth in the detergent mixture, pass it through the fold-back fitting portion of the belt, and slide it back and forth and laterally until dirt can no longer be seen.
4. Remove the cloth, remove moisture from the fitting portion of the belt using a dry cloth, and then allow it to dry naturally out of direct sunlight.
5. Check to be sure the seat belt retracts and pulls out correctly.



ADVICE

- Avoid using anything like a tool to pass the cloth through the fold-back fitting portion or try to remove stubborn dirt. Using such an object can result in plastic parts or seat belt webbing damage.

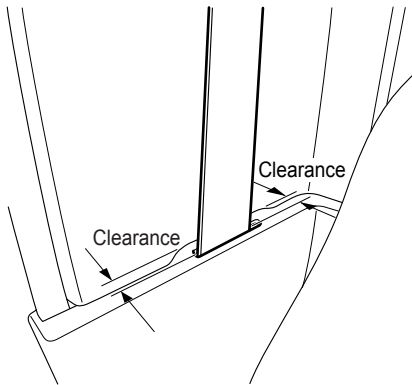
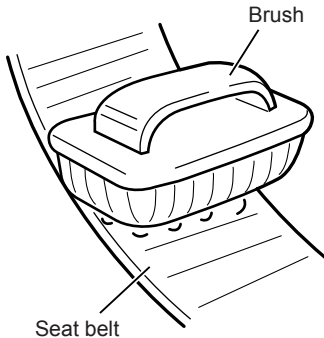

Cleaning a Belt Webbing

1. Fully extract the belt and examine for any difference in color between the front and back surfaces.
2. Mix one part neutral detergent into approximately twenty parts warm water.
3. Wet a nail brush or another similar brush having soft bristles (of nylon or the like) in warm water, and use this to clean away dirt.
4. Wipe the seat belt dry using a dry cloth, and then allow it to dry naturally out of direct sunlight.
5. Check to be sure the seat belt retracts and pulls out correctly.



ADVICE

- If the above-described upkeep operations do not improve the operation of the seat belt through the retractor, there is a possibility that the belt is making contact with the door pillar trim. In this case, arrange for inspection and maintenance to be carried out by your Isuzu Dealer.
- If the belt is not winding and unwinding correctly, or if inspection reveals problems such as loose mountings, metal parts deformation, webbing damage, fraying or discoloration, arrange for replacement to be carried out by your Isuzu Dealer.

Fabric Seat Covering and Carpet Care

Remove dirt and dust using a home-use electric vacuum cleaner.

Do not remove the carpet. Use standard household cleaning products and methods to remove stains from food, drink and the like.

Be sure to use neutral detergents or cleaning products indicated as higher alcohol based detergents.

Notes

Notes



Notes

MAINTENANCE DATA

• Inspection and Maintenance	7-159
• Maintenance Schedule Validation	7-164
• Recommended Lubricants and Diesel Fuels	7-172



Inspection and Maintenance

For safe and economy driving, we recommend that you have your vehicle inspected and serviced regularly according to the schedule indicated in this chapter.

Maintenance Schedule

To drive your vehicle safely and at minimum cost, it is essential to have your vehicle regularly inspected and serviced at your Isuzu Dealer as per the specified maintenance schedule.

Contact your Isuzu Dealer for inspection that requires disassembly and/or special equipment.

Letters Used to Indicate Maintenance Service Types

I : Inspect, clean, or repair or replace as required

A: Adjust

R: Replace

T: Tighten to the specified torque

L: Lubricate



ADVICE

- When inspecting the items listed below, also inspect the routine inspection items as well.

*: Your vehicle needs to be maintained more often if it is driven in severe conditions.

Maintenance schedule for severe-condition operations

→ Refer to page 7-162

ISUZU NLR, NNR, NPR, NPS & NQR MAINTENANCE SCHEDULE

I = Inspect, clean, correct, replace as necessary R = Replace

T = Retighten to specified torque L = Lubricate A = Adjust

* : Refer to "Maintenance schedule under severe operating conditions" on next page.

SERVICE INTERVAL: x 1,000 kilometres or years or hours	Initial	Every				
	5	15	30	45	60	120
	0.1	0.5	1	1.5	2	4
	100	300	600	900	1200	2400
ENGINE & DRIVE LINE						
*Engine oil	R	R				
*Engine oil filter		R				
*Fuel filters			R			
*Air filter element/s	I	I		R		
*Manual transmission oil	I	I		R		
*Transfer case oil	R	I		R		
*Differential oil	R	I		R		
*Clutch Fluid (Automated manual Transmission)				R		
Engine drive belts	I	I				
Valve clearances	A				A	
*Power steering fluid	I	I				R
*Exhaust pipes & mounting, exhaust brake operation	T/I		I			
*Perform manual regeneration, check exhaust pressure and clean DPD filter if required	I					I
Replace DPD pressure sensor hoses				R		
Turbo charger, intercooler, intake system air duct connections and gaskets	I	I				
All coolant hoses & coolant concentration (50%)	I	I				
Coolant	Replace every 2 years when using standard LLC (green) OR Replace every 5 years when using ELC (orange)					
Pressure test cooling system	I	I				
CHASSIS						
Clutch and Brake fluid		I			R	
Brake hydra booster fluid (if applicable)	I	I			R	
*Brake linings/Drums or brake pads/ rotors for wear	I	I				
*Brake pedal travel and freeplay	I	A				
*Brake pipes and hoses	I	I				
Park brake cables for wear and damage	I	I				

SERVICE INTERVAL: x 1,000 kilometres or years or hours	Initial	Every				
	5	15	30	45	60	120
	0.1	0.5	1	1.5	2	4
	100	300	600	900	1200	2400
*Park brake function and lever travel	I	I				
Park brake drum, linings and ratchet for wear or damage	I	I				
Gear control mechanism	I	I				
*Clutch pedal travel & free play	I	A				
*All grease points	L	L				
*Universal joints & sliding sleeve	L	L				
*Steering components	I	I				
Steering wheel free play	I	I				
Inspect power steering hoses	I	I				
Wheel alignment / front wheel toe-in	I			I		
*Front and rear suspension for wear or damage.	I	I				
*King pins	L	L				
Shock absorbers for fluid leaks and operation	I	I				
Inspect coil springs and ball joints (independent suspension models only)	I	I				
*Front & rear wheel bearing grease					R	
Wheel nuts for tension	T	T				
Tyre wear, pressures & rotation	I	I				
Battery specific gravity and terminal condition	I	I				
Body mount bolts and nuts (if applicable)	T	T				
*General Inspection: Fuel, brake, cooling, oil, air & exhaust systems for leaks. All fluid levels.	I	I				
CAB						
Cab suspension & tilt operation	I	I				
Operation of all electrical devices, A/C, heater & warning lights	I	I				
Connect Isuzu diagnostic tool, check, note and/or repair any codes recorded	I	I	I	I	I	I
ROAD TEST						
Operation of steering, brakes, exhaust brake, engine, transmission, clutch	I	I				

*: Refer to "Maintenance schedule under severe operating conditions" on next page.

MAINTENANCE SCHEDULE UNDER SEVERE OPERATING CONDITIONS

- A: Repeated short trips with extensive idling and/or where the engine does not reach normal operating temperature. Also applications involving descending or ascending steep gradients. (Examples may be Concrete Agitators, Tow trucks, Concrete Pumpers, Road Patchers, mine site trucks)
- B: Driving on rough/loose surface roads (More than 10% of operation) or operating in any harsh environment/application likely to cause accelerated wear and tear. (Examples may be Tipplers travelling in and out of quarries, Farm trucks, logging trucks, Trucks that run on poorly made rural roads, Trucks involved in the mining industry)
- C: Driving on dusty/muddy or corrugated roads. (Examples may be Mine site trucks, 4WD bus conversions, Emergency Service trucks, Drill rigs)
- D: Driving in extremely cold and/or hot weather. (Less than 0 Deg. C or greater than 40 Deg. C)

Item	Interval	Condition			
		A	B	C	D
Engine oil	Change every 10,000 km (200hrs)	*		*	*
Engine oil filters	Replace every 10,000 km (200hrs)	*		*	*
Fuel filters	Replace every 10,000 km (200hrs)	*		*	*
Air filter elements	Inspect every 5,000 km (100hrs) and replace as required		*	*	
Manual transmission oil	Change every 30,000 km (600hrs)	*	*	*	*
Transfer case oil	Change every 15,000 km (300hrs)			*	*
Differential oil	Change every 30,000 km (600hrs)		*	*	*
Clutch (Automated Manual Transmission)	Change every 15,000 km (300hrs)	*		*	*
Power steering fluid	Change every 45,000 km (900hrs)	*	*	*	*
Exhaust pipes & mounting, exhaust brake operation	Inspect every 10,000 km (200hrs)		*	*	
Perform manual regeneration, check exhaust pressure and clean DPD filter if required	Inspect every 30,000 km (600hrs)	*		*	*
Front and rear wheel bearing grease/oil	Inspect every 10,000 km (200hrs)		*	*	*
All grease points	Grease every 5,000 km (100hrs)	*	*	*	*
Universal joints & splines	Grease every 5,000 km (100hrs)	*	*	*	*

Item	Interval	Condition			
		A	B	C	D
King pins	Grease every 5,000 km (100hrs)	*	*	*	*
Steering linkage for damage, looseness and excessive play	Inspect every 5,000 km (100hrs)		*	*	
Brake lining/pad wear	Inspect every 5,000 km (100hrs)	*	*	*	*
Brake drum/rotor for wear or damage	Inspect every 15,000 km (300hrs)	*	*	*	*
Brake pedal travel and free play	Inspect every 5,000 km (100hrs)	*	*	*	*
Brake pipes and hoses	Inspect every 5,000 km (100hrs)	*	*	*	*
Park brake function and lever travel	Inspect every 5,000 km (100hrs)	*	*	*	*
Clutch pedal travel and free play	Inspect every 5,000 km (100hrs)	*		*	
Front and rear suspension for wear and damage	Inspect every 5,000 km (100hrs)		*	*	*
General Inspection: Fuel, brake, cooling, oil, air & exhaust systems for leaks. All fluid levels	Inspect every 5,000 km (100hrs)		*	*	

Maintenance Schedule Validation

New Vehicle Preparation Validation	Preparation carried out; at kilometres on (date)..... Delivering Dealer
5,000 kilometre or 0.1 year	Service carried out; atkilometres on (date)..... Servicing Dealer
15,000 kilometres or 0.5 year	Service carried out; atkilometres on (date)..... Servicing Dealer
30,000 kilometres or 1 year	Service carried out; atkilometres on (date)..... Servicing Dealer
45,000 kilometres or 1.5 years	Service carried out; atkilometres on (date)..... Servicing Dealer
60,000 kilometres or 2 years	Service carried out; atkilometres on (date)..... Servicing Dealer
75,000 kilometres or 2.5 years	Service carried out; atkilometres on (date)..... Servicing Dealer
90,000 kilometres or 3 years	Service carried out; atkilometres on (date)..... Servicing Dealer

MAINTENANCE SCHEDULE VALIDATION

<p>105,000 kilometres or 3.5 years</p>	<p>Service carried out; atkilometres on (date)..... Servicing Dealer</p>
<p>120,000 kilometres or 4 years</p>	<p>Service carried out; atkilometres on (date)..... Servicing Dealer</p>
<p>135,000 kilometres or 4.5 years</p>	<p>Service carried out; atkilometres on (date)..... Servicing Dealer</p>
<p>150,000 kilometres or 5 years</p>	<p>Service carried out; atkilometres on (date)..... Servicing Dealer</p>
<p>165,000 kilometres or 5.5 years</p>	<p>Service carried out; atkilometres on (date)..... Servicing Dealer</p>
<p>180,000 kilometres or 6 years</p>	<p>Service carried out; atkilometres on (date)..... Servicing Dealer</p>
<p>195,000 kilometres or 6.5 years</p>	<p>Service carried out; atkilometres on (date)..... Servicing Dealer</p>
<p>210,000 kilometres or 7 years</p>	<p>Service carried out; atkilometres on (date)..... Servicing Dealer</p>

MAINTENANCE SCHEDULE VALIDATION

225,000 kilometres or 7.5 years	Service carried out; atkilometres on (date)..... Servicing Dealer
240,000 kilometres or 8 years	Service carried out; atkilometres on (date)..... Servicing Dealer
255,000 kilometres or 8.5 years	Service carried out; atkilometres on (date)..... Servicing Dealer
270,000 kilometres or 9 years	Service carried out; atkilometres on (date)..... Servicing Dealer
285,000 kilometres or 9.5 years	Service carried out; atkilometres on (date)..... Servicing Dealer
300,000 kilometres or 10 years	Service carried out; atkilometres on (date)..... Servicing Dealer
315,000 kilometres or 10.5 years	Service carried out; atkilometres on (date)..... Servicing Dealer
330,000 kilometres or 11 years	Service carried out; atkilometres on (date)..... Servicing Dealer

MAINTENANCE SCHEDULE VALIDATION

<p>345,000 kilometres or 11.5 years</p>	<p>Service carried out; atkilometres on (date)..... Servicing Dealer</p>
<p>360,000 kilometres or 12 years</p>	<p>Service carried out; atkilometres on (date)..... Servicing Dealer</p>
<p>375,000 kilometres or 12.5 years</p>	<p>Service carried out; atkilometres on (date)..... Servicing Dealer</p>
<p>390,000 kilometres or 13 years</p>	<p>Service carried out; atkilometres on (date)..... Servicing Dealer</p>
<p>405,000 kilometres or 13.5 years</p>	<p>Service carried out; atkilometres on (date)..... Servicing Dealer</p>
<p>420,000 kilometres or 14 years</p>	<p>Service carried out; atkilometres on (date)..... Servicing Dealer</p>
<p>435,000 kilometres or 14.5 years</p>	<p>Service carried out; atkilometres on (date)..... Servicing Dealer</p>
<p>450,000 kilometres or 15 years</p>	<p>Service carried out; atkilometres on (date)..... Servicing Dealer</p>

INTERMEDIATE/SEVERE/ENGINE HOURS VALIDATION

<p>Intermediate/Severe/Engine Hours Service carried out; at.....kilometres orhours, on (date).....</p> <p>Servicing Dealer</p>
<p>Intermediate/Severe/Engine Hours Service carried out; at.....kilometres orhours, on (date).....</p> <p>Servicing Dealer</p>
<p>Intermediate/Severe/Engine Hours Service carried out; at.....kilometres orhours, on (date).....</p> <p>Servicing Dealer</p>
<p>Intermediate/Severe/Engine Hours Service carried out; at.....kilometres orhours, on (date).....</p> <p>Servicing Dealer</p>
<p>Intermediate/Severe/Engine Hours Service carried out; at.....kilometres orhours, on (date).....</p> <p>Servicing Dealer</p>
<p>Intermediate/Severe/Engine Hours Service carried out; at.....kilometres orhours, on (date).....</p> <p>Servicing Dealer</p>
<p>Intermediate/Severe/Engine Hours Service carried out; at.....kilometres orhours, on (date).....</p> <p>Servicing Dealer</p>
<p>Intermediate/Severe/Engine Hours Service carried out; at.....kilometres orhours, on (date).....</p> <p>Servicing Dealer</p>
<p>Intermediate/Severe/Engine Hours Service carried out; at.....kilometres orhours, on (date).....</p> <p>Servicing Dealer</p>

INTERMEDIATE/SEVERE/ENGINE HOURS VALIDATION

Intermediate/Severe/Engine Hours Service carried out; at.....kilometres orhours, on (date)..... Servicing Dealer
Intermediate/Severe/Engine Hours Service carried out; at.....kilometres orhours, on (date)..... Servicing Dealer
Intermediate/Severe/Engine Hours Service carried out; at.....kilometres orhours, on (date)..... Servicing Dealer
Intermediate/Severe/Engine Hours Service carried out; at.....kilometres orhours, on (date)..... Servicing Dealer
Intermediate/Severe/Engine Hours Service carried out; at.....kilometres orhours, on (date)..... Servicing Dealer
Intermediate/Severe/Engine Hours Service carried out; at.....kilometres orhours, on (date)..... Servicing Dealer
Intermediate/Severe/Engine Hours Service carried out; at.....kilometres orhours, on (date)..... Servicing Dealer
Intermediate/Severe/Engine Hours Service carried out; at.....kilometres orhours, on (date)..... Servicing Dealer
Intermediate/Severe/Engine Hours Service carried out; at.....kilometres orhours, on (date)..... Servicing Dealer

INTERMEDIATE/SEVERE/ENGINE HOURS VALIDATION

Intermediate/Severe/Engine Hours Service carried out; at.....kilometres orhours, on (date)..... Servicing Dealer
Intermediate/Severe/Engine Hours Service carried out; at.....kilometres orhours, on (date)..... Servicing Dealer
Intermediate/Severe/Engine Hours Service carried out; at.....kilometres orhours, on (date)..... Servicing Dealer
Intermediate/Severe/Engine Hours Service carried out; at.....kilometres orhours, on (date)..... Servicing Dealer
Intermediate/Severe/Engine Hours Service carried out; at.....kilometres orhours, on (date)..... Servicing Dealer
Intermediate/Severe/Engine Hours Service carried out; at.....kilometres orhours, on (date)..... Servicing Dealer
Intermediate/Severe/Engine Hours Service carried out; at.....kilometres orhours, on (date)..... Servicing Dealer
Intermediate/Severe/Engine Hours Service carried out; at.....kilometres orhours, on (date)..... Servicing Dealer
Intermediate/Severe/Engine Hours Service carried out; at.....kilometres orhours, on (date)..... Servicing Dealer

INTERMEDIATE/SEVERE/ENGINE HOURS VALIDATION

Intermediate/Severe/Engine Hours Service carried out; at.....kilometres orhours, on (date)..... Servicing Dealer
Intermediate/Severe/Engine Hours Service carried out; at.....kilometres orhours, on (date)..... Servicing Dealer
Intermediate/Severe/Engine Hours Service carried out; at.....kilometres orhours, on (date)..... Servicing Dealer
Intermediate/Severe/Engine Hours Service carried out; at.....kilometres orhours, on (date)..... Servicing Dealer
Intermediate/Severe/Engine Hours Service carried out; at.....kilometres orhours, on (date)..... Servicing Dealer
Intermediate/Severe/Engine Hours Service carried out; at.....kilometres orhours, on (date)..... Servicing Dealer
Intermediate/Severe/Engine Hours Service carried out; at.....kilometres orhours, on (date)..... Servicing Dealer
Intermediate/Severe/Engine Hours Service carried out; at.....kilometres orhours, on (date)..... Servicing Dealer
Intermediate/Severe/Engine Hours Service carried out; at.....kilometres orhours, on (date)..... Servicing Dealer

Recommended Fluids, Lubricants and Diesel Fuels

It is extremely important to select correct lubricants and diesel fuels so that your Isuzu vehicle demonstrates its full performance over years.

Top up the lubricants in accordance with the Maintenance Schedule specified for your vehicle. Use Isuzu genuine lubricants or those recommended in the list below.

The lubricant change intervals specified in the Maintenance Schedule and the terms and conditions of the new vehicle warranty assume the use of Isuzu genuine or Isuzu recommended lubricants listed below.

Diesel Engine (Euro 4 with DPD)	ACEA E6, E7 / API CJ-4 SM, low ash: SAE 10W40, 15W40
Manual Transmission and Transfer Case	Same as engine oil
Clutch - Automated Manual Transmission (AMT)	Isuzu AMT FLUID or equivalent
Differential	API GL5, SAE 85W140 (plus Isuzu additive for LSD, P/N 8010523580)
Coolant	LLC (green), HN2217, ELC (orange), GM6277m
Power Steering Fluid	DEXRON® III
Hydra Booster Fluid (NQR only)	DEXRON® III
Wheel Bearings	Multipurpose Grease NLGI No.2
Grease Fittings	Multipurpose Grease NLGI No.2
Clutch and Brake Fluid	API Dot. 4



NOTE

- The oils recommended in the "Diesel Engine Crankcase" list can also be used for DPD-equipped vehicles. If you use a low ash content engine oil, increased exhaust pressure may extend the required distance between DPD filter cleanings.

DIESEL FUEL / APPLICABLE STANDARD (Sulfur content below 50 ppm)

Japanese Industrial Standards	Based on K2204 Diesel Fuel
Deutsche Industrie Normen (DIN)	Based on EN590 : 2004
American Society for Testing and Materials (ASTM)	Based on D975-04c NO.1-D S15 or NO.2-D S15 (below 15 ppm)
British Standards (BS)	Based on EN590 : 2004

**ADVICE**

- Do not use fuels other than those listed above. Doing so may adversely affect the engine.

Notes

• Troubleshooting	8-2
• When the Vehicle Breaks Down during Driving	8-7
• When the Tyre Goes Flat	8-8
• When the Engine Stops While Driving	8-9
• When the Engine Stalls and Cannot be Restarted	8-10
• When the Brakes Do not Work	8-11
• When the Battery Goes Flat	8-12
• When the Fuel Runs Out	8-14
• When the Warning Light Comes On	8-16
• When the Engine Overheats	8-22
• When the Meter Shows an Abnormality	8-23
• When the Bulb Does not Come On	8-24
• Replacing the Fuses and Relays	8-42
• When Your Vehicle is Involved in an Accident	8-48
• When Driving on Bad Roads	8-48
• When Towing	8-49

Troubleshooting

Performing regular inspections and maintenance prevents damage. Be sure to perform inspections and maintenance at regular intervals. Also, quickly rectify any fault in the vehicle (even a small fault) to prevent it from becoming more serious.

If a symptom shown in the following table occurs, perform inspections and take corrective action in accordance with the table. If you are unable to perform a repair, the corrective action shown in the table does not eliminate a symptom or you can't locate a fault, contact the nearest Isuzu Dealer.



ADVICE

- Any item for which there is a © in the "Corrective action" column requires repairs and adjustments. Contact the nearest Isuzu Dealer.

Symptom		Cause	Corrective action	Reference page
Engine doesn't start	Starter doesn't turn over, or is weak	Flat batteries	Recharge or replace	8-12
		Battery terminals detached, loose or corroded	After repairing corroded section, connect the terminals firmly	—
		Starter ground wire terminal detached, loose or corroded	After repairing corroded section, connect the terminals firmly	—
		Engine oil viscosity too high	Change to oil with proper viscosity	6-18
		Starter or electrical system is faulty	⊙	—
		Gearshift lever is not in the "N" position (Other than manual transmission vehicle)	Place gearshift lever in "N" position. (AMT vehicles)	4-82
		Haven't depressed brake pedal or apply parking brake (AMT vehicles)	Depress brake pedal or apply parking brake	4-82
	Starter turns over	No fuel	Make sure there are no fuel leaks, and then add fuel	—
		Air in the fuel system	Bleed fuel system	8-15
		Fuel filter clogged	Replace filter	7-54
		Fuel is frozen	Warm fuel pipe with hot water or wait until it gets warmer	—
		Common rail system is faulty	⊙	—
Preheating system is faulty		⊙	—	
Engine starts, but immediately stops	Idling speed too low	Adjust the idling speed	4-62	
	Fuel filter is clogged	Replace filter	7-54	
	Air cleaner is clogged	Clean or replace element	7-50 7-52	
	Common rail system is faulty	⊙	—	
Unsteady engine speed	There is water or air in the fuel system	Bleed the system	8-15	
	Fuel system is faulty	⊙	—	

Symptom	Cause	Corrective action	Reference page
White or black exhaust smoke	Engine not sufficiently warmed up	Allow engine to warm up sufficiently	4-63
	Excessive engine oil	Correct oil level	7-22
	Air cleaner clogged	Clean or replace element	7-50 7-52
	Fuel system is faulty	⊙	—
	DPD is faulty	⊙	—
Engine is overheating	No coolant	Add coolant	7-36
	Front of radiator is clogged with dirt	Clean with a soft bristle brush	—
	Radiator cap not sufficiently tightened	Make sure it is firmly tightened	—
	Fan belt loose	Adjust the tension or replace the belt	7-45
	Coolant dirty	Clean the radiator interior or change coolant	7-37
	Fan clutch is faulty	⊙	—
	Radiator cap dirty or faulty	Clean or replace	—
Oil pressure is low	Improper engine oil viscosity	Change to oil with proper viscosity	6-18
	Engine oil level too low	Add engine oil	7-26
	Engine inner components are faulty	⊙	—
	Meter, indicator/warning lights or switches faulty	⊙	—

Symptom	Cause	Corrective action	Reference page
Not enough engine power	Parking brake not fully released	Make sure it is fully released	—
	Brake dragging	⊙	—
	Clutch slipping	Adjust clutch free play (Manual transmission model)	7-104
		Add clutch fluid (AMT Model)	7-109
	Air cleaner clogged	Clean or replace element	7-50 7-52
	Fuel filter clogged	Replace the filter	7-54
	Engine control system faulty	⊙	—
	Common rail system faulty	⊙	—
	Engine faulty	⊙	—
DPD clogged	⊙	—	
Brakes not effective	Drum-to-lining gap too large	⊙	—
	Air in brake fluid	⊙	—
	Brake system failure	⊙	—
Uneven braking	Unbalanced air pressure in tyres	Adjust to proper air pressure	7-74
	Tyre unevenly worn	Replace tyre	7-88
	Unbalanced drum-to-lining gap of the wheels	⊙	—
	Poor wheel alignment	⊙	—
Exhaust brake not working	The electrical system is faulty	⊙	—
Steering wheel hard to turn	Loaded too far forward	Load properly	—
	Power steering fluid level too low	Add fluid	7-122
	Insufficient air in front tyres	Adjust to proper inflation pressure	7-80

Symptom		Cause	Corrective action	Reference page
Excessive play in the steering wheel		Wheel studs and nuts loose	Tighten to the specified torque	7-96
		Unbalanced inflation pressure in the tyres	Adjust to proper inflation pressure	7-74
		Unbalanced tyres	⊙	—
		Excessive steering wheel play	⊙	—
Poor steering wheel return		Poor lubrication in the steering mechanisms	Lubricate the mechanism	—
		Poor wheel alignment	⊙	—
Clutch disengages poorly		Insufficient clutch fluid	Add fluid	7-101
		Excessive clutch pedal free play	Adjust to proper level	7-104
Loud or abnormal noises	From the transmission	Insufficient transmission oil	Add oil	7-107
		Transmission inner components faulty	⊙	—
	From differential	Insufficient differential gear oil	Add oil	7-113 7-115
		Differential inner components faulty	⊙	—
	From the suspension	Spring pins, shackles, or stoppers worn	⊙	—
	From the propeller shaft	Poor lubrication in each component	Lubricate them	7-124
		Splines or bearings worn	⊙	—
	From the transfer case	Insufficient transfer oil	Add oil	7-118
Transfer inner components faulty		⊙	—	

When the Vehicle Breaks Down during Driving

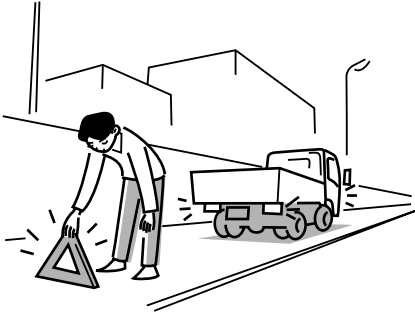

1. Operate the hazard warning flasher and pull the vehicle immediately over to a safe place that doesn't impede traffic (shoulder, verge). Place the triangle reflectors to alert other traffic to the presence of your vehicle.
2. Have the other passengers get out and wait in a safe place.
3. Walk to a safe place and take appropriate measures by using the closest telephone, etc.

WARNING

[If there is a fuel leak]

- Leaking fuel from the vehicle is dangerous due to possible combustion or explosion. Stop the engine immediately.

When the Tyre Goes Flat

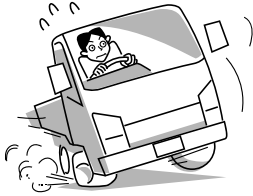

When the tyre gets flat while driving, avoid hard braking, hold on to the steering wheel firmly and stop the vehicle.

The tyre should be changed on a flat space to prevent obstructing other vehicles or pedestrians.



WARNING

- If you continue to drive on a flat tyre, undue force will be applied to the wheel studs, possibly causing the studs to break and the wheel to come off.

Spare Tyre → Refer to page 7-98

Handling the Jack → Refer to page 7-128

Changing Tyres → Refer to page 7-88

When the Engine Stops While Driving

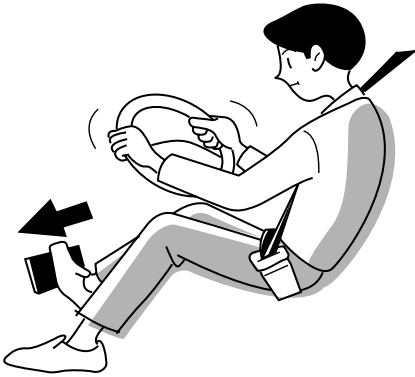

As the brake booster will no longer operate, brake effectiveness will be reduced. If the engine cannot be started, promptly have the vehicle inspected and repaired by the nearest Isuzu Dealer.

If the engine stopped because the vehicle ran out of fuel while driving, refueling alone will not be enough to restart the engine. Bleed the fuel system after refueling the vehicle.

When the Fuel Runs Out

→ Refer to page 8-14

WARNING

- Vehicle operations will change, so stop the vehicle in a safe place with the following in mind.
 - The power steering system will not work so the steering wheel will be hard to turn. It will require more strength than during normal operation.
 - As the brake booster will no longer be functional, brake effectiveness will be greatly reduced. Be sure to apply more pressure than usual to the brake pedal.

When the Engine Stalls and Cannot be Restarted

- In manual transmission models, place the gearshift lever in the "N" position and push the vehicle to a safe place.
- In AMT vehicles, place the gearshift lever in the "N" position, and if the shift indicator shows "N", push the vehicle to a safe place. If the shift indicator displays a shift position other than "N", place the emergency switch to "ON" and the gearshift lever into the "N" position. Then, make sure that the shift indicator displays "N" and push the vehicle to a safe place.

If the AMT System Fails

→ Refer to page 4-95



NOTE

- For vehicles with hill-start-aid (HSA), cancel the HSA by pressing the HSA OFF switch.

HSA OFF Switch → Refer to page 4-98



CAUTION

- In case of emergency with manual transmission models, place the gearshift lever in "R (reverse)", "1 (first gear)" or "2 (second gear)" if the starter turns over.
- Then, keep turning the starter switch with your foot off the clutch pedal to move the vehicle.

When the Brakes Do not Work



If the brakes become ineffective unexpectedly, reduce speed by quickly shifting down from third to second to first gear using the gearshift lever. Gradually pull the parking brake lever while firmly holding on to the steering wheel. Stop the vehicle on the side of the road.



CAUTION

- It is very dangerous to suddenly pull the parking brake lever all the way while moving at high speed. Reduce speed first by shifting down and then gradually pull the parking brake lever.



NOTE

- In worst case conditions on a mountain road or similar situations, stop the vehicle by scraping along a guardrail or cliff, or drop the front and rear wheels of one side into a ditch at the side of the road.

When the Battery Goes Flat

Use a jumper cable (sold separately) and the batteries of another vehicle to start the engine in this sequence.



CAUTION

- For safety and the protection of the vehicle, don't push-start the vehicle.
- Make sure that the booster batteries in the vehicle providing the charge have the same voltage as the disabled vehicle.
- Under no circumstances should the battery's positive and negative terminals be put in contact with one another.
- When connecting the cables, under no circumstances should the clips be allowed to touch each other.
- Ask the nearest Isuzu Dealer to recharge the battery.
- Do not disconnect a battery terminal with the engine running. It could cause a breakdown in the electrical system.

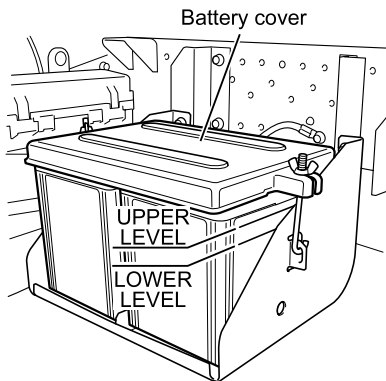

1. Check the battery fluid level in the disabled vehicle.
2. Use a vehicle that has a charged battery with the same voltage.
3. Remove the battery cover and connect the jumper cables in the numbered sequence in the drawing.
4. After connecting the cables, start the engine of the vehicle with the booster battery.
5. Slightly rev up the engine of the vehicle with the booster battery and start the engine of the disabled vehicle.
6. If the engine in the disabled vehicle starts, remove the jumper cables in the reverse sequence as they were connected.

**NOTE**

- When it is difficult to start the engine in a cold area, first start the engine of the vehicle with the booster batteries and a few minutes after that start the engine of the disabled vehicle.

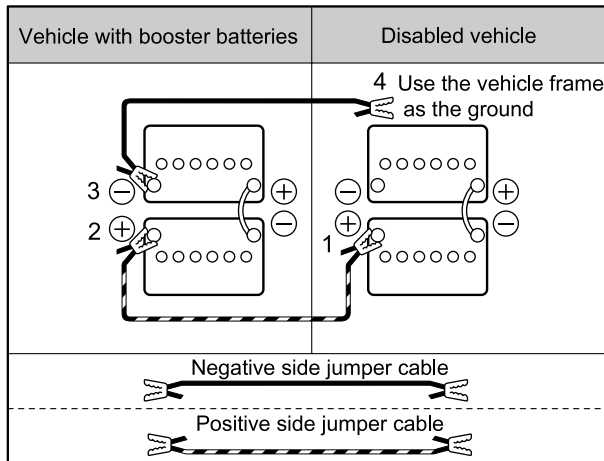
**WARNING**

- Check the battery fluid level before connecting the jumper cables. Usage or charging of the battery when the battery fluid is below the "LOWER LEVEL" can accelerate deterioration, and give rise to dangerous situations such as the generation of heat and may even cause an explosion. Perform the work after adding the battery fluid.
- A vehicle battery generates flammable gas that could explode. Be careful of the following to avoid creating sparks.
 - Do not connect one end of the jumper cable shown in Step 4 in the drawing directly to the battery's negative terminal. Connect the jumper cable to a metal part of the engine that is away from the battery.
 - Do not let the cable connected to the positive terminal come in contact with the cable connected to the negative terminal or the body.
 - Keep flames away from the battery.
- Use care not to become entangled in any belts when connecting the cable.

When the Fuel Runs Out



When the fuel runs out, air will enter the fuel system, so refueling alone will not be enough to restart the engine. Use the following methods to bleed the fuel system.

WARNING

- Wipe off any fuel that adheres to the vehicle body or the engine compartment below the cab. This could cause a fire.

CAUTION

- Before starting the engine, sit in the driver's seat and make sure that the gearshift lever is placed in the "N" position. Alternatively, in the case of the AMT vehicle, make sure that the shift indicator displays "N".
Do not start the engine unless you are sitting in the driver's seat. For example, do not start the vehicle by reaching through the window from outside, or from outside the vehicle with the door open. Pay particular attention to the fact that manual transmission vehicles will move when the engine is started with the transmission in a position other than "N".

Bleeding the Fuel System

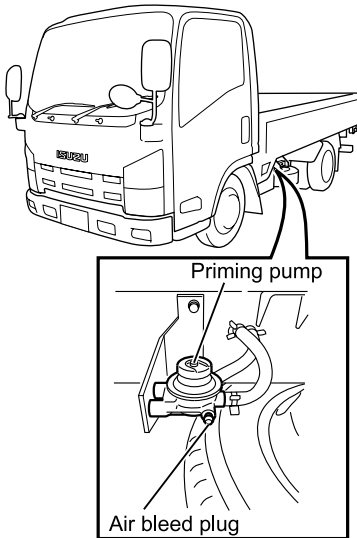

Before starting the engine

1. Place a container beneath the air bleeder plug to receive fuel, and then fully loosen the plug.
2. Operate the priming pump up and down about 20 times until the fuel from the bleeder plug no longer contains air bubbles.
3. Fully retighten the plug and wipe off any fuel that may have adhered to the plug or surrounding area.
4. Operate the priming plug up and down about 10 times to feed air in the fuel system to the fuel supply pump.
5. Turn the starter switch to start the engine.

After starting the engine

1. Without depressing the accelerator pedal, turn the starter switch and start the engine.
2. After the engine has started, allow it to idle for about 5 seconds.
3. Fully depress the accelerator pedal and increase the engine r/min to the maximum speed.
(Repeat this operation several times.)



ADVICE

- Insufficient air bleeding can result in faulty engine operation. Be sure, therefore, to always carry out the procedure described in "After starting the engine".

When the Warning Light Comes On

Brake Booster Warning Light

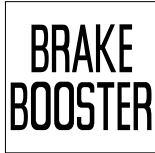

The warning buzzer will sound whenever the brake booster's vacuum becomes insufficient either with the starter switch in the "ON" position or during driving, whenever the hydraulic brake booster (HBB) system becomes faulty, or whenever a problem occurs with the exhaust brake while it is being used. The brake booster warning light will also come on.



CAUTION

- If the warning buzzer should sound during usage of the exhaust brake, immediately park the vehicle in a safe place and take the following action:
 - With the engine still running, turn off the exhaust brake switch. A problem in the exhaust brake system will be confirmed if the buzzer stops sounding several seconds later. Have your vehicle inspected by the nearest Isuzu Dealer.
 - If the warning buzzer continues to sound, the problem will be in the brake booster for the foot (main) brake. Have your vehicle inspected by the nearest Isuzu Dealer immediately.

Brake System Warning Light

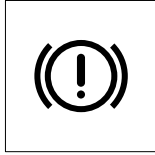

The brake system warning light comes on while the engine is running (after startup) in the following situations:

- Drop in the level of brake fluid (due to brake lining wear or fluid leakage, etc.)
- Abnormality in the charging system (such as a alternator malfunction or either loosening or splitting of the fan belt, etc.)
- On an anti-lock brake system (ABS) model, abnormality in the ABS (the ABS warning light will also come on.)

ABS Warning Light

→ Refer to page 4-37



CAUTION

- If this warning light comes on while the engine is running, immediately stop the vehicle in a safe place well clear of traffic and promptly contact the nearest Isuzu Dealer for inspection.

Alternator Warning Light

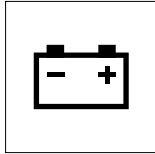

When this warning light comes on, the charging system may have failed. Immediately stop the vehicle in a safe place, perform checks and take corrective action.

Check and Corrective Action

1. Check to see if the fan belt is broken or loose.
2. If the fan belt is loose, adjust the tension.
3. If there is no abnormality in the fan belt, contact the nearest Isuzu Dealer.

Fan Belt → Refer to page 7-45



CAUTION

- Do not drive the vehicle when the warning light is on. The battery can be discharged.



NOTE

- Since disassembling is required to replace the fan belt, have it performed by the nearest Isuzu Dealer.

Engine Oil Pressure Warning Light

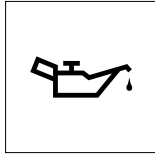

When this warning light comes on, the oil pressure is too low.

Immediately stop the vehicle in a safe place, stop the engine, perform checks and then take corrective action.

Check and Corrective Action

1. Check the engine oil level.
2. If the engine oil level is too low, check for leaks and add oil.
3. When the oil level is normal and there are no oil leaks, the oil filter may be clogged.
Replace the oil filter.
4. When the oil level is normal and the oil filter is not clogged, but there are oil leaks, contact the nearest Isuzu Dealer.

Engine Oil → Refer to page 7-22

Changing the Engine Oil and Oil Filter → Refer to page 7-28



CAUTION

- Do not drive the vehicle when the warning light is on. It could damage the engine.



NOTE

- In winter, when the engine oil temperature is low and the oil viscosity is high, the light might come on for a time. It will go out when the engine warms up.

SRS Airbag Warning Light V

The following situations indicate an abnormality in a pretensioner seat belt and SRS airbag system.

- When the SRS airbag warning light comes on during driving.
- When the starter switch is placed in the "ON" position and the warning light does not come on.
- When the starter switch is placed in the "ON" position, the warning light comes on, but does not go out after flashing 7 times.

**CAUTION**

- If there is an abnormality in seat belts with a pretensioner and the SRS airbag system, they may not work normally. Have the system checked by the nearest Isuzu Dealer.

**NOTE**

- It is normal for the warning light to come on, flash seven times, and then go out when the starter switch is placed in the "ON" position. The SRS airbag warning light may come on again immediately after the engine is started, but it is normal if it goes out after flashing seven times.
- The SRS airbag warning light may come on suddenly if the starter switch is placed in the "ACC" position or electrical equipment is operated, but this is not abnormal.

Check Engine Warning Light

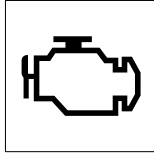

If this warning light comes on while the engine is running, there may be a problem with the engine electronic control system. Since checking and repairing the control system is required, immediately contact the nearest Isuzu Dealer.

HSA Indicator Light



HSA Indicator Light
→ Refer to page 4-52

ABS Warning Light

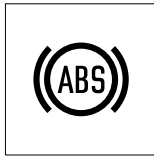

ABS Warning Light
→ Refer to page 4-37

ASR Indicator Light

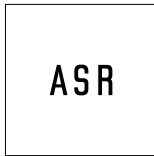

ASR Indicator Light
→ Refer to page 4-53

AMT Warning Light

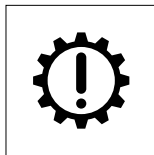

AMT Warning Light
→ Refer to page 4-44

When the Engine Overheats

If engine power drops and the needle on the engine coolant temperature gauge goes up above the upper limit of the safety zone and enters the "H" zone, the engine is overheating. The engine overheat warning light will come on and the warning buzzer will sound. Take the following corrective actions immediately.

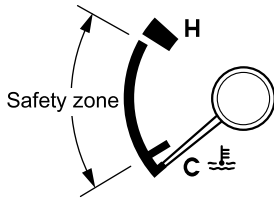

Model without MID

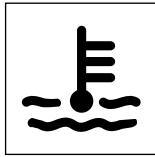

Model with MID



1. Operate the hazard warning flasher and pull the vehicle immediately over to a safe place that doesn't impede traffic (shoulder, verge) and park it.
2. Lower the temperature of the engine for a while with the engine idling.



ADVICE

- Do not stop the engine immediately. Otherwise, the engine may seize.
3. When the needle of the engine coolant temperature gauge returns to the middle of the safety zone, stop the engine.



WARNING

- Even when the engine has been stopped, the coolant in the radiator remains under pressure. Immediately removing the radiator cap could cause steam or hot water to blow out, and you could be scalded as a result. The coolant in the reserve tank may also be hot. Immediately removing the cap could cause hot water to blow out, and possibly scald you.
- When removing the radiator cap and reserve tank cap, use a thick cloth to cover the cap and turn it little by little.

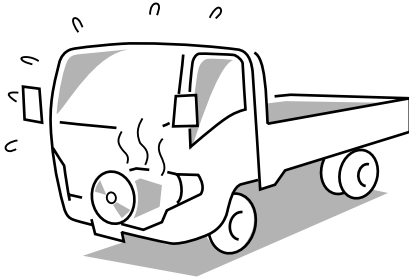
**ADVICE**

- When the cooling fan for the radiator is not turning, turn off the engine immediately.

4. Check the coolant level in the reserve tank and radiator after the engine has sufficiently cooled. If the level is insufficient, add coolant. Also, check to see if the fan belt is loose or has been damaged.

**ADVICE**

- Make sure that the needle on the engine coolant temperature gauge is below "C" before adding coolant. Adding coolant when the engine is not sufficiently cool could cause a breakdown in the engine or damage it.
- When tap water only has been used for coolant in an emergency, adjust the coolant concentration as soon as possible.

Engine Coolant → Refer to page 7-34

Fan Belt → Refer to page 7-45

When the Meter Shows an Abnormality

Voltmeter



Briefly press the MID select knob; the voltmeter will be displayed. When the abnormal voltage display (red) is indicated on the multi information display (MID), there may be excessive battery discharge or the alternator may not be working properly. When this occurs, contact the nearest Isuzu Dealer.

Voltmeter → Refer to page 4-22

When the Bulb Does not Come On

1. Check each bulb for blowout.
2. If a bulb has blown out, replace it. Always place the starter switch in the LOCK position and place all the other switches in the OFF position before replacing the blown bulbs.
3. If the bulb has not blown out, the fault may be in the wiring. Contact the nearest Isuzu Dealer.

Bulb Wattage

Position	Lights	Bulb wattage
Front	Halogen headlight High beam/low beam	24V - 75/70W
	Fog light <input type="checkbox"/>	24V - 70W
	Turn signal light (front)	21W
	Clearance light	5W
	Cornering light <input type="checkbox"/>	21W
	Turn signal light (side)	21W
	End outline marker	5W
Rear	Taillight and stop light	5/21W
	Turn signal light	21W
	Back up light	21W
	License plate light	10W (1-light type) 5W (2-light type)
	Rear fog light <input type="checkbox"/>	21W
Interior	Dome light <input type="checkbox"/>	10W
	Rear dome light <input type="checkbox"/>	10W
Roof	Roof-mounted clearance light <input type="checkbox"/>	5W

Contact the nearest Isuzu Dealer when replacing lights that aren't listed here.

**CAUTION**

- Using bulbs with a wattage other than that specified could cause the bulb or the wiring to become hot. This could result in the warping of the lens and case, and it could also lead to the outbreak of fire.
- Bulbs are hot immediately after they go out. When replacing the bulbs, avoid being burned by making sure they are fully cooled.
- Never drive the vehicle with the bulbs not working. This could result in an accident.

**ADVICE**

- When one bulb of a pair of lights, such as a headlight blows out, the other bulb is approaching the end of its useful life. We recommend that both be changed at the same time.

**NOTE**

- For the lights (lighting equipment) such as headlights, inside of the lens can mist up momentarily when driving in the rain or during the car wash. Also, the temperature difference between inside and outside of the lights can sometimes cause the water condensation inside the lens. This is not abnormal because this is the same phenomenon as the windshield or door glass fogs up when it rains. If it is demisted minutes after the light is turned on, things are normal.

Replacing the Headlights

When the bulb has blown out, replace it with a bulb of the specified wattage. Be careful not to excessively tighten the screws when installing.

**ADVICE**

- Do not replace a bulb with other than the specified wattage. This will cause abnormal flashing, particularly for turn signal lights.
- When replacing headlight bulbs, have the headlight aim adjusted at your Isuzu Dealer.

Bulb Wattage → Refer to page 8-24

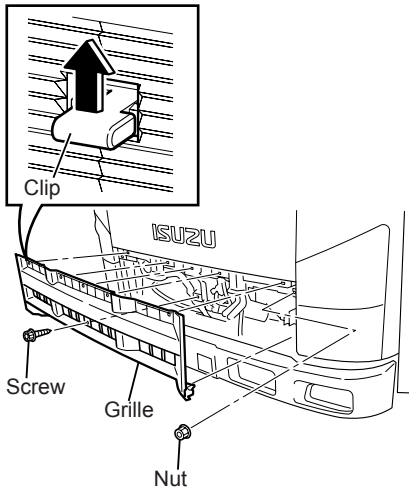

Halogen Headlight (NLR/NNR/NPR/NQR/NPS Models)

1. Remove the screw from the centre of the grille. Push up on the tabs of the five clips on the upper side of the grille and pull the grille toward you to remove it. Loosen the nuts for the turn signal light.

2. Open the front door. Use a phillips head screwdriver to remove the two screws between the door and the cab.

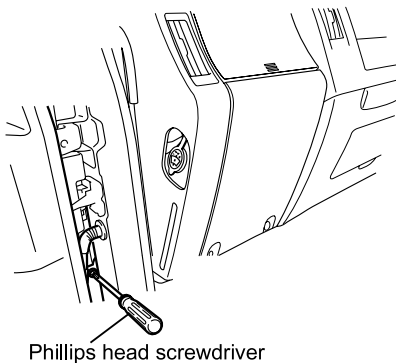

3. Tilt the turn signal light unit down toward the front of the vehicle and remove it.

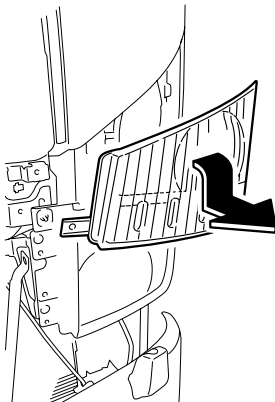

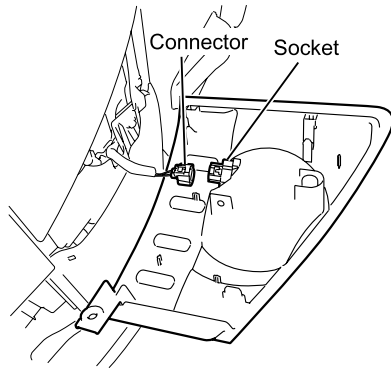

4. Disconnect the connector for the turn signal light and then remove the light.

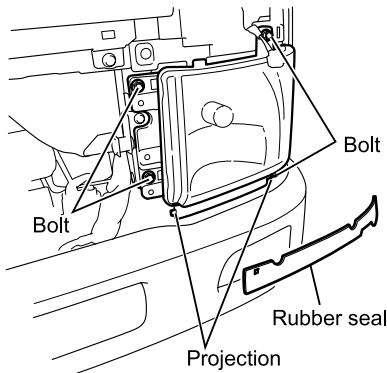

5. Disengage the rubber seals from the two projections at the bottom of the headlight. Remove the four bolts. Then disconnect the connector for the headlight, remove the clearance light unit, and disconnect the headlight leveling connector. Then remove the headlight assembly.

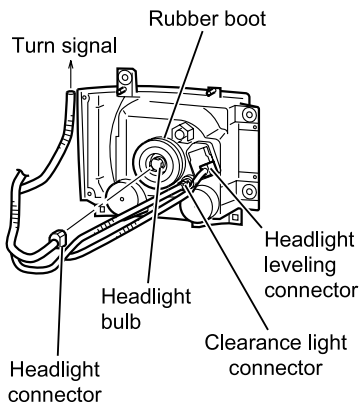

ADVICE

- When removing the headlight connector, pull out the connector while holding the centre portion of the rubber boot. If the headlight connector is pulled out without holding the centre portion of the rubber boot, the bulb will lift up and when the connector is removed, the bulb can hit the reflector by the reactive force of the retaining clip, resulting in the breakage of the bulb.

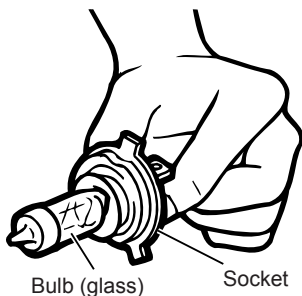
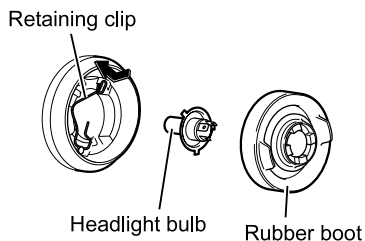

6. Remove the rubber boot. Then push the right side of the clip that holds the bulb in place and slide it upwards to disengage the clip.
7. Pull off the bulb and replace with a new one.
8. After replacing the bulb, install the parts in the reverse order to removal.

**ADVICE**

- Do not touch the glass of the bulb with your hand. Soiling the glass will cause the bulb to blow out.
- When attaching the rubber boot, press in both the outside and inside circumference of it. Make sure that the rubber boot, the headlight assembly, and the bulb are securely installed without any raised section. If the rubber boot is not firmly in place, water could get inside the headlight and lead to a breakdown.

Replacing Clearance Lights, Turn Signal Lights, and Cornering Lights

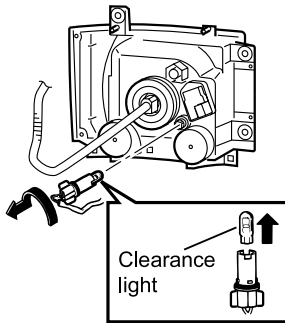

Replacing a Clearance Light (NLR/NNR/NPR/NQR/NPS Models)

1. Refer to "Replacing the Headlights" and remove the headlight assembly.

Replacing the Headlights

→ Refer to page 8-25

2. Pull the bulb out from the clearance light socket and replace with a new one.

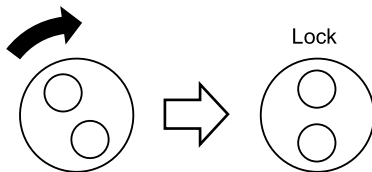

3. To install the lights, perform the same sequence of operations in reverse taking care of the following points:

- Turn the connector clockwise to lock it securely.



ADVICE

- If the socket is not locked securely, water could get inside the light and lead to a breakdown.

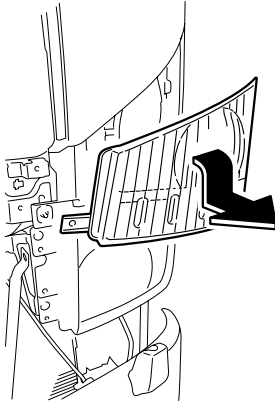

Replacing a Turn Signal Light (NLR/NNR/NPR/NQR/NPS Models)

1. While referring to "Replacing the Headlights", tilt the turn signal light unit down toward the front of the vehicle and remove it.

Replacing the Headlights

→ Refer to page 8-25

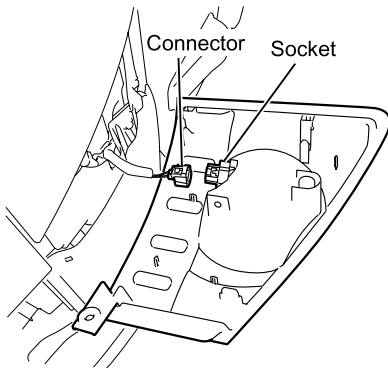

2. Disconnect the connector for the turn signal light and then remove the socket.

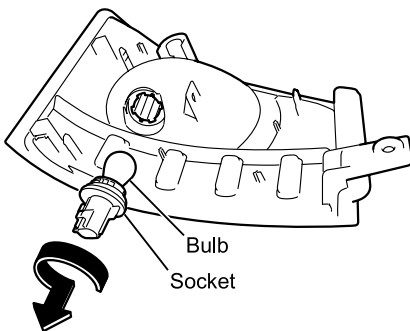

3. Pull off the bulb from the socket and replace with a new one.
4. To install the lights, perform the same sequence of operations in reverse taking care of the following points:
 - Turn the socket clockwise to securely lock it.



ADVICE

- If the socket is not locked securely, water could get inside the light and lead to a breakdown.

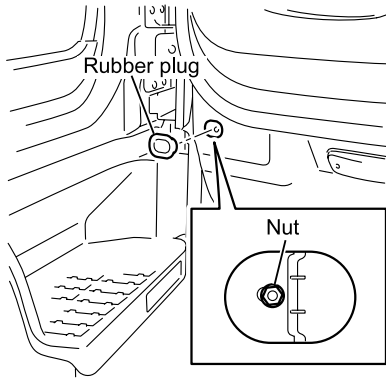

Replacing a Cornering Light or Side Turn Signal Light (NLR/NNR/NPR/NQR/NPS Models)

1. Open the front door, remove the rubber cap in the lower part of the door, and loosen the nut.
2. While sliding the cornering light or side turn signal light toward the front of the vehicle, turn it to expose the rear part of the light. Disengage the clip on the side of the rear of the light from the door panel.

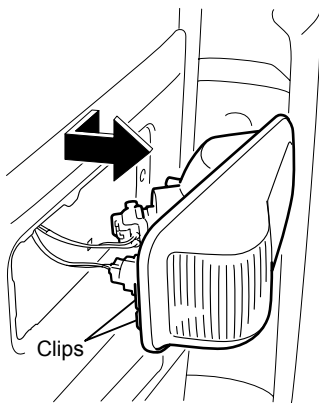
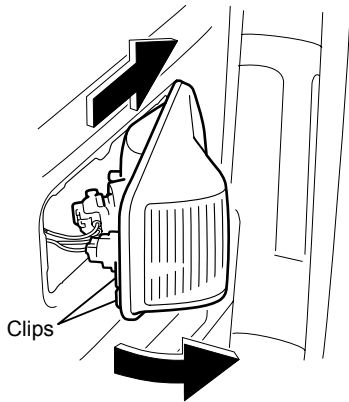

3. When the clip has been removed, pull the light out while sliding it out toward the rear of the vehicle.

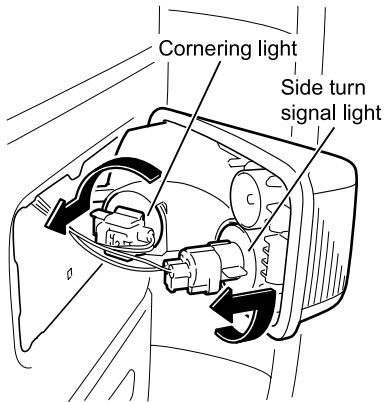

4. Loosen the socket by turning it counterclockwise.
5. Pull the bulb out from the socket and replace with a new one.
6. To install the lights, perform the same sequence of operations in reverse taking care of the following points:
 - a. Turn the socket clockwise to lock securely.

**ADVICE**

- If the socket is not locked securely, water could get inside the light and lead to a breakdown.

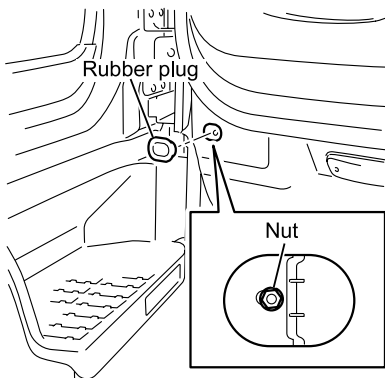
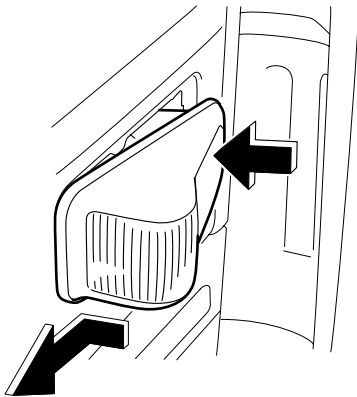

- b. Insert the clip on the back of the rear part of the light into the door panel.
- c. Push the front part of the light into the door panel, and insert the clip on the back of the front part of the light in the door panel.
- d. Open the front door, tighten the nut from the inside of the door, and install the rubber cap.

Replacing the Front Fog Light v

1. Tilt and raise the cab.

WARNING

- Do not touch the lock on the cab support while the cab is tilted. If you touch it, the lock will release.

CAUTION

- Tilt the cab only on a level surface.
- Check the areas in front of and above the cab for sufficient clearance when tilting the cab indoors.
- When tilting the cab, close the doors securely. You should avoid opening or closing the doors when the cab is tilting.
- Confirm that the lock E for the tilt support is securely engaged after the cab is tilted.
- Do not tilt the cab when objects are placed on or in the instrument panel, seats, cup holders, or floor surface.
- Remove any ice or snow accumulating on the top of the bumper before tilting the cab. Failure to do so could result in damage to the bumper, headlights, back panel tray, and other vehicle components.
- When you must open or close a tilted cab's door, securely support the weight of the door while opening or closing it. It is dangerous to release the door when it is being opened or closed. The door could hit you or someone else and cause an injury, or the door could be damaged. Confirm that the door is completely locked after closing it.

Tilting the Cab v → Refer to page 7-12

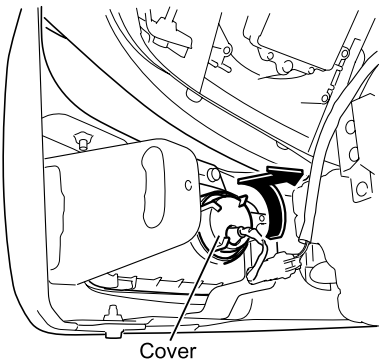

2. Turn the cover counterclockwise to disconnect it. While pushing the clip that holds the bulb in place, slide it downward. Disconnect the connector from the cover while being careful not to damage the clip or pull off the terminal.

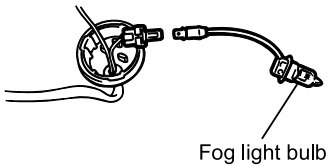

3. Pull out the bulb and replace with a new one.

**ADVICE**

- Do not touch the glass of the bulb with your hand. Soiling the glass will cause the bulb to blow out.
4. To install the lights, perform the same sequence of operations in reverse taking care of the following points:
 - Since there are different notches on the bulb on top and bottom (rounded or square), pay attention to the direction of insertion when installing.
 - The round notch should face up on both the left and right sides.
 - Turn the cover clockwise to lock it. When locking the cover, be sure that the harness will not be caught in the cover.

**ADVICE**

- If the socket is not locked securely, water could get inside the light and lead to a breakdown.

Replacing the Rear Turn Signal Lights, Taillights, Stop Lights, and Back Up Lights

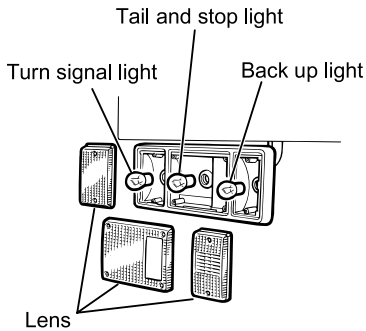

1. Loosen the screws and remove the lens.
2. Loosen the bulb by turning it counterclockwise while pressing on it.
3. To install the lights, follow the removal procedure in reverse.

Replacing the License Plate Light

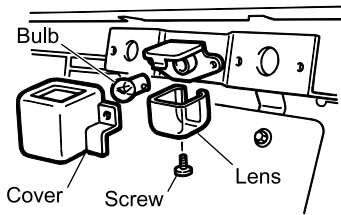

1. Loosen the screws and remove the cover.
2. Remove the lens.
3. Loosen the bulb by turning it counterclockwise while pressing on it.
4. To install the lights, follow the removal procedure in reverse.

Replacing the Rear Fog Light

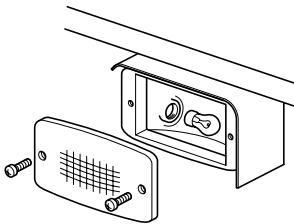

1. Loosen the screws and remove the lens.
2. Loosen the bulb by turning it counterclockwise while pressing on it.
3. To install the lights, follow the removal procedure in reverse.

Replacing the Dome Light

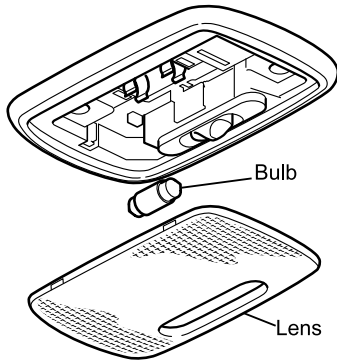

NLR/NNR/NPR/NQR/NPS Models

1. Remove the lens and pull out the bulb.
2. To install the lights, follow the removal procedure in reverse.

Replacing the Roof-Mounted Clearance Light

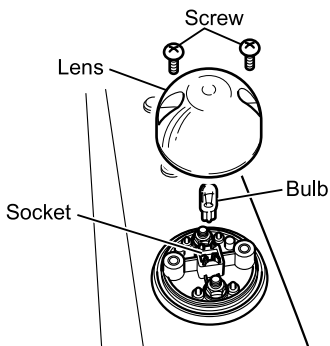

1. Loosen the screws and remove the lens.
2. Remove the bulb and replace it with a new one.
3. To install the lights, follow the removal procedure in reverse.

Replacing the Fuses and Relays

When the lights won't come on or flash, or the equipment in the electrical system does not operate, check to see if a fuse has blown.

The Location of Fuses and Relays

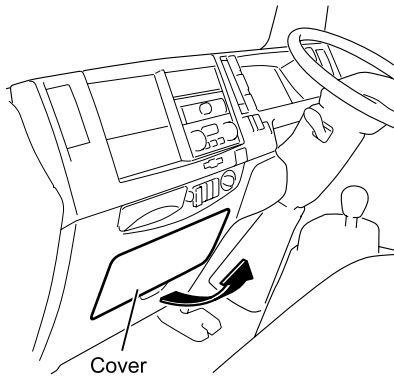

The fuses and relays are located in the lower part of the instrument panel in the centre and in the left rear of the cab. The cover must be opened in order to carry out inspection and replacement. In addition, the cover of the relay box at the rear of the cab must also be opened at this time.

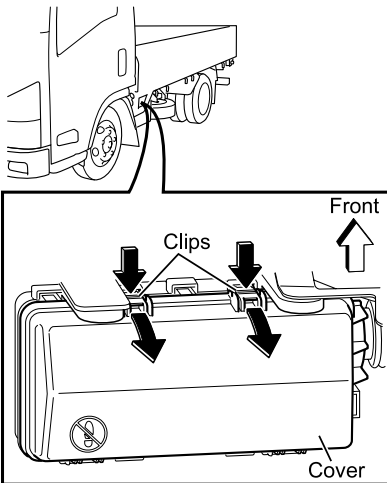

The relay box's cover at the left rear of the cab is opened by pulling upward while pressing the clips of the cover.

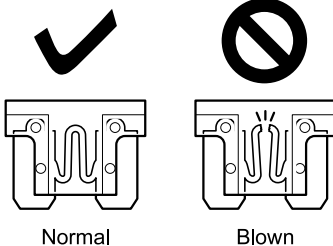
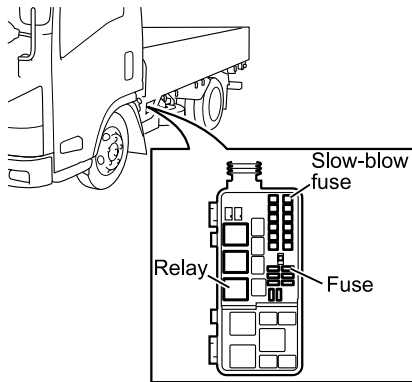
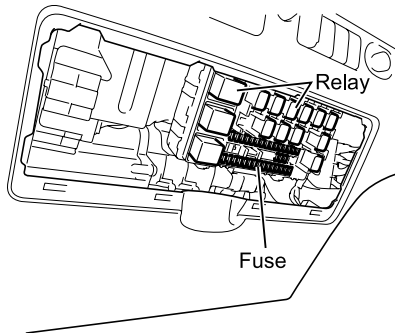

Replacing Fuses

1. Before replacing fuses, be sure to place the starter switch in the "LOCK" position and pull back on the parking brake lever.
2. Place the fuse puller on the fuse and pull it out. (The fuse puller is stored in the fuse box inside the cab.)

3. If the fuse appears as shown in the right hand side of the diagram at left, the fuse is blown. Replace with a spare fuse. (Spare fuses are stored in the fuse box inside the cab.)

WARNING

- Use fuses of the same rating for replacement. Do not use any other fuses than those designated.
- Using fuses other than those specified could result in fire or damage to the equipment.
- If the new fuses blow right away, contact the nearest Isuzu Dealer.

Replacing Relays

Before replacing relays, remove the cover.



ADVICE

- It is not necessary to open or close the cover unless trouble is found.
- The relay box structure makes it difficult for water to enter. If you should spill water or a beverage on the cover, however, wipe it off before opening the cover.
- The area around the cover will get warm when the vehicle is being driven, but this is not abnormal.

Replacing Slow-blow Fuses

When the headlights and other devices in the electrical system do not work, but there is no problem with the fuses, check the slow-blow fuse.

Replace the slow-blow fuse when it blows. Please contact the nearest Isuzu Dealer. Slow-blow fuses protect the electrical circuits, and they are installed so that they can be quickly replaced if there is a malfunction.



WARNING

- Use an Isuzu genuine part when replacing the slow-blow fuse.
- Do not use any material other than designated slow-blow fuses. Using other materials could cause a serious malfunction or fire.
- If the new slow-blow fuses blow right away, contact the nearest Isuzu Dealer.



NOTE

- If an overload exists in the circuit from the battery, the slow-blow fuse will melt before the wiring harness is damaged.

Fuse and Relay Location

Fuse locations: cab interior

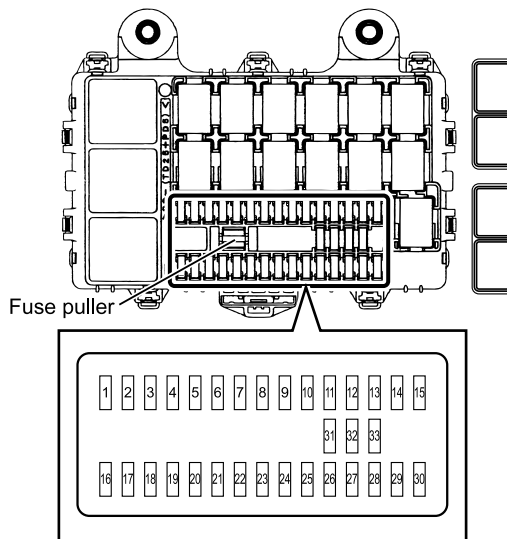

No.	Description	Rating	No.	Description	Rating
1	ELEC PTO (BATT)	20A	18	IGNITION1	15A
2	RR P/WINDOW	20A	19	SRS	10A
3	ROOM LAMP, AUDIO	15A	20	ECM	10A
4	DOOR LOCK	15A	21	METER	10A
5	FOG LAMP	10A	22	LAMPS (BATT)	10A
6	P/WINDOW	20A	23	AUDIO, ACC	15A
7	ABS	10A	24	MIRROR	15A
8	WIPER	15A	25	HORN	15A
9	H/LAMP LO (LH)	10A	26	TURN, HAZARD	15A
10	ECU (BATT)	10A	27	TAIL LAMPS	10A
11	H/LAMP LO (RH)	10A	28	ILLUMINATIONS	10A
12	STOP LAMP	10A	29	CORNERING LAMPS, RR FOG LAMP	10A
13	IGNITION2	15A	30	BLOWER MOTOR	20A
14	H/LAMP HI (LH)	10A	31	SPARE	—
15	H/LAMP HI (RH)	10A	32	SPARE	—
16	ELEC PTO (KEY ST)	10A	33	SPARE	—
17	STARTER	10A			

Relay locations: cab interior

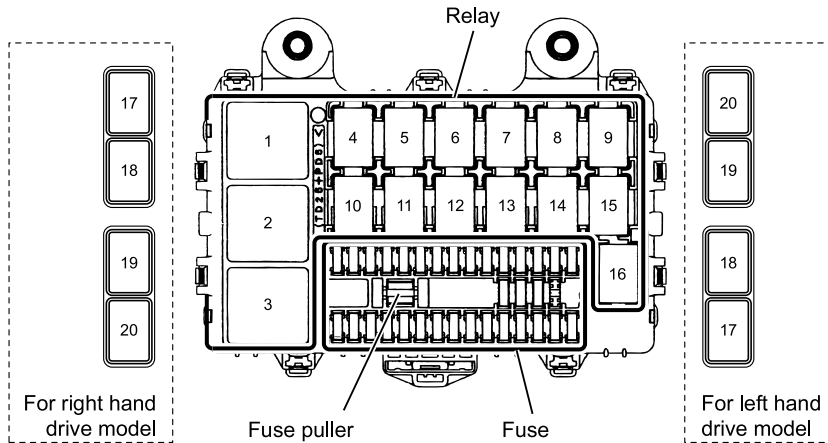

No.	Description
1	STOP LAMP
2	BLOWER MOTOR
3	KEY ON
4	DOOR LOCK (LOCK)
5	REAR FOG LAMP
6	WIPER MAIN
7	HORN
8	WIPER (HIGH/LOW)
9	FOG LAMP
10	PTO MAIN
11	DOOR LOCK (UNLOCK)

No.	Description
12	POWER WINDOW
13	HEAD LAMP (LOW)
14	4WD
15	HEAD LAMP (HIGH)
16	TAIL LAMP
17	PTO SOLENOID, M/T
18	PTO CUT
19	CHARGE (ENGINE RUN) TRANSFER IGNITION1
20	POWER WINDOW (REAR)

Fuse and relay locations: cab exterior

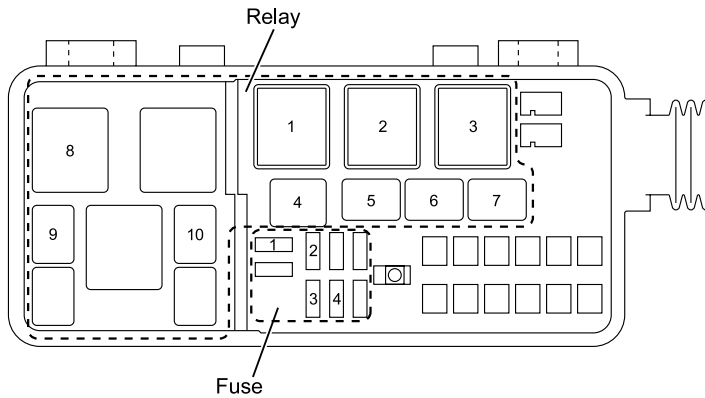

No.	Relay name
1	STARTER
2	ECM
3	GLOW PLUG
4	A/C COMPRESSOR
5	CONDENSER FAN
6	STARTER CUTOFF
7	MARKER LAMP
8	GEARSHIFTER
9	4WD (4HK1 ENGINE MODEL)
10	TRANSFER GEAR CONTROL

No.	Fuse name	Rating
1	MARKER LAMP	10A
2	ECM MAIN	10A
3	BATTERY	10A
4	A/C	10A

When Your Vehicle is Involved in an Accident

Stay calm and take the following steps:

1. Avoid a chain of accidents
Operate the hazard warning flasher, pull the vehicle immediately over to a safe place that doesn't impede traffic (shoulder, verge) and stop the engine.
2. Aid the injured
Render whatever first aid is possible to injured people until a doctor or ambulance arrives. In particular, do not move people with head injuries. If there is a danger of a series of accidents, move them to a safe place.
3. Contact the police
Contact the police, give them the information on the location of the accident, the conditions, injured people and the extent of their injuries, and then receive instructions.
4. Confirm information from other parties (name, address and telephone number) and the conditions of the accident.
5. If necessary, contact the insurance company or the dealer you purchased the vehicle from.



ADVICE

- Make sure to notify the police and consult a doctor even for small accidents and light injuries. When receiving a blow to the head in particular, it is possible for symptoms to develop later even if there are no external wounds.

When Driving on Bad Roads



Pressing the accelerator pedal will dig the vehicle deeper into the mud and make it harder to extricate.

Either put stones, tree branches or blankets under the tyres to gain traction, or repeatedly drive forward and in reverse and use the vehicle's momentum to extricate it.

When Towing

To move a disabled vehicle, it is best to rely on someone in the wrecker or tow truck business. If that is not possible, follow these procedures.

When towing, use appropriate equipment and comply with local legal requirements. Do not try to start the engine by towing or pushing the vehicle.

WARNING

- Be sure to chock the wheels when disconnecting the propeller shaft. The vehicle could start to move and cause a serious accident.

CAUTION

- For a manual transmission model, place the gearshift lever in the "N" position, and tow for a maximum distance of 10 km (6.2 miles) at speeds less than 40 km/h (25 MPH). Other than the above, disconnect the propeller shaft when towing to avoid damage to the transmission.
- For AMT vehicles, place the gearshift lever in the "N" position and make sure the shift indicator displays "N". Tow for a maximum distance of 10 km (6.2 miles) at speeds less than 40 km/h (25 MPH).
When the shift indicator does not indicate "N", or in situations other than the above, disconnect the propeller shaft when towing to avoid damage to the transmission.
- Whenever possible, tow a vehicle with the engine started.
If the engine is not started:
 - The brakes will not be as effective;
 - The steering wheel will be hard to turn;
 - The steering wheel could lock, making it impossible to turn. This is extremely dangerous (particularly when the ignition key is removed).

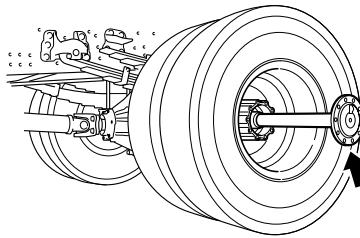
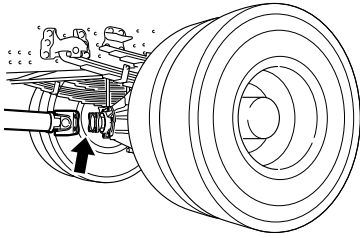

When it is possible to operate the steering wheel, the vehicle can be towed with all wheels on the ground.

However, the power steering will not be able to provide any power assist when the engine cannot be started.

If the transmission is damaged, disconnect the propeller shaft at the rear axle flange and secure it to the frame.

If the rear axle fails or rear axle failure is suspected, remove the axle shaft and plug up the opening of the hub to prevent differential gear oil from leaking, or to prevent dirt or foreign objects from entering the axle.

Front

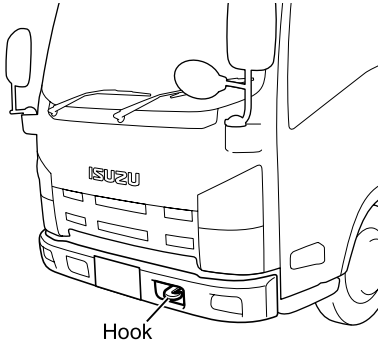

Rear

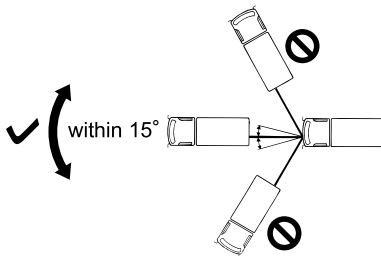
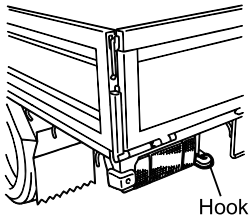

1. If the vehicle is towing or being towed, firmly attach a rope to the front or rear towing hook on the same side.
2. During towing, carefully watch the stop lights of the towing vehicle in order to prevent the rope from becoming slack. Ensure that there is no strong shock or lateral force applied to the vehicle.

**CAUTION**

- Do not tow a vehicle at an angle of greater than 15°. This could exert too much stress on the vehicle and damage it.
- Attach a rope to the towing hook only. Attaching a rope to other part of the vehicle could damage it.
- Make sure there are no people near the towing rope and hook before towing a vehicle. If the rope snaps, people nearby could be injured.
- The towing hook is for use to tow a vehicle with about the same weight as the towing vehicle on good roads.
- When coming to channels or muddy areas, unload the vehicle. Do not use the towing hook to tow, but tow with a rope attached to the axle.
- For vehicles with hill-start-aid (HSA), cancel the HSA by pressing the HSA OFF switch.

HSA OFF Switch → Refer to page 4-98

**ADVICE**

- In the case of a four wheel drive (4WD) model, set the 4WD switch to "OFF" before towing. Failure to do so could cause the brakes to activate during towing.

[Contact a tow truck at these times]

- When the vehicle will descend long hills. (The brakes could overheat and become ineffective.)
- When the transmission or differential fails.
- When the vehicle breaks down on a highway.

4WD Switch → Refer to page 4-126



• Main Data and Specifications

Main Data and Specifications

Engine

4JJ1 Engine Model

Specifications		
Water-cooled, overhead camshaft, direct injection engine with an inter-cooled turbocharger		
Compression ratio	(to 1)	17.5
Displacement	cc (cu. in)	2,999 (183.0)
Firing order		1-3-4-2
Fuel injection timing	(static) degree	0°
Valve clearance	mm (in)	Both intake and exhaust valves: 0.15 (0.006) in cold engine
Idling speed	r/min	575 - 625
Fan belt tension	mm (in)/Hz	New belt: 4 - 6 (0.16 - 0.24)/212 - 236
		Used belt: 6 - 8 (0.24 - 0.31)/181 - 195
Oil filter		Replaceable element type
Engine oil capacity [Reference value]	litres (US gal./Imp gal.)	10.0 (2.64/2.20)
Coolant capacity [Reference value]	litres (US gal./Imp gal.)	10.0 (2.64/2.20)
Preheating system		Glow plugs
Turbocharger model		RHF5V (IHI)

4HK1 Engine Model

Specifications	
Water-cooled, overhead camshaft, direct injection engine with an inter-cooled turbocharger	
Compression ratio (to 1)	17.5
Displacement cc (cu. in)	5,193 (317)
Firing order	1-3-4-2
Fuel injection timing (static) degree	0°
Valve clearance mm (in)	Both intake and exhaust valves: 0.4 (0.016) in cold engine
Idling speed r/min	M/T 550 - 600, SA 625 - 675
Fan belt tension mm (in)/Hz	50A alternator New belt: 5 - 7 (0.20 - 0.28)/208 - 232 Used belt: 6 - 8 (0.24 - 0.31)/178 - 190
Oil filter	Cartridge (spin on) type
Engine oil capacity [Reference value] litres (US gal./Imp gal.)	2WD model: 13.0 (3.43/2.86) including capacity of 3.0 (0.79/0.66) in filter 4WD model: 12.5 (3.30/2.75) including capacity of 3.0 (0.79/0.66) in filter
Coolant capacity [Reference value] litres (US gal./Imp gal.)	18.0 (4.76/3.96)
Preheating system	Glow plugs
Turbocharger model	G25 (Honeywell)

Transmission

MYY5T Model (including AMT)

Specifications		
Five-speed transmission (overdrive gear for 5th), synchromesh for 2nd to 5th		
Gear ratio (to 1)	1st	5.315
	2nd	3.053
	3rd	1.655
	4th	1.000
	5th	0.721
	Reverse	5.068
Transmission oil capacity [Reference value] litres (US gal./Imp gal.)	Model without PTO: 2.8 (0.74/0.62) Model with PTO: 3.1 (0.82/0.68)	
AMT clutch oil capacity [Reference value] litres (US gal./Imp gal.)	6.24 (1.64/1.37)	

MY6S Model (including AMT)

Specifications		
Six-speed transmission (overdrive gear for 6th), synchromesh for 2nd to 6th		
Gear ratio (to 1)	1st	5.979
	2nd	3.434
	3rd	1.862
	4th	1.297
	5th	1.000
	6th	0.759
	Reverse	5.701
Transmission oil capacity [Reference value] litres (US gal./Imp gal.)	Model without PTO: 3.5 (0.92/0.77) Model with PTO: 3.8 (1.00/0.84)	
AMT clutch oil capacity [Reference value] litres (US gal./Imp gal.)	6.24 (1.64/1.37)	

MZZ6F Model (including AMT)

Specifications		
Six-speed transmission (overdrive gear for 6th), synchromesh for 2nd to 6th		
Gear ratio (to 1)	1st	6.369
	2nd	3.767
	3rd	1.966
	4th	1.355
	5th	1.000
	6th	0.782
	Reverse	6.369
Transmission oil capacity [Reference value] litres (US gal./Imp gal.)	Model without PTO: 4.4 (1.16/0.97) Model with PTO: 5.3 (1.40/1.17)	
AMT clutch oil capacity [Reference value] litres (US gal./Imp gal.)	6.14 (1.62/1.35)	

MZZ6U Model (including AMT)

Specifications		
Six-speed transmission (overdrive gear for 6th), synchromesh for 2nd to 6th		
Gear ratio (to 1)	1st	6.369
	2nd	3.767
	3rd	2.234
	4th	1.442
	5th	1.000
	6th	0.782
	Reverse	6.369
Transmission oil capacity [Reference value] litres (US gal./Imp gal.)	Model without PTO: 4.4 (1.16/0.97) Model with PTO: 5.3 (1.40/1.17)	
AMT clutch oil capacity [Reference value] litres (US gal./Imp gal.)	6.14 (1.62/1.35)	

• Main Data and Specifications

Main Data and Specifications

Engine

4JJ1 Engine Model

Specifications		
Water-cooled, overhead camshaft, direct injection engine with an inter-cooled turbocharger		
Compression ratio	(to 1)	17.5
Displacement	cc (cu. in)	2,999 (183.0)
Firing order		1-3-4-2
Fuel injection timing	(static) degree	0°
Valve clearance	mm (in)	Both intake and exhaust valves: 0.15 (0.006) in cold engine
Idling speed	r/min	575 - 625
Fan belt tension	mm (in)/Hz	New belt: 4 - 6 (0.16 - 0.24)/212 - 236
		Used belt: 6 - 8 (0.24 - 0.31)/181 - 195
Oil filter		Replaceable element type
Engine oil capacity [Reference value]	litres (US gal./Imp gal.)	10.0 (2.64/2.20)
Coolant capacity [Reference value]	litres (US gal./Imp gal.)	10.0 (2.64/2.20)
Preheating system		Glow plugs
Turbocharger model		RHF5V (IHI)

4HK1 Engine Model

Specifications	
Water-cooled, overhead camshaft, direct injection engine with an inter-cooled turbocharger	
Compression ratio (to 1)	17.5
Displacement cc (cu. in)	5,193 (317)
Firing order	1-3-4-2
Fuel injection timing (static) degree	0°
Valve clearance mm (in)	Both intake and exhaust valves: 0.4 (0.016) in cold engine
Idling speed r/min	M/T 550 - 600, SA 625 - 675
Fan belt tension mm (in)/Hz	50A alternator New belt: 5 - 7 (0.20 - 0.28)/208 - 232 Used belt: 6 - 8 (0.24 - 0.31)/178 - 190
Oil filter	Cartridge (spin on) type
Engine oil capacity [Reference value] litres (US gal./Imp gal.)	2WD model: 13.0 (3.43/2.86) including capacity of 3.0 (0.79/0.66) in filter 4WD model: 12.5 (3.30/2.75) including capacity of 3.0 (0.79/0.66) in filter
Coolant capacity [Reference value] litres (US gal./Imp gal.)	18.0 (4.76/3.96)
Preheating system	Glow plugs
Turbocharger model	G25 (Honeywell)

Transmission

MYY5T Model (including AMT)

Specifications		
Five-speed transmission (overdrive gear for 5th), synchromesh for 2nd to 5th		
Gear ratio (to 1)	1st	5.315
	2nd	3.053
	3rd	1.655
	4th	1.000
	5th	0.721
	Reverse	5.068
Transmission oil capacity [Reference value] litres (US gal./Imp gal.)	Model without PTO: 2.8 (0.74/0.62) Model with PTO: 3.1 (0.82/0.68)	
AMT clutch oil capacity [Reference value] litres (US gal./Imp gal.)	6.24 (1.64/1.37)	

MY6S Model (including AMT)

Specifications		
Six-speed transmission (overdrive gear for 6th), synchromesh for 2nd to 6th		
Gear ratio (to 1)	1st	5.979
	2nd	3.434
	3rd	1.862
	4th	1.297
	5th	1.000
	6th	0.759
	Reverse	5.701
Transmission oil capacity [Reference value] litres (US gal./Imp gal.)	Model without PTO: 3.5 (0.92/0.77) Model with PTO: 3.8 (1.00/0.84)	
AMT clutch oil capacity [Reference value] litres (US gal./Imp gal.)	6.24 (1.64/1.37)	

MZZ6F Model (including AMT)

Specifications		
Six-speed transmission (overdrive gear for 6th), synchromesh for 2nd to 6th		
Gear ratio (to 1)	1st	6.369
	2nd	3.767
	3rd	1.966
	4th	1.355
	5th	1.000
	6th	0.782
	Reverse	6.369
Transmission oil capacity [Reference value] litres (US gal./Imp gal.)	Model without PTO: 4.4 (1.16/0.97) Model with PTO: 5.3 (1.40/1.17)	
AMT clutch oil capacity [Reference value] litres (US gal./Imp gal.)	6.14 (1.62/1.35)	

MZZ6U Model (including AMT)

Specifications		
Six-speed transmission (overdrive gear for 6th), synchromesh for 2nd to 6th		
Gear ratio (to 1)	1st	6.369
	2nd	3.767
	3rd	2.234
	4th	1.442
	5th	1.000
	6th	0.782
	Reverse	6.369
Transmission oil capacity [Reference value] litres (US gal./Imp gal.)	Model without PTO: 4.4 (1.16/0.97) Model with PTO: 5.3 (1.40/1.17)	
AMT clutch oil capacity [Reference value] litres (US gal./Imp gal.)	6.14 (1.62/1.35)	

A

Air Cleaner	7-47
Air Conditioning Filters <input type="checkbox"/>	7-144
Air Outlets	5-2
AMT Clutch Oil	7-109
AMT	2-41
Antenna	5-31
Anti-lock Brake System (ABS) <input type="checkbox"/>	4-115
Anti-Slip Regulator (ASR) <input type="checkbox"/>	4-120
Ashtray <input type="checkbox"/>	5-23
Automatic Air Conditioner <input type="checkbox"/>	5-12

B

Back Panel Tray (Storage Receptacle) <input type="checkbox"/>	5-28
Before Driving	2-16
Brake Hoses and Pipes	7-74
Brakes	7-62

C

Card Holder	5-25
Carrying Children	2-28
Cautions for Driving in Cold Regions	6-17
Cautions for Driving in Hot Regions	6-16
Cautions for Parking	6-15
Centre Console Box <input type="checkbox"/>	5-26
Changing Tyres	7-88
Chassis and Engine Numbers	1-2
Checking Components that Showed Abnormalities during Previous Operation	7-17
Cigarette Lighter	5-22
Clutch <input type="checkbox"/>	7-100
Coat Hook <input type="checkbox"/>	5-29
Combination Light Control Switch	4-64
Cruise Control <input type="checkbox"/>	4-108
Cup Holder <input type="checkbox"/>	5-27

D

Daily Checks (Preoperational Checks)	7-16
Diesel Particulate Defuser (DPD)	2-60, 4-154, 7-58
Disc Brakes <input type="checkbox"/>	7-73
Discarded Parts, Oils and Other Liquids	7-6
Driving	2-30
Driving Safely and with Confidence	6-2
Drum Brakes <input type="checkbox"/>	7-75

E

Electronic Braking force Distribution (EBD) <input type="checkbox"/>	4-119
Engine Conditions	7-20
Engine Coolant	7-32
Engine Coolant Temperature Gauge	4-12
Engine Oil	7-22
Exhaust Brake Switch	4-69
Exterior Maintenance	7-148
Exterior (PICTORIAL INDEX)	0-12

F

Fan Belt	7-44
Four Wheel Drive (4WD) Model <input type="checkbox"/>	2-44, 4-124
Front Axle Differential Gear Oil <input type="checkbox"/>	7-114
Front Fog Light Switch <input type="checkbox"/>	4-67
Fuel Filter	7-51
Fuel Gauge	4-13
Fuel Tank Filler Cap	3-13
Fully Adjustable Steering	3-21

G

Gear Shift Lever	4-78
Glove Compartment <input type="checkbox"/>	5-26
Greasing Chassis Components	7-124

H

Handling the Battery	7-138
Handling the Jack	7-128
Hazard Warning Flasher Switch	4-68
Headlight Leveling Switch <input type="checkbox"/>	4-66
Headlights and Turn Signal Lights	7-137
Heater/Manual Air Conditioner <input type="checkbox"/>	5-5
Hill-Start-Aid (HSA) <input type="checkbox"/>	4-98
Hook	5-29
Horn Button	4-73
Hour Meter <input type="checkbox"/>	4-14
How to Read the Instruments (Instruments Layout)	4-8
Hub Bearing Grease	7-123
Hydraulic Brake Booster (HBB) <input type="checkbox"/>	4-113

I

Idling Control Knob <input type="checkbox"/>	4-62
Inspection and Maintenance	7-159
Inspection Hatches <input type="checkbox"/>	7-9
Interior Lights	5-20
Interior Maintenance	7-151
Interior (PICTORIAL INDEX)	0-11
Isuzu Genuine Oils and Grease	7-6

K

Key	3-2
Key with Immobilizer Transponder Chip <input type="checkbox"/>	3-3
Keyless Entry System <input type="checkbox"/>	3-4

M

Main Data and Specifications	9-2
Mirror Heater Switch <input type="checkbox"/>	4-74
Mirrors	3-22
Model with AMT <input type="checkbox"/>	4-81
Model with Speed Limit Device <input type="checkbox"/>	2-63
Multi-Information Display (MID) <input type="checkbox"/>	4-17

O

On the Road	6-3
Opening and Closing Doors	3-7
Overhead Tray <input type="checkbox"/>	5-27

P

Parking Brake	7-72
Parking Brake Lever	4-77
Pedals	4-76
Power Steering Fluid	7-120
Power Take-OFF (PTO) <input type="checkbox"/>	4-128
Power Windows <input type="checkbox"/>	3-10
Precautions for Checking and Adjustments	7-4
Preventing Breakdowns	2-44

R

Rear Axle Differential Gear Oil	7-112
Rear Fog Light Switch <input type="checkbox"/>	4-68
Refrigerant <input type="checkbox"/>	7-146
Remote Control Mirror Switch <input type="checkbox"/>	4-73
Replacing the Fuses and Relays	8-37

S

Seat Belt with Pretensioner and SRS Airbag System <input type="checkbox"/>	2-64, 4-143
Seat Belts	3-23
Seats	3-17
Small Article Storage Pocket <input type="checkbox"/>	5-25
Spare Tyre <input type="checkbox"/>	7-98
Speedometer	4-9
Starter Switch	4-60
Starting the Engine	4-4
Staying Safe	2-53
Stopping and Parking	2-47
Stopping the Engine	4-6
Sun Visor	5-21

T

Tachometer	4-11
Tilting the Cab <input type="checkbox"/>	7-12
Tyre Rotation	7-86
Tool Box <input type="checkbox"/>	3-16
Tools	7-7
Transfer Gear Case Oil <input type="checkbox"/>	7-117
Transmission Oil	7-105
Troubleshooting	8-2

U

Using Tyre Chains	6-22
-------------------	------

V

Vehicle Data Collection	2-67
Ventilator <input type="checkbox"/>	5-3

W

Warm-Up Switch <input type="checkbox"/>	4-63
Warning and Indicator Lights	4-34
Warning and Indicator Lights Layout	4-15
Warning Buzzer	4-58
Warning/Caution Labels in Your Vehicle	0-21
Warning/Indicator Light Index	0-16
Wheels and Tyres	7-77
When Driving on Bad Roads	8-42
When the Battery Goes Flat	8-12
When the Brakes Do not Work	8-11
When the Bulb Does not Come On	8-24
When the Engine Overheats	8-22
When the Engine Stalls and Cannot be Restarted	8-10
When the Engine Stops While Driving	8-9
When the Fuel Runs Out	8-14
When the Meter Shows an Abnormality	8-23
When the Tyre Goes Flat	8-8
When the Vehicle Breaks Down during Driving	8-7
When the Warning Light Comes On	8-16
When to Visit Your Isuzu Dealer	2-58
When Towing	8-43
When Your Vehicle is Involved in an Accident	8-42
Windshield Washer Fluid	7-133
Windshield Wiper and Windshield Washer Switch	4-71
Windshield Wiper Blades	7-134

MEMO

