

Kubota



KUBOTA ZERO TAIL SWING COMPACT EXCAVATOR

U

U17-3

Kubota's U17-3 zero-tail swing compact excavator gives you the performance and efficiency you need in tight spaces.



*This information is sourced from overseas and may not necessarily apply locally. It is essential that you confirm specifications and other information with your local Kubota dealer.

When space is at a premium, the U17-3 delivers the maneuverability, power, performance and versatility that get the job done.

When you have to take on a tough job in a tight space, look no further than the versatile U17-3. This compact excavator delivers the power you need, the control you want, and the smooth performance you demand. Plus, Kubota has improved the pump capacity, extended the dozer arm, and loaded it with a host of other upgrades that will help you get the job done more efficiently and more productively.

**KUBOTA ZERO TAIL SWING
COMPACT EXCAVATOR**

U17-3

More powerful engine

We've upgraded the engine from 13HP to 17HP, so the U17-3 delivers more of the power and dependability your work requires. In addition to its superior horsepower and performance, it also offers low noise and vibration levels, exceptional fuel efficiency, and complies with the EPA's 2008 Tier IV emissions regulations.

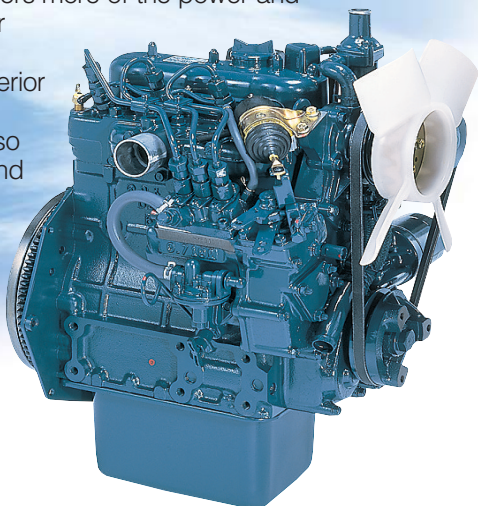

Improved pump capacity

We've increased the hydraulic pump capacity to 45 l/min, giving you the boost of versatility you need to take on a wide variety of jobs.

Digital panel

Informative, interactive and functional, Kubota's Intelligent Control System LCD panel accurately displays timely diagnostic readings and routine maintenance alerts. You'll be kept informed of your current working conditions, engine RPM, temperature and oil levels. It even emits an alert when the tank is nearly full during refueling. These features help reduce downtime and costly repair fees.



Extended dozer arm

Kubota has extended the dozer arm to optimize the clearance between the dozer and the bucket—this makes collecting soil and rocks close to the machine simple and more efficient. And, the extended length of the dozer arm also helps prevent soil or rocks from getting caught between the dozer and the crawler.



ZERO-TAIL SWING

Zero-tail swing means you'll never again worry about what is to the side or behind you while you work. No matter how far you turn, the tail always remains within the width of the tracks. Zero-tail swing also ensures excellent balance, stability and faster operation, making the U17-3 ideal for jobs in congested urban areas.

Double-flanged track roller & short-pitched rubber crawler

Like many higher-end excavators, the U17-3 features double-flanged track rollers and short-pitched rubber crawlers for improved undercarriage durability. The double-flanged track rollers help improve travel stability and performance, and the short-pitched rubber crawlers help minimize vibration during travel for improved operator comfort. With the U17-3, a day on the job always goes smoothly.



Variable track width

The U17-3 features a hydraulic track gauge that can be adjusted to between 990 mm and 1,240 mm. With the touch of a single lever, you can reduce the track gauge to navigate narrow spaces or increase it to improve functionality.





From outstanding lifting capacity to incredible operator comfort, the U17-3 has the features to take your performance higher.

Strong bucket breakout force

The U17-3 has the power you need for heavy loads and tough excavating jobs, a breakout force of 1550 kg, with the dedicated bucket and quick coupler.

Strong lifting capacity

Excellent lifting capacity for digging, lifting, and loading is provided by a powerful and responsive front working group. Even when working to the side, using hydraulic attachments, or lifting heavy objects, the U17-3 has excellent stability, thanks to its innovative counter balancing technology, long tumbler distance, low center of gravity and smooth operation.

Working range

The U17-3's excellent reach and digging depth ensure that each digging job is performed with maximum efficiency and speed.

Improved travel motor

Kubota has upgraded the U17-3's travel motor, resulting in a 10% traction increase, when operating in low speed.



Swing bracket pin bushings

For increased durability and longer life, Kubota has included bushings throughout the U17-3's pivot points on the swing bracket.

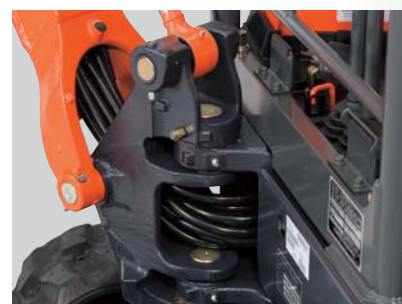

High-back suspension seat

The U17-3's deluxe high-back seat increases productivity by providing optimum comfort for operators of all sizes.

2-speed travel switch

By placing the 2-speed travel switch on the dozer lever, dozing operations have become faster and easier. The new location also frees up space on the floor for improved operator comfort.



12V electric power socket



Wider foot area

More spacious than many conventional tail-swing excavators, the U17-3's wider foot area enhances operator comfort. The result is less operator fatigue and greater job efficiency.



Two-pattern Selection System (TPSS)

A quick flip of a lever lets you switch operating patterns from ISO to SAE or vice versa.



Boom cylinder

Located above the boom, the boom cylinder remains safe from damage during breaker or dumping operations. The cylinder design features a larger diameter rod and increased hydraulic pressure for greater lifting power and optimum front attachment speeds.

Smooth operation

Smooth operation across a wide range of jobs is assured, thanks to the U17-3's advanced variable displacement pumps and Hydraulic Matching System.

Auxiliary hydraulic system

The U17-3's auxiliary hydraulic system accommodates a variety of attachments, such as breakers and augers. Standard equipment includes port pipes on the arm, bi-directional auxiliary hydraulic controls, and a control valve. The auxiliary hydraulic connections are located within easy reach and incorporate short hoses that are less likely to become tangled or damaged.

ROPS/FOPS canopy

The ROPS and the FOPS canopy meet the applicable ISO, SAE and OSHA standards, providing complete protection from accidental rollovers and falling objects, and ensuring an extra level of safety and security on the job.





If it's easy maintenance you're looking for, take a look at the U17-3.

Protected motor hoses

For added protection, Kubota has enclosed the travel motor hoses within the track frame, resulting in reduced repair costs and increased durability.



Protected front hoses

For greater protection, the U17-3's front hoses are routed within the arm. This design also improves operator visibility, increases hose service life, and lowers repair costs.

Hydraulics maintenance

The under-deck hydraulics can be accessed quickly and easily for routine maintenance. There are no bolts to unscrew—just lift the rubber mat and open the floor plate.



UNDER THE COVER

General maintenance

Wide-opening covers provide easy access to the engine oil gauge, coolant reserve tank and dual element air cleaner. It's also easy to access the fuel filter and water separator, battery, radiator and oil cooler. Two-piece hose connections for the dozer and boom cylinders simplify hose replacement, reduce downtime, and virtually eliminate the need to enter the machine for maintenance.



LEFT SIDE HOOD



REAR HOOD

Safe, controlled starts

When the safety control lever is moved upward, the console moves with it, providing more room for entry and exit. To prevent unexpected machine movement during entry or exit, the pilot and travel controls are then disabled. This is the only time that the engine will crank over.

Straight travel

Kubota's Hydraulic Matching System keeps the U17-3 traveling in a straight line while operating the boom, assisting in loading and off-loading.

U17-3 OPTIONS

Quick coupler



Buckets

WORKING RANGE

Model		U 17-3		
A	Max. digging height	mm	3540	
B	Max. dumping height	mm	2440	
C	Max. digging depth	mm	2310	
D	Max. vertical digging depth	mm	1910	
E	Max. digging radius at ground	mm	3840	
F	Max. digging radius	mm	3900	
G	Min. turning radius	W/o swing	mm	1440
		With swing	mm	1215
H	Min. tail turning radius	mm	620	

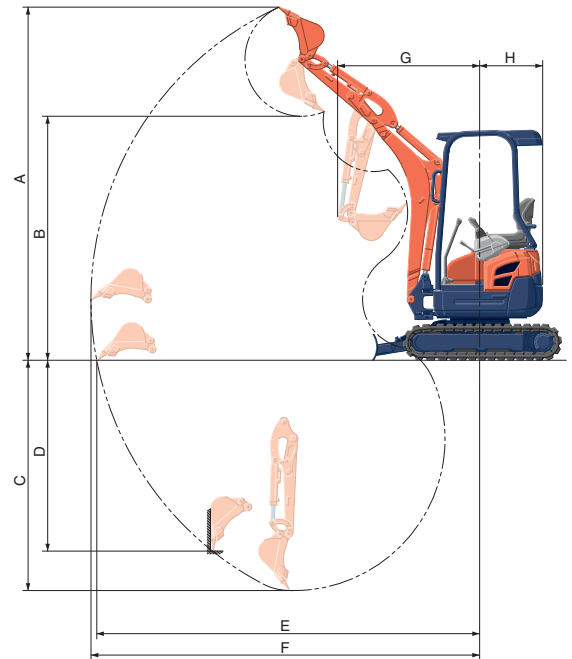

LIFTING CAPACITY

LIFT POINT HEIGHT (mm)	LIFTING CAPACITY OVER-FRONT BLADE DOWN unit=1000 KGS				LIFTING CAPACITY OVER-SIDE unit=1000 KGS		
	LIFT POINT RADIUS (KGS)				LIFT POINT RADIUS (KGS)		
	2	2.5	3		2	2.5	3
GL	2	0.28	0.32	-	0.28	0.24	-
	1.5	0.40	0.36	0.32	0.33	0.24	0.18
	1	0.55	0.41	0.33	0.31	0.23	0.17
	0	0.58	0.43	0.32	0.29	0.21	0.17

Machine with ROPS canopy and rubber crawler, without bucket

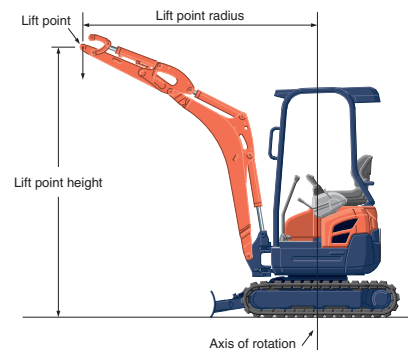

SPECIFICATIONS

Model		U17-3		
Type of ROPS / FOPS		Canopy		
Type of tracks		Rubber		
Engine	Model		Kubota D902-E3	
	Output (SAEJ 1995 gross)	HP (kW)/rpm	17.0 (12.7) / 2300	
	Output (SAEJ 1349 net)	HP (kW)/rpm	15.2 (11.3) / 2300	
	Displacement	cc	898	
Dimensions	Overall length	mm	3545	
	Overall height	mm	340	
	Overall width	mm	990 / 1240	
	Min. ground clearance	mm	150	
Hydraulic system	Pump capacity	ℓ /min	17.3 × 2 / 10.4 × 1	
	Auxiliary hydraulic flow	ℓ /min	27.7	
	Max. breakout force	Bucket / Arm	kgf	1550 / 870
Drive system	Travel speed	Low / High	km/h	2.1 / 4.1
	Max. drawbar pull		kgf	2207
	Tumbler distance		mm	1230
	Crawler length		mm	1585
	Shoe width		mm	230
	Ground contact pressure		kgf/cm ²	0.27
Swing system	Unit swing speed		rpm	9.1
	Boom swing angle	Left / Right	degree	65 / 58
Blade	Dimensions	Width	mm	1240 / 990
		Height	mm	260
	Max. lift above ground		mm	280
	Max. drop below ground		mm	190
Hydraulic oil (reservoir / system)		ℓ	13 / 23	
Fuel reservoir		ℓ	19	
Operating weight (Including operator's weight 80 kg.)		kgs	1730	

The company reserves the right to change specifications without notice. This brochure is for descriptive purposes only.
Please contact your local Kubota dealer for warranty information.
For your safety, Kubota strongly recommends the use of a Rollover Protective Structure (ROPS) and seat belt for almost all applications.

DIMENSIONS

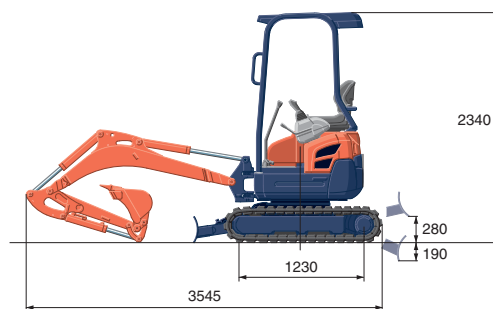
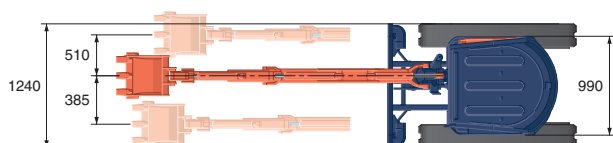

Unit: mm

©2008 Kubota Corporation



KUBOTA Tractor Australia Pty Ltd

100 Keilor Park Drive, Tullamarine Vic., 3043
Freecall: 1800 334 653
Email: sales@kubota.com.au

Web Site: <http://www.kubota.com.au>