



**GENERATOR AND  
LIGHTING TOWER**

# **Operation Manual**



---

---

# CONTENTS

1. COMPANY OVERVIEW .....	2
2. INTRODUCTION .....	3
3. IDENTIFICATION .....	4
4. SPECIFICATIONS.....	5
5. GENERAL DESCRIPTION.....	6
6. SAFETY PRECAUTIONS.....	8
7. FIRST AID FOR ELECTRICAL INJURIES .....	11
8. OPERATING INSTRUCTIONS .....	13
8.1 CONTROL IDENTIFICATION.....	14
8.2 TYPICAL DECALS.....	15
8.3 JOB SAFETY ANALYSIS (JSA).....	18
8.4 GENERATOR AND LIGHTING TOWER OPERATION .....	23
8.5 FAULT DIAGNOSIS.....	36
A. REPORTING SAFETY DEFECTS .....	37
B. PRE-START CHECKS .....	38

Complete this section on receipt of your new Lighting Tower.

In Service Date		Owner Name	
Allight Build		Unit No	
Engine Type		Serial No	
Alternator Type		Serial No	

The Allight machine you have purchased is a product of Allight's long years of experience with Mobile Lighting, Dewatering and Power Generation markets. Allight takes pride in the superior durability and operating economy of its products.

In order to receive maximum benefit from your product, please read this manual carefully and follow the operating instructions.

All information, illustrations and specifications contained in this manual are correct at the time of publication.

Allight reserves the right to make changes in this manual at any time without prior notice and accepts no responsibility for the accuracy or otherwise of the information contained within. The design of equipment and this publication are protected by copyright. © 2007 Allight Pty Ltd.

---

---

# 1. ALLIGHT CORPORATE PROFILE

**Power Your Performance** with Allight's range of mobile lighting towers, pumps, generators and diesel engines.

**OUR VISION** - To be the leader in comprehensive and innovative equipment solutions with a reputation for service excellence.

**OUR COMPANY** - From mine sites to hospitals, rescue missions to rock concerts, out at sea or in the countryside, in construction projects and road works, since 1988 we have been supplying complete equipment solutions across the globe. With sales offices located in Australia, Indonesia and the USA, we also have a growing network of authorised Allight Dealers to support our products around the world.

**OUR PRODUCTS** - The extensive range of Allight engineered and manufactured equipment includes Allight® Mobile Lighting Towers, Allight® Mobile Generators and Allight® Pumps.

We are also proud to be recognised as distributors for some of the world's leading manufacturers of industrial equipment, including FG Wilson Diesel and Gas Generators (Australia and the Pacific Islands), Perkins and Perkins Sabre Diesel Engines (Australia and Papua New Guinea), Geminiani Power Packs (Asia-Pacific), Godwin Pumps (Australia) and Loadtec Digital Solution Load Banks (Australia).

**OUR PRODUCT SUPPORT** - To ensure that your Allight products always Power Your Performance, our product support facilities include Service Technicians, Parts Support and Technical Help – available 7 days a week from your local Allight branch or authorised Allight Dealer.

**OUR ENGINEERING & MANUFACTURING** - Based in Perth, Western Australia, we have engineering and product design facilities, which ensure all manufactured products, comply with strict ISO quality standards. Extensive research and testing is undertaken for all Allight manufactured equipment, ensuring that they meet both or exceed customer and industry requirements.

**OUR PEOPLE** - We aim to be the employer of choice in our industries, in a workplace which provides safety, security, challenge and opportunities. We believe that an investment in the training and development of our people is an investment in the future success of Allight and support promotion of internal career paths in any of our offices located in Australia and across the world.

**OUR HEALTH AND SAFETY COMMITMENT** - Guided by an internally developed Occupational Health and Safety program based on best practices, we are passionate about conducting business in a safe manner. Our philosophy is simple 'we take no risks with our people or our customers'.

**OUR ENVIRONMENTAL COMMITMENT** - We have a strong environmental policy and are committed to protecting and preserving the environment by using quality environmentally friendly products and pursuing strategies that address the growing number of ecological problems.

## OUR CONTACT DETAILS

### Sales and General Enquiries

 1300 ALLIGHT (1300 255 444) (Australia Wide)

 +61 8 9302 7000 (International)

### Tech Help

 1800 681 622 (Technical Help)

 [support@allight.com](mailto:support@allight.com) (for tech support)

 [warranty@allight.com](mailto:warranty@allight.com) (for warranty)

---

---

## 2. INTRODUCTION

### GENERAL

This Operating Manual has been prepared to assist in the operation of your Allight Generator and Lighting Tower.

Using this manual in conjunction with the *Spare Parts and Service and Maintenance Manuals* (available separately) will help to ensure that the lighting tower operates at maximum performance and efficiency for many years.

Please note that in dirty or dusty environments more attention must be paid to frequent servicing to keep the set running properly.

The terms *left* and *right* sides are determined by standing at the rear of the machine and facing in the direction of forward travel.

### SAFETY

Please familiarize yourself with the Safety Precautions in section 6, the Job Safety Analysis in section 8.3 and the Generator and Lighting Tower Operation procedures in section 8.4 prior to using the machine. Failure to do so may cause operating problems, which could affect your warranty.

### SPARE PARTS AND SUPPORT

In all correspondence with Allight, always have the machine build style, machine unit number, and the engine make and serial number available to allow our operators to assist you promptly.

The machine build style can be found on the Quality Assurance documentation sent with your lighting tower Service and Maintenance manuals.





The engine build number and serial number is stamped on the engine block, near the fuel injection pump. Allight's unit no can be found below the Y-shaped mast receiver on mine series lighting towers and on the rear fork lift pocket of the Night shifter series lighting towers.

Always ensure that adjustments and repairs are done by personnel who are authorized to do the work and have been properly trained.

Allight is able to supply all parts and service items required for this equipment.

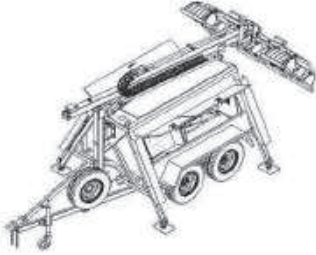
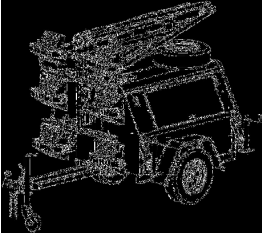
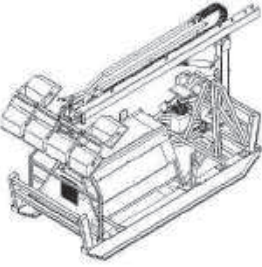
### 3. IDENTIFICATION

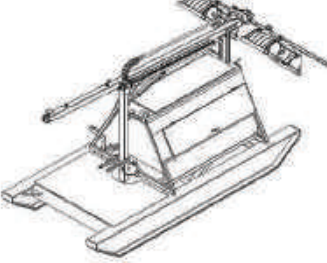
Note: Illustrated Models may contain non-standard options and accessories

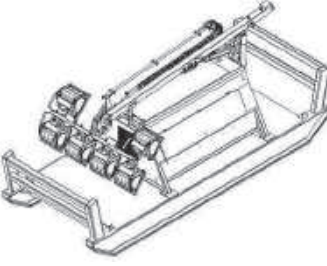
 <p><b>NM-9 SERIES</b> NIGHTSHIFTER SERIES GENERATOR AND MANUAL LIGHTING TOWER</p>	 <p><b>MS-10 SERIES</b> MINE SERIES GENERATOR AND 10 M HYDRAULIC LIGHTING TOWER</p>
 <p><b>NH-9 SERIES</b> NIGHTSHIFTER HYDRAULIC SERIES GENERATOR AND HYDRAULIC LIGHTING TOWER</p>	 <p><b>SB-12 SERIES</b> SKID BASE GENERATOR AND 12 M HYDRAULIC LIGHTING TOWER</p>
 <p><b>MS-M SERIES</b> MINE SERIES GENERATOR AND 8.5 M MANUAL LIGHTING TOWER</p>	 <p><b>SB-9 SERIES</b> SKID BASE GENERATOR AND 9 M HYDRAULIC LIGHTING TOWER</p>
 <p><b>MS-9 SERIES</b> MINE SERIES GENERATOR AND 9 M HYDRAULIC LIGHTING TOWER</p>	 <p><b>SB-10 SERIES</b> SKID BASE GENERATOR AND 10 M HYDRAULIC LIGHTING TOWER</p>

## 4. SPECIFICATION

	Model	NM-9	NH-9 (6K)	NH-9 (9K)	MS-M	MS-9	MS-10
<b>General</b>	<b>Mast Height</b>	8.5M	9.5M	9.5M	8.5 M	9.0 M	10.0 M
	<b>Indicative Run Time</b>	4.0KW – 45 Hours	6.0KW – 48 Hours	9.0KW – 30 Hours	4.5 KW - 70 Hours 6.0 KW – 55 Hours	4.5 KW - 70 Hours 6.0 KW – 55 Hours	9.0 KW – 60 Hours 12.0 KW – 45 Hours
	<b>Battery</b>	12V	12V	12V	12V	12V	12V
	<b>High wall reach From Centre Line</b>	N/A	3 M	3 M	N/A	4.7 M	6.0 M
<b>Engine</b>	<b>Model</b>	Perkins 403C-11 Cat 3011C	Perkins 403C-11 Cat 3011C	Perkins 403C-15 Cat 3015C	Perkins 403C-11	Perkins 403C-11	Perkins 404C-22
	<b>Type</b>	<ul style="list-style-type: none"> <li>• 1.1L (67.2 cid)</li> <li>• 3 Cyl.</li> <li>• Water-cooled</li> <li>• Diesel</li> <li>• Naturally Aspirated</li> </ul>	<ul style="list-style-type: none"> <li>• 1.1L (67.2 cid)</li> <li>• 3 Cyl.</li> <li>• Water-cooled</li> <li>• Diesel</li> <li>• Naturally Aspirated</li> </ul>	<ul style="list-style-type: none"> <li>• 1.5L (91.6 cid)</li> <li>• 3 Cyl.</li> <li>• Water-cooled</li> <li>• Diesel</li> <li>• Naturally Aspirated</li> </ul>	<ul style="list-style-type: none"> <li>• 1.1L (67.2 cid)</li> <li>• 3 Cyl.</li> <li>• Water-cooled</li> <li>• Diesel</li> <li>• Naturally Aspirated</li> </ul>	<ul style="list-style-type: none"> <li>• 1.1L (67.2 cid)</li> <li>• 3 Cyl.</li> <li>• Water-cooled</li> <li>• Diesel</li> <li>• Naturally Aspirated</li> </ul>	<ul style="list-style-type: none"> <li>• 2.2L (134.4 cid)</li> <li>• 4 Cyl</li> <li>• Water-cooled</li> <li>• Diesel</li> <li>• Naturally Aspirated</li> </ul>
<b>AC Alternator</b>	<b>Type</b>	<ul style="list-style-type: none"> <li>• Capacitor Controlled</li> <li>• 4 pole, single bearing</li> <li>• Brushless</li> </ul>	<ul style="list-style-type: none"> <li>• Capacitor Controlled</li> <li>• 4 pole, single bearing</li> <li>• Brushless</li> </ul>	<ul style="list-style-type: none"> <li>• Capacitor Controlled</li> <li>• 4 pole, single bearing</li> <li>• Brushless</li> </ul>	<ul style="list-style-type: none"> <li>• AVR Controlled</li> <li>• 4 pole, single bearing</li> <li>• Brushless</li> </ul>	<ul style="list-style-type: none"> <li>• AVR Controlled</li> <li>• 4 pole, single bearing</li> <li>• Brushless</li> </ul>	<ul style="list-style-type: none"> <li>• AVR Controlled</li> <li>• 4 pole, single bearing</li> <li>• Brushless</li> </ul>
<b>Fluid Capacities**</b>	<b>Engine crankcase</b>	3.4L (0.9 US gal)	3.4L (0.9 US gal)	6.0L (1.58 US gal)	3.4L (0.9 US gal)	3.4L (0.9 US gal)	8.9L (2.35 US gal)
	<b>Hydraulic Fluid</b>	N/A	N/A	10 L (2.64 US gal)	N/A	4.3L (1.14 US gal)	10 L (2.64 US gal)
	<b>Engine Coolant</b>	5.8L (1.53 US gal)	5.8L (1.53 US gal)	6.0L (1.58 US gal)	5.8L (1.53 US gal)	5.8L (1.53 US gal)	10 L (2.64 US gal)
<b>Transport Dimensions (Trailer Version)</b>	<b>Length</b>	2.4m (7'10")	2.35m (7'8")	2.35m (7'8")	4.8m (15'9")	5.2m (17'1")	5.7m (18'8")
	<b>Width</b>	1.2m (3'11)	1.45m (4'9")	1.45m (4'9")	1.9m (6'3")	2.1m (6'11")	2.25m (7'5")
	<b>Height</b>	1.4m (4'7")	2.2m (7'2")	2.2m (7'2")	2.6m (8'6")	2.6m (8'6")	2.8m (9'2")
	<b>Gross Weight</b>	840kg (1852lb)	1433 kg (3160lb)	1600kg (3530lb)	1350kg (3970lb)	1500kg (3300lb)	2500kg (5500lb)
<b>Transport Dimensions (Skid Base Version)</b>	<b>Length</b>	N/A	N/A	N/A	4.5m (14'9")	4.5m (14'9")	5.6m (18'4")
	<b>Width</b>	N/A	N/A	N/A	1.8m (6'3")	1.95m (6'5")	2.25m (7'5")
	<b>Height</b>	N/A	N/A	N/A	2.7m (8'10")	2.6m (8'6")	2.5m (8'2")
	<b>Gross Weight</b>	N/A	N/A	N/A	1600kg (3520lb)	1600kg (3520lb)	2700kg (5940lb)

\*\* For recommended fluid types refer to Spare Parts and Service Manual

\*\*\* For non standard builds, please refer to Allight supplied supplements

---

---

## 5. GENERAL DESCRIPTION

### Description

This Allight Generator and Lighting Tower has been designed as a complete package to provide superior performance and reliability. While major components of a typical Generator and Lighting tower are usually similar, sets may be slightly different due to clients' individual specifications. This section briefly describes the parts of the Generator and Lighting Tower.

### Identification

The model and serial numbers uniquely identify the Generator and Lighting Tower and are needed when ordering spare parts or obtaining service or warranty work for the set. The unit number can be found under the mast receiver and/or on the chassis at the rear of the tower.

Each alternator is provided with a **Rating** generally affixed to the alternator housing. This label contains the information needed to identify the alternator and its operating characteristics. This information includes, but is not limited to, the model number, serial number, output characteristics such as voltage, phase and frequency, output rating in kVA and kW, and rating type (basis of the rating).

### Diesel Engine

The diesel engine powering the Generator and Lighting Tower has been chosen for its reliability and the fact that it has been specifically designed for delivering a power supply. The engine is a low speed heavy duty compression ignition industrial 4 stroke and is fitted with all accessories to provide a reliable power supply. These accessories include, among others, cartridge type filters, mechanical A1 class engine governor and most models include sealed crankcase ventilation.

### Cooling System

The engine cooling system is comprised of a high capacity pusher fan and a thermostat. The alternator has its own internal fan to cool the alternator components. Note that the air is "pushed" through the radiator so that the air is drawn past the alternator, then past the engine and finally through the radiator.

### 12 Volt Engine Electrical System

The engine electrical system is 12 volts DC, negative ground/earth. This system includes an electric engine starter, battery charging alternator/dynamo and battery. Lead-acid batteries are supplied as standard; other battery types are available as an option.

### Engine Protection Shutdown System

This system is designed to stop the engine in the event of low oil pressure and high coolant temperature with an option for low coolant level.

### AC Alternator

The alternator is rated to the power requirement of the machine and is direct coupled to the engine with a flexible drive plate.

### AC Output Circuit Breakers

To protect the AC circuit, a suitably rated overload circuit breaker selected for the lighting tower model and output rating is supplied. See the AC Electrical Operating and Fault Finding section for a full description.

### Hydraulic Controls (if fitted)

Situated on the left hand side of the control enclosure. Signage is provided above the controls to indicate movement of mast direction and other hydraulic functions.

### Timer Shutdown System (if fitted)

After starting engine, the timer shutdown system engages and will shut down Generator and trip the main circuit breaker at a pre-set time.

---

---

## Components referred to in this Manual

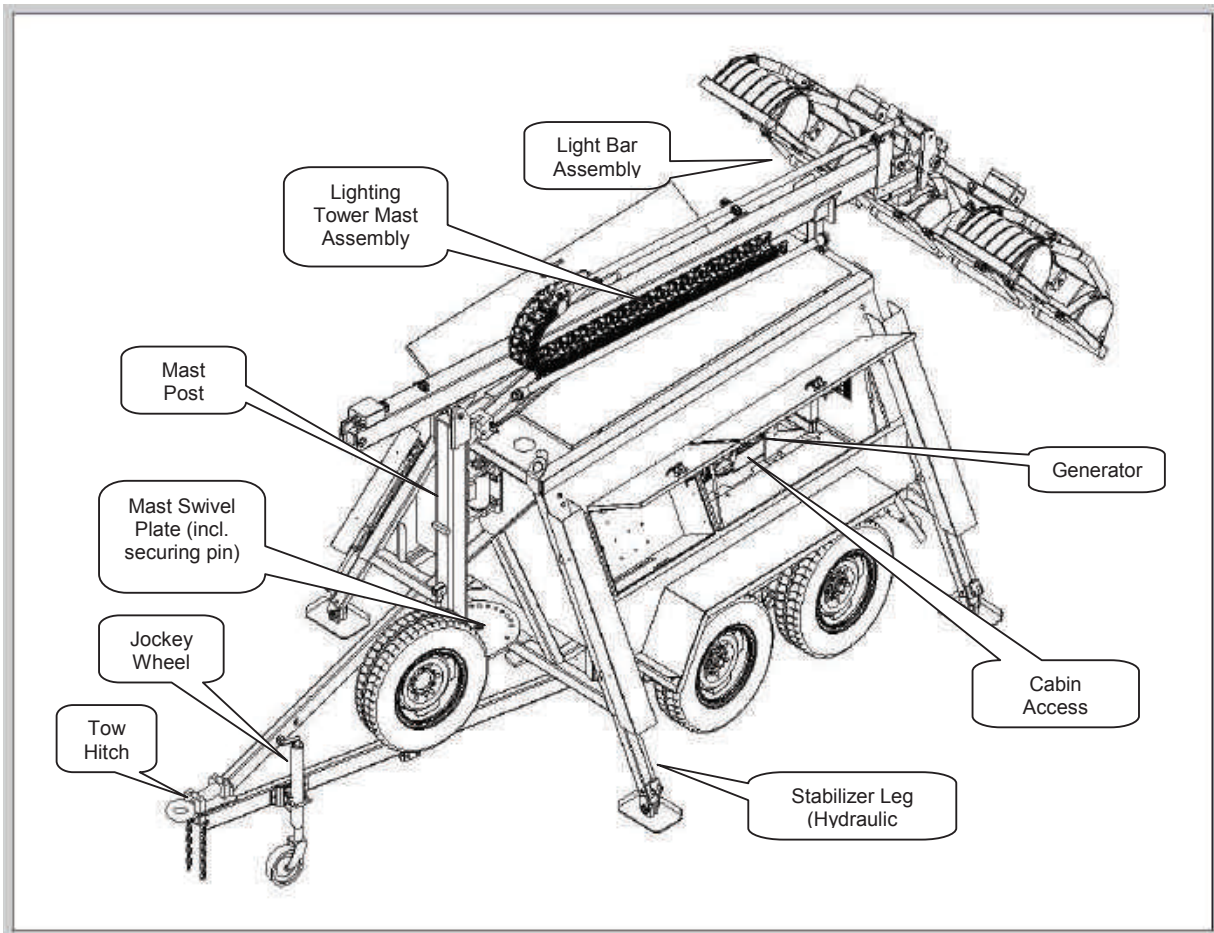

*Typical arrangement for MS-10 series tandem axle Generator and Lighting tower.*

---

---

## 6. SAFETY PRECAUTION

- **This section is for information purposes only, and is not a safety manual. Allight encourages thorough training, and maintenance of high safety standards in the use of this equipment, but responsibility for compiling proper safety instructions rests with the owner of the product. For any queries, contact Allight personnel at your nearest branch.**

### General

The Generator and Lighting Tower is designed to be safe when used in the correct manner. Responsibility for safety, however, rests with the personnel who install, use and maintain the set. The following safety precautions, if followed, will minimize the possibility of accidents. Before performing any procedure or operating technique, it is up to the user to ensure that it is safe. The lighting tower should only be operated by personnel who are authorized and trained. Refer to Job Safety Analysis (JSA) in section 8.3 for details.

- ⚠ **Read and understand all safety precautions and warnings before operating or performing maintenance on the lighting tower.**
- ⚠ **Failure to follow the instructions, procedures, and safety precautions in this manual may increase the possibility of accidents and injuries.**
- ⚠ **Never start the lighting tower unless it is safe to do so.**
- ⚠ **Install and operate this lighting tower only in full compliance with relevant National, Local, or Federal Codes, Standards or other requirements.**

### Handling and Towing

This manual should be read before lifting or towing the Generator and Lighting Tower.

#### Lifting

- Never lift machine by slinging to the Mast.
- Do not lift unit with a forklift (NM-9 and ML-9 Series excepted).
- Only qualified personnel are to use lifting equipment.
- Do not lift the lighting tower by the mast. (Use ALL lifting points provided).

- Ensure the lifting equipment is in good condition and has a capacity suitable for the load.
- Hoisting acceleration should not exceed 0.4m/sec<sup>2</sup>.
- Keep all personnel away from the unit when it is suspended.

#### Securing positions

- The unit should only be secured to a carrying vehicle by chaining or slinging the axle(s) for the MS Series or the indicated tie down points for NM-9 Series. Do not chain or sling across the drawbar or mast as damage will occur.

⚠ **Ensure the lifting rigging and supporting structure is in good condition and has a capacity suitable for the load.**

⚠ **Keep all personnel away from the lighting tower when it is suspended.**

#### Before towing

- Take care not to reverse vehicle into trailer, as this may damage structural and brake components.
- Check vehicle towing hitch load rating and ball/hitch size and type are compatible with trailer weight.
- Check Mast is in the Y-shaped receiver, that it is fully retracted and that securing devices are locked.
- Check doors are latched.
- Check tyres are correctly inflated & that the tread is roadworthy. Check tyre placard or tyre sidewalls for recommended cold inflation pressures.
- Check all stabilizer legs are raised.
- Connect hitch, towing chains and electrical plug (if fitted) to vehicle.
- Check jockey wheel is fully retracted and secured horizontally.
- Store wheel chocks (if supplied).
- Check that the brake reversing lock tab on hitch is open (if brakes are fitted).
- Check brake fluid level, brake operation, cables are not frayed, and that adjustment is correct (if brakes are fitted). Check brake fluid pressure by pulling on the brake handle - pressure should be felt on the first stroke. Rectify if necessary.
- Check tail light operation (if lights are fitted).

⚠ **When towing a mobile Generator and Lighting Tower, observe all Codes, Standards or other regulations and traffic laws. These include those regulations**

specifying required equipment and maximum and minimum speeds.

- ⚠ **Maximum recommended towing speed on sealed surfaces is 80 km/h (dependent on conditions and local limits).**
- ⚠ **Maximum recommended towing speed on unsealed surfaces is 30km/h (dependent on conditions and local limits).**
- ⚠ **Maximum recommended towing speed for skid mounted plant is 5km/h.**
- ⚠ **Do not permit personnel to ride in or on the plant. Do not permit personnel to stand or ride on the drawbar or to stand or walk between the trailer and the towing vehicle.**

### Unhitching trailer

- Check that the ground is level, the surface secure, and the position is not too close to a dropping embankment.
- Check parking brake is applied on the towing vehicle, and apply parking brake on tower.
- Install wheel chocks (if supplied) ensuring that the tower will not roll down any incline.
- Remove chains and electrical plug (if fitted).
- Set the jockey wheel in place ensuring that the swivel plate locks into the vertical position.
- Raise trailer from hitch using the jockey wheel.
- Lower stabilizer legs.

## Set Up

### Before starting Generator

- Check all conduits for splits, bare wires or unsecured conduit fittings.
- Check that all circuit breaker boards are secure and sealed.
- Check that all covers and caps are secure on alternator, cooling fan/radiator, engine & fuel tank.
- Check tower is level on secure ground and stabilizer legs are down, with wheel chocks in place (if fitted).

## Operating

- On manual mast raise models (NM-9 and MS-M), check that the mast securing lock activates before extending inner.
- Before lowering mast, be sure inner mast is fully retracted.
- ⚠ **Do not operate within a confined space.**
- ⚠ **Do not move tower with generator running, or before the mast is retracted in its cradle.**

- ⚠ **Ensure operating area is clear of overhead power lines and any other obstruction before raising mast.**
- ⚠ **Do not operate with a damaged or missing lens or an open light, otherwise skin/eye damage can occur.**
- ⚠ **Avoid looking directly at lights or standing within 8 meters of lights when operating**
- ⚠ **To avoid risk of injury, never lower a manual mast without the inner mast fully retracted. Do not tamper with the safety lock pin at the base of the mast. When the inner mast is fully lowered the lock will release.**
- ⚠ **Do not attempt to operate the Generator and Lighting Tower with a known unsafe condition. If the unit is unsafe, tag the machine *out of service* (per site procedures) and isolate the battery (using battery isolator) so that it cannot be started until the condition is corrected.**
- ⚠ **Do not operate the Generator and Lighting tower in any classification of hazardous environment unless approved by Allight.**
- ⚠ **Do not operate the Lighting Tower if there is risk of wind gusts greater than 100 km/h.**

## Hazards

### Fire and Explosion

Fuels and fumes associated with Generators can be flammable and potentially explosive. Proper care in handling these materials can dramatically limit the risk of fire or explosion. However, safety dictates that fully charged fire extinguishers are kept on hand. Personnel must know how to operate them.

- ⚠ **Never store flammable liquids near the Generator.**
- ⚠ **Store oily rags in metal covered containers.**
- ⚠ **Do not smoke or allow sparks, flames or other sources of ignition around fuel or batteries. Fuel vapors are explosive. Hydrogen gas generated by charging batteries is also explosive.**
- ⚠ **Turn off or disconnect the power to the battery charger (if fitted) before making or breaking connections with the battery.**
- ⚠ **Keep grounded conductive objects, such as tools, away from exposed live electrical parts, such as terminals, to avoid arcing.**

Sparks and arcing might ignite fuel or vapors.

- ⚠ Do not refill the fuel tank while the engine is running.
- ⚠ Do not attempt to operate the Generator with any known leaks in the fuel system.

#### Mechanical

The Generator and Lighting tower is designed with guards for protection from moving parts. Care must still be taken to protect personnel and equipment from other mechanical hazards when working around the lighting tower.

- ⚠ Do not attempt to operate the Generator or Lighting tower with any safety guards or panels removed.
- ⚠ During operation, do not attempt to reach under or around the guards for any reason.
- ⚠ Ensure that the Generator is operated only from the control panel or from the operator's position by one person only.
- ⚠ Keep hands, arms, long hair, loose clothing and jewelry away from pulleys, belts and other moving parts. Note that some moving parts cannot be seen clearly when the set is running.
- ⚠ Keep access doors on enclosures, if equipped, closed and locked when not required to be open.
- ⚠ Avoid contact with hot oil, hot coolant, hot exhaust gases, hot surfaces and sharp edges and corners.
- ⚠ If your skin comes into contact with high pressure fuel, obtain medical assistance immediately.
- ⚠ If your skin comes into contact with high pressure hydraulic oil, obtain medical assistance immediately.
- ⚠ Wear protective clothing including gloves and hat when working around the Generator and Lighting Tower.
- ⚠ Do not remove the radiator filler cap until the coolant has cooled. Then loosen the cap slowly to relieve any excess pressure before removing the cap completely.
- ⚠ Ethyl Ether starting aids must not be used on engines with combustion air preheating

devices. In general these starting aids are not recommended on any engine. They will reduce the efficient working life of the engine.

#### Chemical

Fuels, oils, coolants, lubricants and battery electrolyte used in this Generator are typical of the industry. However, they can be hazardous to personnel if not treated properly.

- ⚠ Do not swallow or have skin contact with fuel, oil, coolant, lubricants or battery electrolyte. If swallowed, seek medical treatment immediately.
- ⚠ Do not induce vomiting if fuel is swallowed. For skin contact, wash with soap and water.
- ⚠ Do not wear clothing that has been contaminated by fuel or lube oil.
- ⚠ Wear an acid resistant apron and face shield or goggles when servicing the battery. If electrolyte is spilled on skin or clothing, flush immediately with large quantities of water.

#### Noise

Generators that are not equipped with sound attenuating enclosures can produce noise levels in excess of 85 dBA. Prolonged exposure to noise levels above 85 dBA is hazardous to hearing.

- ⚠ Ear protection must be worn when operating or working around the Generator and Lighting Tower.

#### Electrical

- ⚠ Do not attempt to connect or disconnect load while standing in water or on wet or soggy ground.
- ⚠ Be sure all electrical power is isolated from electrical equipment being serviced.
- ⚠ Keep all electrical equipment clean and dry. Replace any wiring where the insulation is cracked, cut, abraded or otherwise degraded. Replace terminals that are worn, discoloured or corroded. Keep terminals clean and tight.
- ⚠ Use only fire extinguishers suitable for electrical fires.

---

---

## 7. FIRST AID FOR ELECTRICAL INJURIES

*This section is included for information purposes only and is not a First Aid manual. Medical advice should always be sought in the preparation of procedures, and as soon as possible in an emergency.*

*While Allight encourages thorough training of First Aid personnel, responsibility for compiling adequate First Aid instructions rests with the owner of the product.*

*If you have any comments on this section, please contact Allight personnel at your nearest branch.*

### Dangers

Your first concern is to make sure the electrical current is not still a hazard. Do not touch the victim until you are certain there is no electrical current still present. With a regular household appliance, switch off the main power or remove the plug if it is safe to touch the supply cord. With high-voltage currents, such as from a fallen power line or industrial equipment, stay at least 6 meters away from the power because the electricity can arc quite a distance, especially in wet conditions. Call the electricity supply authority and then wait for the arrival of trained staff or for assurance that the power has been turned off.

### Check the Victim's Response

When it is safe, check whether the victim is conscious. Speak loudly to the victim and gently touch the shoulder. Ask, "Can you hear me?" or "Squeeze my hand." If the victim does not respond to your voice or touch, assume unconsciousness and follow the ABC of resuscitation.

- A. **Airway** – Clear and Open
- B. **Breathing** – Check and be prepared to start EAR.
- C. **Circulation** – Check for circulation and use CPR if there is no pulse.

### Clear and Open the Airway

If there is no response, quickly turn the victim onto one side into the recovery position. Using two fingers, clear the mouth of any food or fluids. Then, gently tilt back the head and support the jaw, keeping the face turned slightly downwards for drainage.

### Check for Breathing

Look and feel over the lower ribs for any chest movement. Listen and feel for the escape of air from the mouth or nose. If there is no sign of breathing, resuscitation is needed, so quickly roll the victim onto their back. Begin mouth to mouth resuscitation (EAR), if you know how. Otherwise, call for help from a trained bystander.

### Expired Air Resuscitation (EAR)

Whilst maintaining head tilt and jaw support, make a tight seal around the victim's mouth with your mouth close the victim's nostrils with your cheek and give five initial breaths in about 10 seconds. Breathe into the victim until you see the chest rise. Allow the chest to empty whilst your mouth and nose are turned to the side to avoid the exhaled air.

### Check for Circulation

After five breaths have been given, check the pulse in the neck to feel if the heart is beating. If a pulse can be felt, continue EAR at the slower rate of 1 breath every 4 seconds. Recheck the pulse every two minutes to be sure that the heart is still beating. If you cannot feel a pulse, begin cardiopulmonary resuscitation (CPR) if you have been trained.

### Cardiopulmonary Resuscitation (CPR)

Find the lower edge of victim's rib cage with your lower hand. Slide your index finger up the edge of the rib cage to the notch where the ribs meet the sternum. Leave your index finger on this notch. With the index finger of your upper hand, find the notch at the top of the sternum where the collarbones join it. Leave your index finger on this notch.

Extend both thumbs equally to find the middle of the sternum. Place the heel of your compressing hand on the sternum just below the midpoint. Grasp the wrist of the hand on the chest with your other hand and compress the chest.

CPR is given in cycles of 15 compressions and 2 breaths. This cycle should take about 15 seconds.

After 4 cycles (1 minute), check for a pulse. If there is no pulse continue CPR and check for a pulse every two minutes until emergency personnel arrive.

---

---

## Shock

Most injured people show the signs and symptoms of shock. These are:

- Pale, cool, moist skin.
- A weak, rapid pulse.
- Altered conscious states.
- Rapid breathing.
- Nausea / vomiting.
- Restlessness / irritability.
- Extreme thirst.

Do not give any food, fluids or stimulants. Where possible, the conscious victim should be assisted to lie down in the most comfortable position with all injured parts supported. If injuries permit, raise both legs to boost the circulation to the heart and brain. The unconscious victim should be placed in the recovery position. Maintain the victim's body temperature.

## Burns

Electrical burns are often deep, and the victim will have both an entrance and exit wound. Although these wounds may look superficial, the tissues below may be severely damaged. After ensuring the scene is safe:

- Cool burns by flushing with cool water
- Remove victims rings and jewellery (metal retains heat)
- Cover the burn with a dry, sterile dressing
- Take steps to minimize shock

 **In all emergencies call Emergency Services as soon as possible.**

### Australian Red Cross

Information supplied by Australian Red Cross. To respond appropriately in a first aid emergency, the international Red Cross and Red Crescent organizations recommend completing a first aid course.

To contact the Red Cross or Red Crescent organization in your country, go to <http://www.ifrc.org/>

Follow the links for the service in your country.

---

---

## 8. OPERATING INSTRUCTIONS



*MS-9 series single axle (foreground)*  
*MS-10 series tandem axle (background)*

---

---

## 8.1 CONTROL IDENTIFICATION

### GENERAL ARRANGEMENT

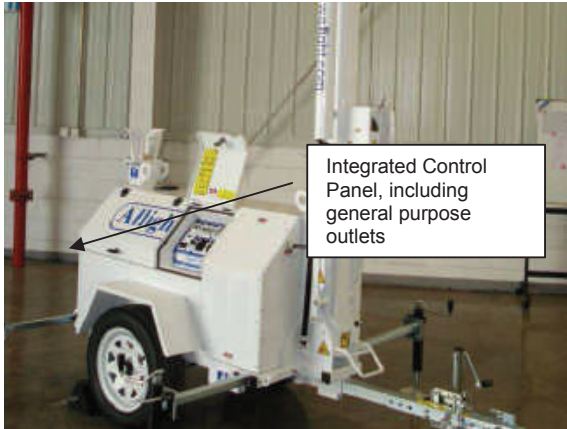

**NM-9 Series**

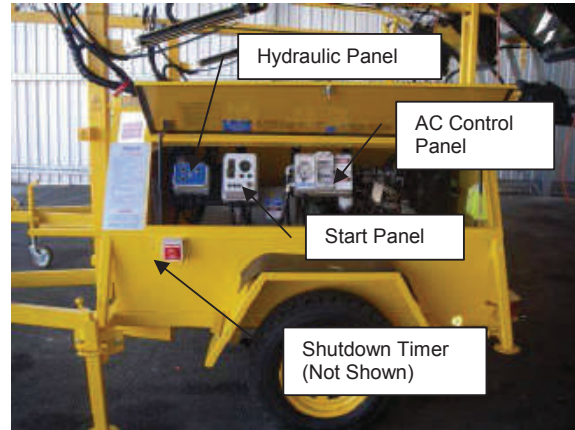

**MS-9 Series**

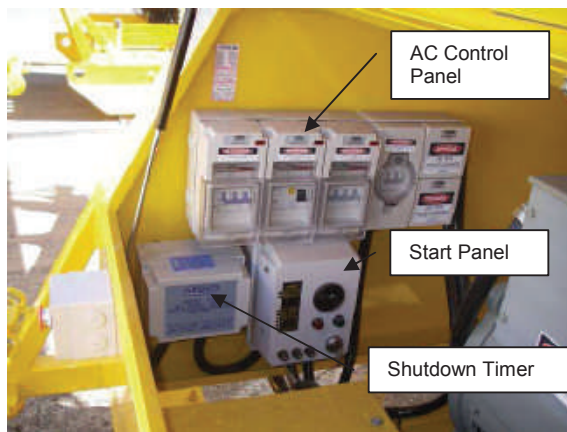

**MS-M Series**

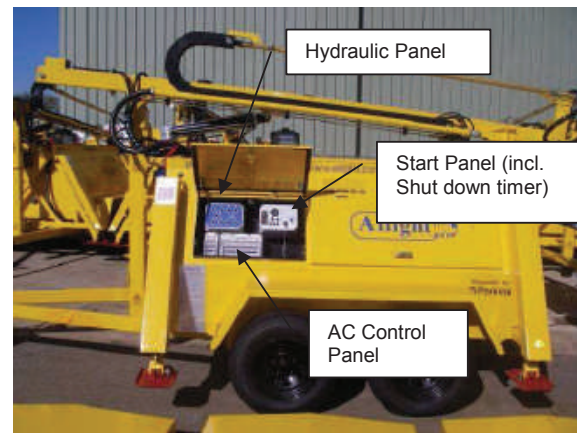

**MS-10 Series**



**NH-9 Series**

Note: Arrangement shown above applies to equivalent Skid Based Tower.

## 8.2 TYPICAL DECALS

Decal	Definition
<p style="text-align: center;">SAFETY DECALS</p>	<p>Read Operation manual before operating. If unsure, contact Allight</p>
	<p>Do not lift from Lighting Tower mast – always use lifting points provided</p>
	<p>MAXIMUM recommended towing speed on smooth road or unsealed surfaces</p>
	<p>Do not tow unit with Lighting Tower mast raised Take care when reversing not to hit obstacles</p>
	<p>Do not tow unit over unsafe surfaces Always ensure stabilizer legs and jockey wheel are deployed and unit is level before operating.</p>
	<p>Do not operate in confined spaces. Always stay clear of obstructions</p>
	<p>Do not operate with overhead obstructions, in particular power lines Always ensure sufficient distance between operator/bystanders and operational lights</p>
	<p>NEVER look directly at operational lights DO NOT set up lighting tower on uneven surfaces</p>



Warning: Hot exhaust and exhaust fumes in vicinity



Warning: Foot crush risk



Warning: Keep head clear when lowering Lighting Tower mast



Warning: Hot surface



Warning: Pinch point risk



MAXIMUM towing speed advise



Electrical Energy inside enclosure. Isolate elsewhere before opening and commencing work.

NOTE: Electrical components are only to be service by suitably qualified personnel.



Securing point for machine transportation tie-downs



Securing point for light bar travel/tie down straps



Lifting Point



Diesel Fuel Only



Diesel Fuel Level



Battery Isolator Located Inside



Fork lift point



Lock out point

## 8.3 JOB SAFETY ANALYSIS (JSA)

Task	Type of Exposure	Hazard(s)	† Risk Rating	Controls	Model					
					NM-9	NH-9	MS-M	MS-9	MS-10	Skid Base
1	<b>Set up</b> Remove trailer from towing vehicle.	<ul style="list-style-type: none"> <li>Trailer may run away or drop to ground.</li> </ul>	4	<ul style="list-style-type: none"> <li>Engage park brake and lower jockey wheel before disconnecting trailer from towing vehicle.</li> <li>Ensure Trailer is not in the path of other working vehicles.</li> </ul>	✓	✓	✓	✓	✓	
2	<b>Set Up</b> Operation Environment.	<ul style="list-style-type: none"> <li>Setting up Generator and Lighting Tower may be hindered by obstacles that could introduce higher risk factors.</li> </ul>	8	<ul style="list-style-type: none"> <li>Ensure operating area is assessed and all foreseeable risks are controlled.</li> </ul>	✓	✓	✓	✓	✓	✓
3	<b>Set up</b> Ground Condition.	<ul style="list-style-type: none"> <li>Sump oil out of level causing engine damage.</li> <li>Stabiliser legs not able to support unit sufficiently.</li> </ul>	21	<ul style="list-style-type: none"> <li>Ensure unit is set up on firm level ground. Level unit before use. (Item 5)</li> </ul>	✓	✓	✓	✓	✓	✓
4	<b>Set up</b> Fluid levels.	<ul style="list-style-type: none"> <li>Incorrect fluid levels may cause damage to Engine and/or hydraulic pump.</li> </ul>	18	<ul style="list-style-type: none"> <li>Check all fluid levels before use.</li> </ul>	✓	✓	✓	✓	✓	✓
5	<b>Set up</b> Use of stabilizer legs.	<ul style="list-style-type: none"> <li>Unit over turning during set up.</li> <li>Lighting Tower becomes unstable as wind strength increases.</li> </ul>	3	<ul style="list-style-type: none"> <li>Lower and lock stabilizers into position before raising Lighting Tower Mast.</li> </ul>	✓	✓	✓	✓	✓	
6	<b>Set up</b> Lowering of hydraulic stabilizer legs (if fitted).	<ul style="list-style-type: none"> <li>Hydraulic leg may become crush point for operator or other's feet.</li> </ul>	17	<ul style="list-style-type: none"> <li>Ensure path of hydraulic legs is clear of people.</li> <li>Stand clear when lowering stabilizer legs.</li> </ul>		✓		✓	✓	
7	<b>Set up</b> Lowering of manual stabilizer legs (if fitted).	<ul style="list-style-type: none"> <li>Spring pin for actuating manual leg may become encrusted with dirt and mud.</li> <li>Drop down leg may become crush point for operator or other's feet.</li> </ul>	18	<ul style="list-style-type: none"> <li>Ensure spring pins are clean and free of dirt and mud before attempting to actuate.</li> <li>Stand clear of rear drop down legs when lowering stabilizer legs.</li> </ul>	✓	✓	✓	✓		
8	<b>Set up</b> Service Intervals.	<ul style="list-style-type: none"> <li>Lighting Tower becoming electrically or mechanically unsafe.</li> <li>Generator and/or Engine damage.</li> </ul>	2	<ul style="list-style-type: none"> <li>Check last service sticker or release tags.</li> </ul>	✓	✓	✓	✓	✓	✓
9	<b>Set up</b> Release Load Binders on light bar.	<ul style="list-style-type: none"> <li>Mast will not rise.</li> <li>Load binders may release in uncontrolled manner.</li> </ul>	21	<ul style="list-style-type: none"> <li>Release Load Binder before raising mast.</li> <li>Release load binders slowly and with care.</li> </ul>	✓	✓	✓	✓	✓	✓
10	<b>Set Up</b> Remove retaining pin from light bar receiver	<ul style="list-style-type: none"> <li>Mast will not raise</li> </ul>	21	<ul style="list-style-type: none"> <li>Ensure pin is removed during set up</li> </ul>	✓					
11	<b>Set Up</b> Mast Raise to vertical	<ul style="list-style-type: none"> <li>Pushing down on mast tilt handle at incorrect angle</li> </ul>	18	<ul style="list-style-type: none"> <li>Ensure light bar assembly is lifted out of receiver using handle provided before pushing down</li> </ul>	✓					
12	<b>Set Up</b> Lock Mast into vertical position	<ul style="list-style-type: none"> <li>Mast may fall if not locked into position</li> </ul>	7	<ul style="list-style-type: none"> <li>Ensure locking pin is activated</li> <li>Test operation of secondary safety catch regularly</li> </ul>	✓		✓			

Task	Type of Exposure	Hazard(s)	† Risk Rating	Controls	Model					
					NM-9	NH-9	MS-M	MS-9	MS-10	Skid Base
13	<b>Start up</b> Light circuit breakers are switched OFF.	<ul style="list-style-type: none"> <li>Turning engine ON with circuit breakers ON may cause alternator damage.</li> </ul>	18	<ul style="list-style-type: none"> <li>Turn all light circuit breakers OFF before turning engine ON.</li> <li>Circuit breakers may be turned ON once engine is ON.</li> </ul>	✓	✓	✓	✓	✓	✓
14	<b>Start up</b> Raising and Rotating Mast.	<ul style="list-style-type: none"> <li>Rotating mast post when Mast is not vertical may result in overturning of the machine.</li> </ul>	12	<ul style="list-style-type: none"> <li>Rotate mast post only when Mast is in a 100% vertical position.</li> </ul>	✓	✓	✓	✓	✓	✓
15	<b>Start Up</b> Operation of Mast assembly.	<ul style="list-style-type: none"> <li>Extended use of hydraulic motor may result in thermal overload.</li> </ul>	19	<ul style="list-style-type: none"> <li>Set up by performing tasks in a safe and efficient manner.</li> </ul>		✓		✓	✓	✓
16	<b>Start Up</b> Light Bar tilt position	<ul style="list-style-type: none"> <li>Mast assembly may bind if light tilt is not vertical</li> </ul>	18	<ul style="list-style-type: none"> <li>Ensure light tilt is vertical before extending mast</li> </ul>	✓					
17	<b>Start Up</b> Use of manual winch to extend mast assembly.	<ul style="list-style-type: none"> <li>Damaged cable may break leading to uncontrolled decent of second stage.</li> </ul>	17	<ul style="list-style-type: none"> <li>Inspect winch cable regularly for wear or damage.</li> <li>Replace cable at any sign of wear or damage.</li> </ul>	✓		✓			✓
18	<b>Start Up</b> Use of manual winch	<ul style="list-style-type: none"> <li>Poor winding technique may introduce strain</li> </ul>	21	<ul style="list-style-type: none"> <li>Ensure winch is operated in smooth, controlled fashion</li> </ul>	✓		✓			✓
19	<b>Start up</b> Mast Post Swivel Plate (Manual mast post rotation variants only).	<ul style="list-style-type: none"> <li>Mast post is exposed to rotational forces due to wind loading, which may result in overturning of the machine.</li> </ul>	12	<ul style="list-style-type: none"> <li>Ensure swivel plate at base of mast post is pinned or locked in position after rotating.</li> </ul>	✓	✓	✓	✓	✓	✓
20	<b>Start up</b> Test RCD.	<ul style="list-style-type: none"> <li>Faulty RCD may lead to electrocution.</li> </ul>	4	<ul style="list-style-type: none"> <li>Push TEST button.</li> </ul>	✓	✓	✓	✓	✓	✓
21	<b>Operating</b> Proximity to lights.	<ul style="list-style-type: none"> <li>Lights produce high UV that may damage skin or eyes.</li> </ul>	8	<ul style="list-style-type: none"> <li>Do not look directly at lights.</li> <li>Maintain a distance of <b>8 METRES</b> from lights at all times.</li> <li>Ensure all affected employees are informed of safety distance.</li> </ul>	✓	✓	✓	✓	✓	✓
22	<b>Operating</b> Light Condition.	<ul style="list-style-type: none"> <li>Lights produce extreme UV without glass lens fitted that may damage skin or eyes very quickly.</li> </ul>	8	<ul style="list-style-type: none"> <li>Do not use lights without glass lenses.</li> </ul>	✓	✓	✓	✓	✓	✓
23	<b>Operating</b> Electrical Energy.	<ul style="list-style-type: none"> <li>Generator produces Low voltage at 240/415VAC.</li> </ul>	7	<ul style="list-style-type: none"> <li>Avoid using in wet areas.</li> <li>Check all wiring and cables before use.</li> <li>Test RCD by pushing the TEST button.</li> <li>Do not open any AC controls whilst machine is running.</li> <li>Electrical work by a qualified electrician only.</li> <li>Close cabin doors once running.</li> </ul>	✓	✓	✓	✓	✓	✓
24	<b>Operating</b> Moving unit during operation.	<ul style="list-style-type: none"> <li>Unit may overturn if moved whilst running or if mast is raised or extended.</li> </ul>	5	<ul style="list-style-type: none"> <li>Do not move whilst running or set up</li> <li>Follow correct shutdown procedures are followed before moving machine.</li> </ul>	✓	✓	✓	✓	✓	✓

Task	Type of Exposure	Hazard(s)	† Risk Rating	Controls	Model					
					NM-9	NH-9	MS-M	MS-9	MS-10	Skid Base
25	<b>Operating</b> Fuel Level	<ul style="list-style-type: none"> <li>May cause damage to engine.</li> </ul>	18	<ul style="list-style-type: none"> <li>Do not allow tank to empty below 1/6<sup>th</sup> full.</li> </ul>	✓	✓	✓	✓	✓	✓
26	<b>Operating</b> Operation in a confined space or flammable area.	<ul style="list-style-type: none"> <li>May cause fire or diesel fume damage.</li> </ul>	7	<ul style="list-style-type: none"> <li>Do not run in combustible area or confined space.</li> <li>Allow minimum 3 m horizontal clearance area around generator.</li> </ul>	✓	✓	✓	✓	✓	✓
27	<b>Operating</b> Frequency of fluid level checks.	<ul style="list-style-type: none"> <li>Low fluid level may cause irreparable damage to unit.</li> </ul>	18	<ul style="list-style-type: none"> <li>Check fluid levels when refueling.</li> </ul>	✓	✓	✓	✓	✓	✓
28	<b>Operating</b> Wind Gusts	<ul style="list-style-type: none"> <li>Wind gusts in excess of 100 km/h may cause Lighting Tower mast to become unstable</li> </ul>	7	<ul style="list-style-type: none"> <li>Do not use Lighting tower mast if wind gusts in excess of 100 km/h are expected or forecast.</li> </ul>	✓	✓	✓	✓	✓	
29	<b>Shutdown</b> Circuit breakers.	<ul style="list-style-type: none"> <li>Shutting down engine with circuit breakers ON may cause damage to alternator.</li> </ul>	18	<ul style="list-style-type: none"> <li>Turn OFF all circuit breakers before switching engine OFF.</li> </ul>	✓	✓	✓	✓	✓	✓
30	<b>Shutdown</b> Rotation of Mast Post swivel.	<ul style="list-style-type: none"> <li>Unit may overturn if Lighting Tower mast lowered with mast post swivel off-centre.</li> </ul>	12	<ul style="list-style-type: none"> <li>Ensure mast post swivel is locked in centre position before lowering Mast.</li> </ul>	✓	✓	✓	✓	✓	✓
31	<b>Shutdown</b> Retracting Inner Mast.	<ul style="list-style-type: none"> <li>Unit may overturn if Mast is lowered with inner extended.</li> </ul>	12	<ul style="list-style-type: none"> <li>Do not lower Mast until inner Mast is retracted.</li> <li>Ensure all interlocks are operating correctly</li> </ul>	✓	✓	✓	✓	✓	✓
32	<b>Shutdown</b> Securing light bar.	<ul style="list-style-type: none"> <li>Damage to lights when towing may occur if light bar is not correctly secured.</li> </ul>	14	<ul style="list-style-type: none"> <li>Ensure Mast is lowered into mast receiver.</li> <li>Secure light bar with load binders.</li> </ul>	✓	✓	✓	✓	✓	✓
33	<b>Shutdown</b> Engine shutdown sequence.	<ul style="list-style-type: none"> <li>Turning engine off prematurely may cause battery to become flat.</li> </ul>	19	<ul style="list-style-type: none"> <li>Ensure all ancillary shutdown functions are complete before turning engine OFF.</li> </ul>	✓	✓	✓	✓	✓	✓
34	<b>Shutdown</b> Raising Stabiliser legs.	<ul style="list-style-type: none"> <li>Tower may roll away if handbrake is not applied before raising stabilizer legs.</li> </ul>	13	<ul style="list-style-type: none"> <li>Do not retract stabilizer legs until hand brake is confirmed to be properly applied.</li> </ul>	✓	✓	✓	✓	✓	
35	<b>Moving</b> Jockey Wheel.	<ul style="list-style-type: none"> <li>Jockey wheel may be damaged if not raised before moving.</li> </ul>	22	<ul style="list-style-type: none"> <li>Do not move trailer if jockey wheel still down.</li> <li>Ensure jockey wheel is swiveled into horizontal position before moving.</li> </ul>	✓	✓	✓	✓	✓	
36	<b>Moving</b> Tow Hitch Connection.	<ul style="list-style-type: none"> <li>Incorrect fitting may result in trailer coming loose from towing vehicle's hitch.</li> </ul>	5	<ul style="list-style-type: none"> <li>Ensure tow hitch is connected correctly and break away chains are attached to towing vehicle.</li> </ul>	✓	✓	✓	✓	✓	
37	<b>Moving</b> Hydraulic brakes (if fitted).	<ul style="list-style-type: none"> <li>Low fluid levels may lead to insufficient braking.</li> </ul>	8	<ul style="list-style-type: none"> <li>Check for sufficient brake fluid before towing.</li> </ul>		✓	✓	✓	✓	
38	<b>Moving</b> Releasing Handbrake.	<ul style="list-style-type: none"> <li>Towing trailer with handbrake ON will lead to brakes burning out.</li> </ul>	19	<ul style="list-style-type: none"> <li>Ensure handbrake is released once tow hitch and break away chains are fitted.</li> </ul>		✓	✓	✓	✓	
39	<b>Moving</b> Tyre Pressure.	<ul style="list-style-type: none"> <li>Dangerous to tow with flat or damaged tyres.</li> </ul>	9	<ul style="list-style-type: none"> <li>Check tyres for condition and correct inflation before towing.</li> </ul>	✓	✓	✓	✓	✓	
40	<b>Moving</b> Tail light operation.	<ul style="list-style-type: none"> <li>Legislative requirements</li> <li>Signals must be operational to indicate vehicles intention to other traffic.</li> </ul>	8	<ul style="list-style-type: none"> <li>Ensure tail light plug is fitted to vehicle before moving</li> <li>Check tail light operation before moving.</li> </ul>	✓	✓	✓	✓	✓	

Task	Type of Exposure	Hazard(s)	† Risk Rating	Controls	Model					
					NM-9	NH-9	MS-M	MS-9	MS-10	Skid Base
41	<b>Moving</b> Towing speed.	<ul style="list-style-type: none"> <li>Dangerous to tow trailer at high speeds.</li> <li>May over turn or lose control.</li> </ul>	8	<ul style="list-style-type: none"> <li>Max. speed 80 km/h when towing on sealed road.</li> <li>Less than 30 km/h on unsealed roads or as conditions allow.</li> </ul>	✓	✓	✓	✓	✓	
42	<b>Moving</b> Towing speed	<ul style="list-style-type: none"> <li>Dangerous to tow/push skid at high speeds.</li> <li>May over turn or lose control.</li> </ul>	8	<ul style="list-style-type: none"> <li>Tow/push at speeds less than 5 km/h or as conditions allow.</li> </ul>						✓
43	<b>Moving</b> Lifting unit.	<ul style="list-style-type: none"> <li>Unit may fall if not secured correctly.</li> </ul>	7	<ul style="list-style-type: none"> <li>Lift with using all 4 lifting points only or forklift pockets where available.</li> </ul>	✓	✓	✓	✓	✓	✓
44	<b>Moving</b> Use of push bar, towing eyes and chains (if fitted).	<ul style="list-style-type: none"> <li>Damage may occur to unit if not used correctly.</li> </ul>	13	<ul style="list-style-type: none"> <li>Use Push Bar to push unit only.</li> <li>Use chains supplied and towing eyes to tow unit.</li> </ul>						✓
45	<b>Hazard</b> Battery contains battery acid.	<ul style="list-style-type: none"> <li>Dangerous chemical may cause acid burns.</li> </ul>	18	<ul style="list-style-type: none"> <li>Take care when topping up or checking battery.</li> <li>Observe MSDS requirements.</li> </ul>	✓	✓	✓	✓	✓	✓
46	<b>Hazard</b> Generator uses diesel fuel.	<ul style="list-style-type: none"> <li>Combustible fluid may ignite and is an environmental hazard.</li> </ul>	16	<ul style="list-style-type: none"> <li>Clean up diesel spills and check for leaks. Avoid close exposure to flame.</li> <li>Observe MSDS requirements.</li> </ul>	✓	✓	✓	✓	✓	✓
47	<b>Hazard</b> Trailer may contain brake fluid (if fitted).	<ul style="list-style-type: none"> <li>Dangerous chemical can cause injury if splashed or spilt.</li> </ul>	17	<ul style="list-style-type: none"> <li>Take care when checking or topping up.</li> <li>Observe MSDS requirements.</li> </ul>	✓	✓	✓	✓	✓	
48	<b>Hazard</b> Unit may contain hydraulic oil.	<ul style="list-style-type: none"> <li>Dangerous chemical can cause injury if splashed or spilt.</li> </ul>	17	<ul style="list-style-type: none"> <li>Take care when checking or topping up.</li> <li>Observe MSDS requirements.</li> </ul>		✓		✓	✓	✓
49	<b>Hazard</b> Generator contains engine oil.	<ul style="list-style-type: none"> <li>Environmental spill hazard.</li> </ul>	17	<ul style="list-style-type: none"> <li>Check for leaks, take care not to spill oil on ground when filling or draining.</li> <li>Decant waste oil and dispose properly.</li> <li>Observe MSDS requirements</li> </ul>	✓	✓	✓	✓	✓	✓
50	<b>Hazard</b> Training.	<ul style="list-style-type: none"> <li>Lack of proper training on the use and set up of tower may cause injury to un-qualified operators.</li> </ul>	4	<ul style="list-style-type: none"> <li>Obtain training from Allight or refer to operating manual.</li> </ul>	✓	✓	✓	✓	✓	✓

## Key

Allight Risk Assessment					
Calculate the Risk					
	A	B	C	D	E
1	1 High	2 High	4 High	7 High	11 Significant
2	3 High	5 High	8 High	12 Significant	16 Moderate
3	6 High	9 Significant	13 Significant	17 Moderate	20 Moderate
4	10 Significant	14 Significant	18 Moderate	21 Lower	23 Lower
5	15 Significant	19 Moderate	22 Lower	24 Lower	25 Lower

Note: 1-15 refer to Job Safety Analysis (JSA) before activity commences

### Step 1: Determine Probability

- A. Common or frequent occurrence.
- B. Is known to occur or "it has happened".
- C. Could occur or I've heard of it happening.
- D. Not likely to occur.
- E. Practically impossible.

### Step 2: Determine Consequences (Highest of the two)

- 1. Fatality or permanent disability.
- 2. Serious lost time injury or illness.
- 3. Disabling or short term lost time injury.
- 4. Medical treatment injury.
- 5. First aid injury.

## 8.4 GENERATOR AND LIGHTING TOWER OPERATION

### 8.4.1 Operation Procedures – Nightshifter 4000

#### Step 1



- ⇒ Fit wheel chock.

#### Step 4



- ⇒ Wind down stabilizer leg.

#### Step 2

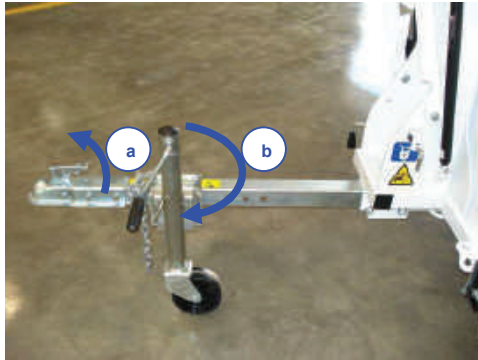

- ⇒ Remove trailer from towing vehicle.
- ⇒ (a) Release lock from tow hitch.
- ⇒ (b) Raise tower from towing vehicle using jockey wheel.

#### Step 5



- ⇒ Repeat for all outriggers and stabilizer legs until unit is level.

#### Step 3

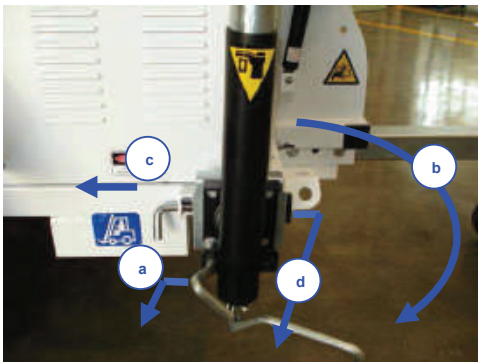

- ⇒ Position Stabilizer Leg.
- ⇒ (a) Release rotation pin on stabilizer leg.
- ⇒ (b) Rotate stabilizer leg to vertical.
- ⇒ (c) Release outrigger retaining pin.
- ⇒ (d) Extend outrigger.

#### Step 6 Generator Only Operation



- ⚠ **For Lighting Tower operation, go to step 7**
- ⇒ (a) Turn key to preheat for 10 seconds (if < 10°C (50°F)).
- ⇒ (b) Turn key to ignition to start generator.
- ⇒ (c) Switch MCB/RCD to “ON”.
- ⇒ (d) Connect leads to outlets and switch outlet circuit breaker to “ON”.

### Step 7

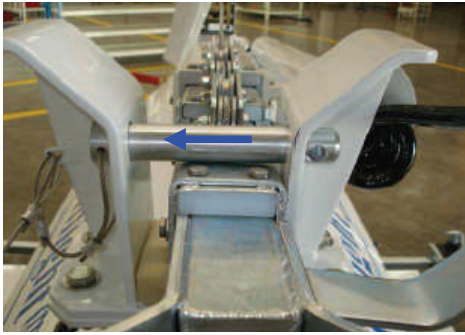

- ⇒ Remove retaining pin from Lighting Tower mast receiver and release light bar tie downs.

### Step 10

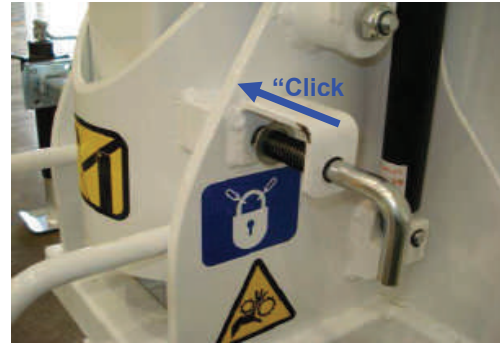

- ⇒ Ensure mast locking pin has engaged.

### Step 8

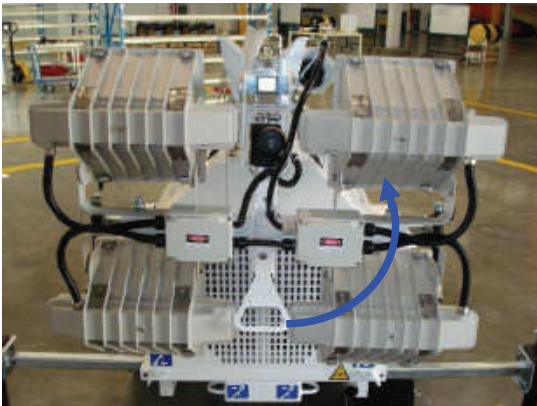

- ⇒ Lift light bar using handle in centre.

### Step 11



- ⇒ Open control panel.
- ⇒ (a) Turn key to run.
- ⇒ (b) Tilt light bar to vertical.

### Step 9



- ⇒ Push down handle to raise mast.

### Step 12

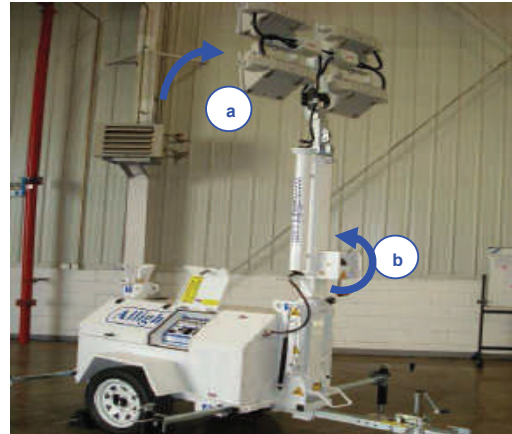

- ⇒ (a) Ensure light bar tilt is in vertical position.
- ⇒ (b) Extend mast by winding winch.

**⚠ Always inspect cable for damage before use. DO NOT use if damage is evident until cable has been replaced.**

### Step 13



- ⇒ Illuminate Lights.
- ⇒ (a) Turn key to preheat for 10 seconds (if < 10°C (50°F)).
- ⇒ (b) Turn key to ignition to start generator.
- ⇒ (c) Switch MCB/RCD to "ON".
- ⇒ (d) Switch each light circuit breaker to "ON".

**⚠ Ensure pre-start checks have been completed prior to operating (see Appendix B)**

### Step 15



- ⇒ Adjust light bar tilt to optimum position to illuminate work area.

### Step 14

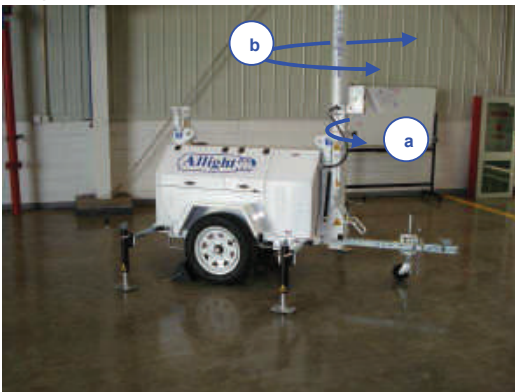

- ⇒ Position Mast Rotation.
- ⇒ (a) Release mast rotation retaining bolt.
- ⇒ (b) Rotate mast to desired position.

## 8.4.2 Shut-down Procedures – Nightshifter Series

### Step 1



- ⇒ Adjust light bar tilt to vertical position.
- ⇒ Rotate Mast to neutral position and engage locking pin.

### Step 3

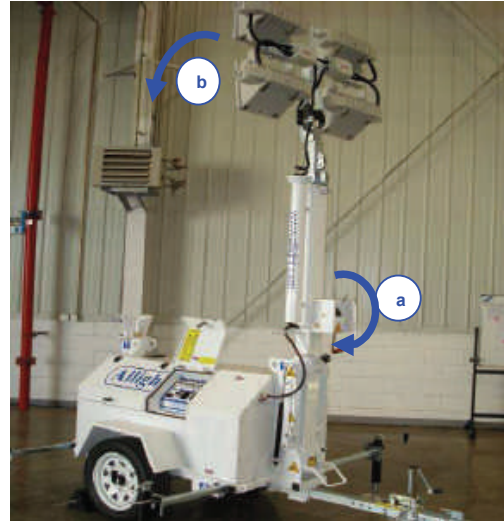

- ⇒ Stow Mast.
- ⇒ (a) Use winch to retract mast.
- ⇒ (b) Adjust light bar tilt to horizontal position.

### Step 2



- ⇒ Shutdown lights and engine.
- ⇒ (a) Turn each light circuit breaker to off.
- ⇒ (b) Turn off main circuit breaker.
- ⇒ (c) Turn engine ignition to off.

### Step 4



- ⇒ Release mast locking pin.

### Step 5



- ⇒ Lower Mast assembly towards mast receiver.

Note that mast will naturally come to rest before seating in receiver.

### Step 6



- ⇒ Move to rear of tower and pull lightbar and mast assembly into receiver using handle.

### Step 7



- ⇒ Insert retaining pin

### Step 8



- ⇒ Stow stabiliser legs. Use jockey wheel to attach lighting tower to towing vehicle.
- ⇒ Retract jockey wheel before driving away.
- ⇒ Ensure rear stabiliser legs are stowed in the horizontal position.

### 8.4.3 Operation Procedures – MS Series and HS Series

#### Step 1

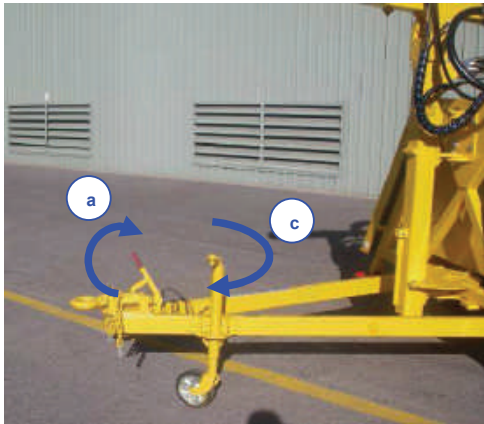

- ⇒ Remove trailer from towing vehicle.
- ⇒ (a) Engage handbrake.
- ⇒ (b) Release lock from tow hitch (not shown).
- ⇒ (c) Raise trailer from towing vehicle using jockey wheel.

#### Step 2



- ⇒ Check battery isolator (if fitted) is turned to the "ON" position. (Single pole shown)

#### Step 3:



- ⇒ Check emergency stop buttons are disengaged (if fitted).

#### Step 4 Hydraulic Stabiliser Legs



- ⇒ Lower stabilizer legs – Hydraulic Legs.
- ⇒ (a) Using marked toggles on hydraulic panel, lower each leg individually until it meets the ground.
- ⇒ (b) Using toggles jog legs as required to ensure firm footprint and level unit

**⚠ Hydraulic legs are for levelling unit only, not for raising unit off ground.**

**⚠ Check area around unit is clear of obstructions and people.**

#### Wind Down Stabiliser Legs



- ⇒ Lower stabilizer legs – Wind-Down Legs.
- ⇒ (a) Release rotation pin on stabilizer leg.
- ⇒ (b) Rotate stabilizer leg to vertical.
- ⇒ (c) Release outrigger retaining pin.
- ⇒ (d) Extend outrigger in direction of (a).
- ⇒ (e) Wind stabilizer legs to ensure tower is level.

### Drop Down Stabiliser Legs

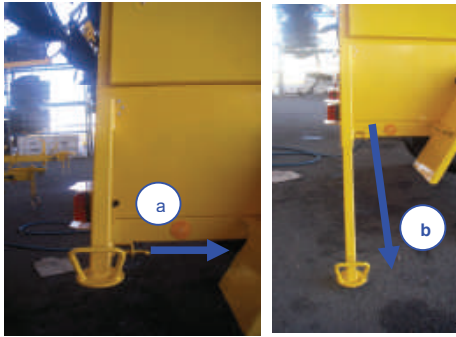

- ⇒ Lower stabilizer legs – Drop-Down Legs.
- ⇒ (a) Pull out retaining pin, whilst supporting drop down leg.
- ⇒ (b) Lower leg into position. Ensure pin is secure in locating hole and securing device is used where required
- ⇒ NH-9 models only – level machine using wind down jockey stand.

**⚠ Do not allow drop down leg to fall freely, as injury may occur.**

**⚠ Units with 4 drop down legs must be levelled using the jockey wheel.**

### Step 5



- ⇒ Release load binders or straps to lights.

### Step 6



### Start Generator - MS - Series

- ⇒ Turn key to 'HEAT' for 10 seconds (if < 10°C (50°F)).
- ⇒ Turn key to 'START' to start generator.

### NH – Series

- ⇒ Turn key to start. Press Green button. Start panel will glow automatically if required.

**⚠ Ensure Main Circuit Breaker/RCD is switched to “OFF” (if accessible).**

### Step 7 Raise Mast – MS-Series Hydraulic Masts



- ⇒ Raise Lighting Tower mast using toggle on control panel.

**⚠ Check and remove overhead obstructions before proceeding with mast raise.**

### MS-Series Manual Masts



- ⇒ Raise manual mast - pull down on counter balance handle to raise mast to vertical position.



- ⇒ Extend mast using winch.

### NH-Series

- ⇒ Fully extend the light tilt using the toggle on the control panel.
- ⇒ Adjust mast angle and height using the toggles on the control panel

### Step 8

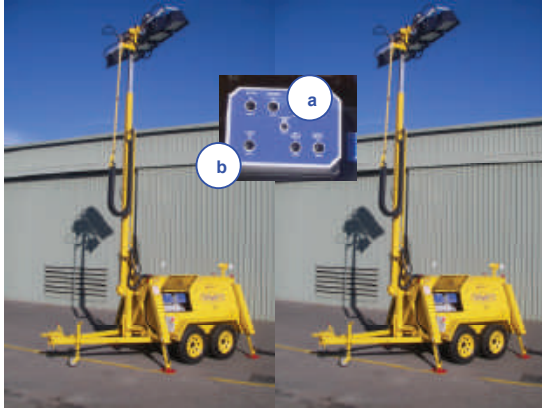

- ⇒ Position Lights.
- ⇒ (a) Extend mast using toggle on control panel.
- ⇒ (b) Adjust light tilt to suit, using toggle on control panel.
- ⚠ **Check and remove overhead obstructions before proceeding with mast extension and light tilt adjustment.**
- ⚠ **NH-9 Series: light tilt must be fully extended for all other hydraulic mast functions to operate. Refer to interlocking constraints in section 8.4.4.1**

### Step 9

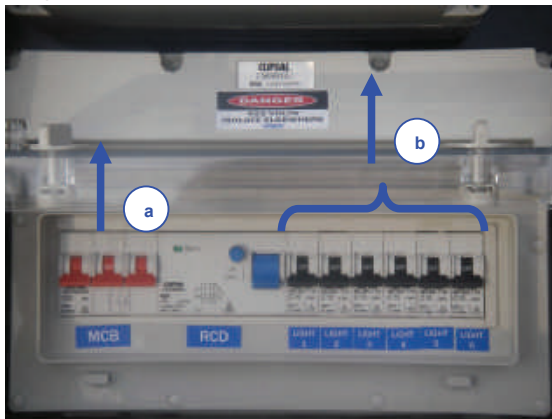

- ⇒ Illuminate lights.
- ⇒ (a) Switch MCB/RCD to "ON".
- ⇒ (b) Switch each light circuit breaker to "ON".
- ⇒ (c) Close cabin doors.
- ⚠ **Ensure Lights are greater than 8 meters from any operator or bystander.**

### Step 10 Manual Mast Rotation

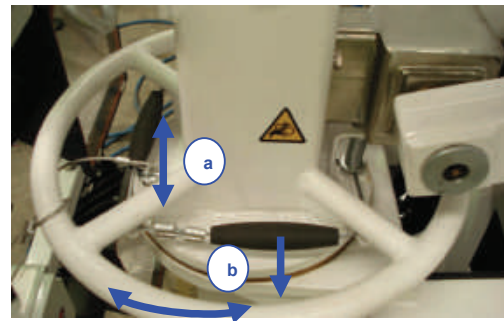
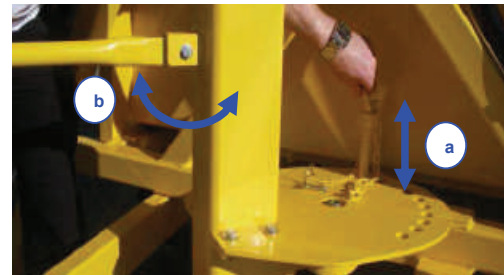

- (a) Remove retaining pin in swivel plate.
- ⇒ *MS-Series*: Rotate mast using handle.
- ⇒ *NH-Series*: Rotate mast use rotation ring, simultaneously pulling on cable.
- ⇒ Secure mast in position using retaining pin (refer item (a))

- ⚠ **Check and remove overhead obstructions before proceeding with mast extension and light tilt adjustment.**

### Step 11 Hydraulic Rotation

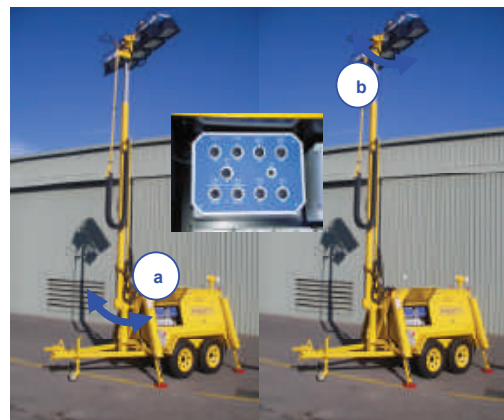

- ⇒ Rotate mast/light bar to required position – Hydraulic (if fitted).
- ⇒ Use marked toggles on control panel to rotate mast to required position.
- ⇒ Use marked toggle on control panel to rotate light bar to required position. (not available on *NH-Series*)

## 8.4.4 Shut-down Procedures – MS Series and HS Series

### Step 1

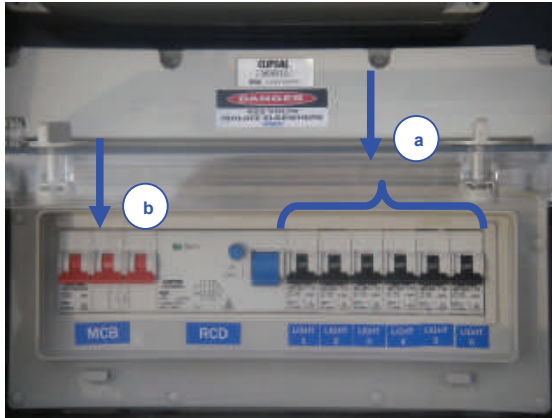

- ⇒ Extinguish lights.
- ⇒ (a) Switch each light circuit breaker to “OFF”.
- ⇒ (b) Switch MCB/RCD to “OFF”.

### Step 2



- ⇒ Stow Lights.
- ⇒ *NH-Series*: Ensure light tilt is fully extended.
- ⇒ (a) Retract mast using toggle on control panel.
- ⇒ (b) Adjust light tilt to downward position using toggle on control panel.

**⚠ Check and remove overhead obstructions before proceeding with mast extension and light tilt adjustment.**

### Step 3

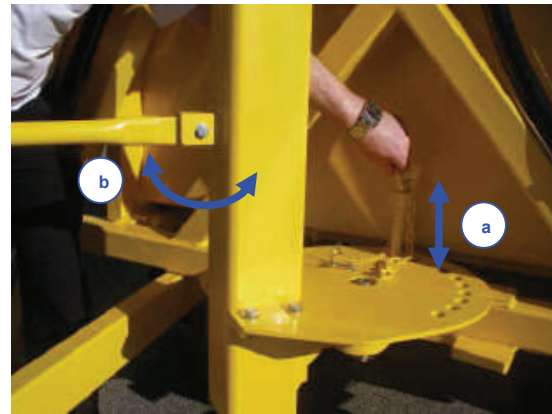

- ⇒ Rotate mast to centre position – manual.
- ⇒ (a) Remove retaining pin in swivel plate.
- ⇒ (b) *MS-Series*: Rotate mast using handle to the centreline.
- ⇒ (b) *NH-Series* : Rotate mast use rotation ring, simultaneously pulling on cable
- ⇒ (c) Secure mast in position using retaining pin (refer item (a)).

**⚠ Ensure retaining pin is in position.**

### Step 4

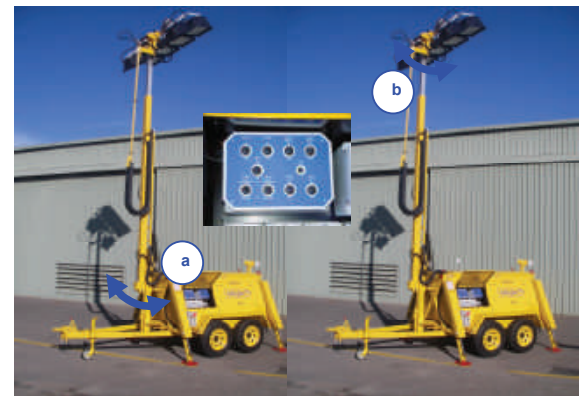

- ⇒ Rotate mast/light bar to central position – hydraulic (if fitted).
- ⇒ (a) Use marked toggles on control panel to rotate mast to central position.
- ⇒ (b) *MS-Series*: Use marked toggle on control panel to rotate light bar to central position.

**⚠ *NH-Series*: Ensure that the light tilt stays fully extended.**

### Step 5



- ⇒ Lower mast using toggle on control panel.
  - ⇒ *NH-Series*: Use marked toggles on control panel to fully retract the light bar.
- ⚠ Ensure that mast and light bar are rotated to centreline as per step 3.**



- ⇒ Lower manual mast - retract mast by using the winch.



- ⇒ Release retaining pin and lower mast into mast receiver.

### Step 6



- ⇒ Attach load binders or straps to lights and tighten.

### Step 7



- ⇒ Shut down generator.
- ⇒ (a) Turn key to 'OFF'.

### Step 8



- ⇒ Raise stabilizer legs – Drop-Down Legs.
- ⇒ (a) Pull out retaining spring pin, whilst supporting drop down leg.
- ⇒ (b) Raise leg into position.
- ⇒ Ensure spring catch is secure in locating hole.

**⚠ Do not allow drop down leg to fall freely, as injury may occur.**

### Step 9

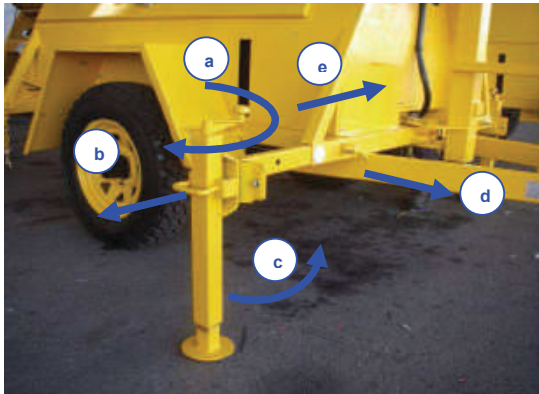

- ⇒ Raise stabilizer legs – Wind-Down Legs.
- ⇒ (a) Wind stabilizer legs up.
- ⇒ (b) Release rotation pin on stabilizer leg.
- ⇒ (c) Rotate stabilizer leg through 180°.
- ⇒ (d) Release outrigger retaining pin.
- ⇒ (e) Retract outrigger.

### Step 10



- ⇒ Raise stabilizer legs – Hydraulic Legs.
- ⇒ (a) Using marked toggles on hydraulic panel raise each leg individually until it is fully retracted.

### Step 11



- ⇒ Check battery isolator (if fitted) is turned to the "OFF" position. (Single pole shown)

### Step 12



- ⇒ Check emergency stop buttons are engaged (if fitted).

### Step 13

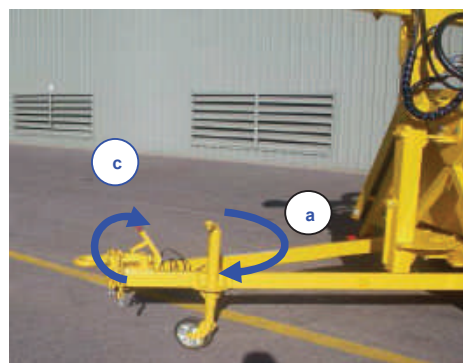

- ⇒ Attach trailer to towing vehicle.
- ⇒ (a) Raise trailer to towing vehicle using jockey wheel.
- ⇒ (b) Engage tow hitch to towing vehicle ball or pintle hook.
- ⇒ (c) Release handbrake.

**⚠ Please refer to Job Safety Analysis (JSA) in section 8.3 prior to towing.**

#### 8.4.4.1 NH 9 Series Interlocking Constraints

- ⇒ Light lilt must be fully extended before the post (raise/lower) or mast (extension/retraction) can be activated.
- ⇒ The mast must be fully retracted before the post (raise/lower) can be activated.



---

---

## 8.4.5 SETTING THE TIMER SHUT DOWN UNIT (IF FITTED)

**THEBEN TR611 TIMER SETTING INSTRUCTION FOR SHUTDOWN SYSTEM SETTING SHOWN WILL SHUT THE GENERATOR DOWN AT 6:30 AM AND BE READY TO START AGAIN AT 6:31 AM.** (This programming allows bottom timer contacts 2 and 3 which are normally closed to open for 1 minute between 6:30 and 6:31 to enable the unit to shutdown.)

### 8.4.5.1 SYSTEM SETTINGS

- To clear timer time settings
  - Press (NEW PROG appears)
  - Press (RESET)
  - Press until CLEAR appears
- To set language
  - Press Button
  - Press to get language
  - Press twice to select and CONFIRM (NEW PROG appears)
  - Press to select SINGLE or ALL
  - Press twice to select OR twice to install NEW PROGRAM
- To set date (current date)
  - Press until current year is shown
  - Press to set year
  - Press until current month is shown
  - Press to set month
  - Press until current day is shown
  - Press to set day
- To set time (current time)
  - Press until current hour is shown
  - Press to set hour
  - Press until current minute is shown
  - Press to set minute
- To clear ON time (shutdown time)
  - Press Button (PROGRAM appears)
  - Press (NEW PROG appears)
  - Press (TIME ON appears)
  - Press (HOUR appears)
  - Press to set hour at 6 AM
  - Press (MINUTE appears)
  - Press to set minute at 30
  - Press to set minute (MONDAY appears)
  - Press (COPY appears)
  - Press (ADD TU appears)
  - Press (ADD WE appears)
  - Keeping pressing to set all days (STORE appears)
  - Press (NEW PROG appears)
  - Press to exit OR twice to set OFF time

### 8.4.5.2 TO SET TIMER

- To clear ON/OFF program settings

Press Button (PROGRAM appears)

---

---

7. To set program OFF time (restart allowed time)

Press  Button (PROGRAM appears)

Press  (NEW PROG appears)



Press  (TIME ON appears)

Press  (TIME OFF appears)

Press  (HOUR appears)

Press   to hour at 6 AM

Press  (MINUTE appears)

Press   to set minute at 31

Press  to set minute (MONDAY appears)

Press  (COPY appears)

Press  (ADD TU appears)

Press  (ADD WE appears)

Notice the arrow head on bottom of screen  
Arrow head shows days of week, 1 is MONDAY

Keep pressing  to set all days (STORE appears)

Press  (NEW PROG appears)

Press  Button to set program and exit

#### 8.4.5.3 TO CHECK TIMER

8. To check program times

Press  Button to bring up screen

Press  (PROGRAM appears)

Press  Button (NEW PROG appears)

Press  until CHECK appears

Press  (MONDAY appears)

Press  (NEXT and OFF time appear)

Press  (NEXT and ON time appears)

Press  and scroll through settings

Notice the arrow head on bottom of screen  
Arrow head shows days of week, 1 is MONDAY

When END appears press 

Timer is ready to use.

#### 8.4.5.4 TIMER MANUAL TEST

9. To check lower shutdown

Press  Button until MANUAL appears

Press  Button (OVERIDE, On and flashing hand appears)

Press  Button (OVERIDE, On and steady hand appears)

Engine should shutdown

Press  Button until MANUAL appears

Press  Button (Clear, On and flashing hand appears)

Press  Button (DATE, OFF and time appears)

END OF TEST

## 8.5 FAULT DIAGNOSIS

In the event of difficulty in operating your Allight Generator and Lighting Tower, consult the table below. If the difficulty persists or is not a listed item, then contact your service and maintenance provider.

Symptom	Possible Remedy
Engine not starting.	<ul style="list-style-type: none"> <li>• Check battery isolator is in ON position.</li> <li>• Ensure Emergency Stop (if fitted) is not engaged.</li> <li>• Check battery is charged. Charge or replace as required.</li> <li>• Check sufficient fuel in tank.</li> <li>• If ambient temperature is below 5 C, turn key to pre-heat before starting.</li> <li>• Check fuel tank for water contamination.</li> <li>• If tank has previously been emptied, prime by pumping fuel bulb</li> <li>• Check tower is level.</li> </ul>
Engine Shutting Down.	<ul style="list-style-type: none"> <li>• Check Engine fluid levels.</li> <li>⚠ <b>Engine and alternator will be very hot after running. Allow to cool before checking fluid levels.</b></li> <li>• Check sufficient fuel in tank.</li> </ul>
Lights Turning off.	<ul style="list-style-type: none"> <li>• Check Shut down timer settings (if fitted).</li> </ul>
Circuit Breakers Trip.	<ul style="list-style-type: none"> <li>• Turn engine off. Visually check for damaged cables. If no damage apparent, reset circuit breakers. Follow start up procedure.</li> <li>⚠ <b>If fault persists after resetting, do not operate tower and call for service.</b></li> </ul>
All Lights fail to illuminate on start.	<ul style="list-style-type: none"> <li>• Check Main circuit breaker is on.</li> <li>• Check all circuit breakers are on.</li> <li>• Lamps have been allowed to cool since last operation (15 mins).</li> </ul>
Individual Lamps Fail to Illuminate.	<ul style="list-style-type: none"> <li>• Lamps have been allowed to cool since last operation (15 mins).</li> <li>• Circuit breakers are on.</li> <li>• Check lamp condition and replace if necessary.</li> <li>⚠ <b>Light assemblies may be hot. Allow to cool completely before touching (15 mins).</b></li> </ul>
Hydraulic Pump and Motor does not Operate.	<ul style="list-style-type: none"> <li>• Check battery isolator is in ON position.</li> <li>• Ensure Emergency Stop (if fitted) is not engaged.</li> <li>• Check Engine is running.</li> <li>• Check circuit breaker on hydraulic panel is on.</li> </ul>

---

---

## A. REPORTING SAFETY DEFECTS

*United States and Canada ONLY.*

If you believe that your vehicle has a defect that could cause a crash or could cause injury or death, you should immediately inform the National Highway Traffic Safety Administration (NHTSA) in addition to notifying Allight Pty Ltd.

If NHTSA receives similar complaints, it may open an investigation, and if it finds that a safety defect exists in a group of vehicles, it may order a recall and remedy campaign. However, HHTSA cannot become involved in individual problems between you, your dealer, or Allight Pty Ltd.

To contact NHTSA, you may either call the Vehicle Safety Hotline toll-free at 1-88-327-4236 (TTY: 1-800-424-9153), go to <http://www.safercar.gov>; or write to:

Administrator  
NHTSA  
400 7<sup>th</sup> Street SW  
Washington, DC 20590

You can also obtain other information about motor vehicle safety from <http://www.safercar.gov>.

California  
Proposition 65 Warning

Diesel engine exhaust and some of its constituents are known to the State of California to cause cancer, birth defects, and other reproductive harm.

---

---

## B. PRE-START CHECKS

1. Check filter service is up to date (150-200 hours). If changing, write last service hours on filter.
2. Check engine oil level.
3. Check radiator coolant.
4. Check hydraulics fluid level.
5. Check machine for damage.
6. Check for leaks.
7. Visually inspect wire cable for damage.
8. Ensure lenses are clean. Do not touch the lamp itself. Wash lamp with spirits if touched.
9. Check operation of all machine functions.

 **NOTE: Any issues found in checks 1-8 must be rectified by a qualified tradesperson before performing check number 9. If the machine fails any checks, follow site procedures for tagging the machine “OUT OF SERVICE” and call for service.**



Allight Pty Ltd  
12 Hoskins Road  
Landsdale, Perth, WA 6065

**Tel: +61 8 9302 7000**  
**Fax: +61 8 9302 7001**

