

No. 3498-35900-0

▲ Read this handbook thoroughly and understand the whole information contained before trying to operate, inspect and service your machine!

**OPERATING &  
MAINTENANCE  
INSTRUCTIONS**

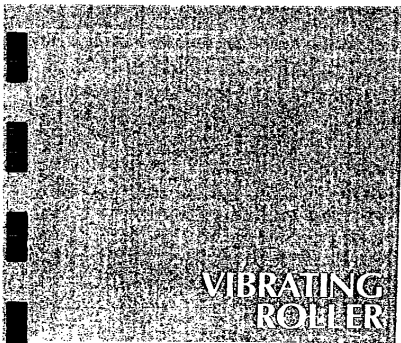

MODEL  
**GW750-2**

From 1GW2 - 20101

**SAKAI®**

## PREFACE

This operator's manual serves as a guide for the use of your Sakai GW750-2 Vibrating Roller for those who are new to the machine, and also for the people who have experience in using the Machine and want to refresh their knowledge for the machine.

Read this manual thoroughly and try to fully understand the information before operating your machine. Keep this handbook at hand whenever you do your work.

The main subjects of this manual are:

(1) Basic precautions for safety, (2) Operation, (3) Daily maintenance and (4) Specifications. For operation and maintenance of the engine, refer to the Engine Instruction Manual furnished separately. Descriptions in this manual can differ from the machine instructions of your machine due to the results of the investigation and improvement in its design. If you have any inquiry regarding your Machine or this manual, contact our distributors.

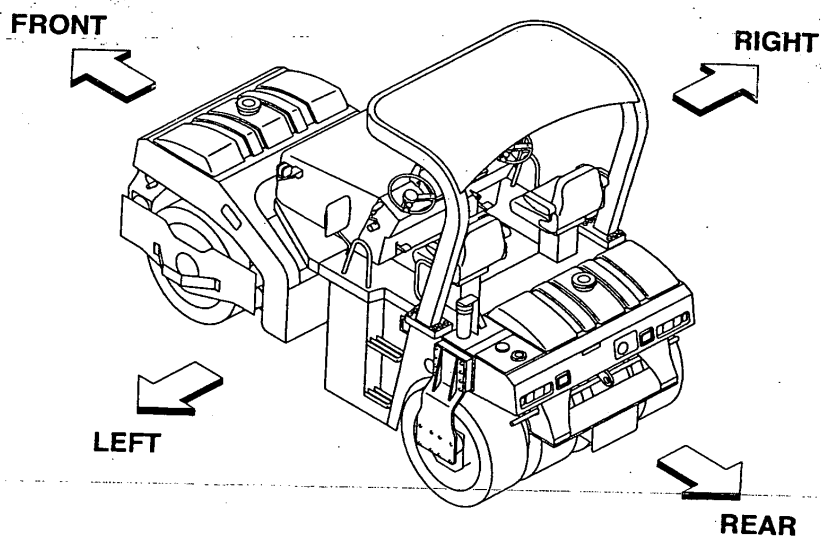

## CONTENTS

### CONTENTS

#### PREFACE

MACHINE AND ENGINE IDENTIFICATION NUMBERS.....	1
SAFETY NOTICES.....	2

1. BASIC PRECAUTIONS FOR SAFETY .....	4
1.1 General Precautions .....	4
1.2 Preparation for Safe Operation .....	6
1.3 Before Starting the Engine.....	7
1.4 After Starting the Engine.....	8
1.5 During operation .....	8
1.6 Loading and Unloading.....	10
1.7 Transportation .....	11
1.8 Handling the Battery .....	11
1.9 Towing.....	12
1.10 Before Servicing .....	13
1.11 During Servicing .....	14
1.12 Safety Decals.....	16
2. OPERATION .....	18
2.1 Instruments and Controls.....	18
2.1.1 Operator's station .....	18
2.1.2 Gauges, indicator lamps and warning lamps .....	19
2.1.3 Switches.....	21
2.1.4 Operating levers and pedals .....	25
2.1.5 Unloader valve .....	27
2.1.6 Fuse box.....	27
2.2 Handling and Adjustments .....	28
2.2.1 Seat adjustment .....	28
2.2.2 Disengaging the brake when towing .....	28
2.3 Operation .....	29
2.3.1 Before-starting inspection .....	29
2.3.2 Starting the engine .....	30
2.3.3 After starting the engine .....	31
2.3.4 Traveling .....	32
2.3.5 Stopping / Parking .....	33
2.3.6 Stopping the Engine.....	34
2.3.7 Check after Stopping the Engine.....	34
2.4 Vibratory Operation.....	35

2.5	Sprinkler / Changeover valve .....	35
2.6	Liquid Sprayer .....	39
2.7	Precautions for Work .....	41
2.7.1	Compaction operation .....	41
2.7.2	When going downhill .....	41
2.7.3	On a slope .....	41
2.8	Applicable Jobs .....	42
2.9	After Operation .....	42
2.10	Loading and Unloading .....	43
2.10.1	Use of a trailer equipped with a winch .....	43
2.10.2	Self-propelling .....	44
2.11	After Loading the Machine .....	45
2.12	Transportation .....	45
2.13	Operation in Cold Weather .....	45
2.13.1	Fuel oil and grease .....	45
2.13.2	Coolant .....	46
2.13.3	Battery .....	47
2.14	When the Cold Season is Over .....	48
2.15	For a Long Storage Period .....	48
2.16	During the Storage Period .....	48
2.17	When the Battery Has Discharged .....	49
2.17.1	Connection and disconnection of booster cables .....	49
3.	PERIODICAL MAINTENANCE .....	51
3.1	Precautions .....	51
3.2	Walk-Around Checking .....	53
3.3	Periodical Maintenance Points .....	54
3.4	Maintenance Procedure .....	56
(1)	Every 10 hours or daily .....	56
(2)	Every 50 hours .....	57
(3)	Every 250 hours .....	58
(4)	Every 500 hours .....	62
(5)	Every 1000 hours .....	63
(6)	As required .....	65
3.5	Feeding Water and Lubricants .....	67
3.6	Electric Wiring Diagram .....	69
4.	SPECIFICATIONS .....	71

## MACHINE AND ENGINE IDENTIFICATION NUMBERS

### MACHINE AND ENGINE IDENTIFICATION NUMBERS

When ordering parts or making inquiries about your machine, the following information is requested:

**(1) Machine model**

Indicated on the dashboard in the operator's station.

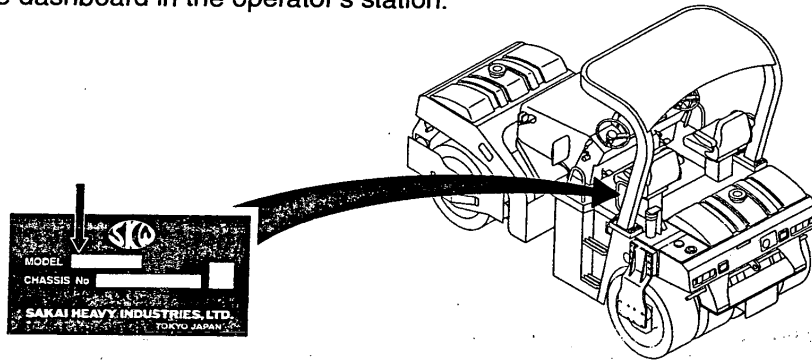

**(2) Machine serial number**

GW750 - 2 ⇨ 1GW2 - ○○○○○

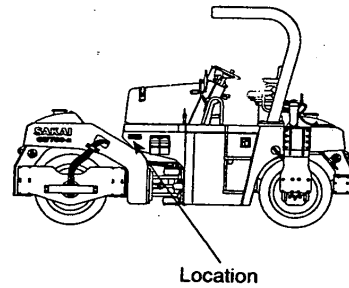

**(3) Engine serial number**

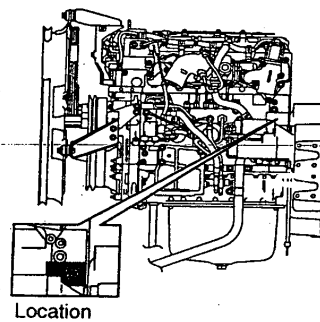

## **SAFETY NOTICES**

### **SAFETY NOTICES**

For the safe use of your machine, correct handling and periodical maintenance are of utmost importance. Thoroughly read the safety precautions described in this manual. Do not attempt to operate and maintain your machine until you gain a full understanding of these safety statements.

This manual covers the proper and safe method of driving and handling of this machine for its intended use. When this machine is used a manner, other than that covered in this manual, you must assume responsibility for your own personal safety.

In this manual and on the machine, you will find safety notices. Each safety notice starts with a signal word as shown below:

 **DANGER**

Denotes that there is an extreme hazard. If you fail to take proper precautions, it is highly likely that you could be killed or seriously injured (The color of the symbol  is red).

 **WARNING**

Denotes that there is a hazard. If you fail to take proper precautions, you could be killed or seriously injured (Symbol  is orange).

 **CAUTION**

Calls attention to safety practices. If you fail to take proper precautions, you could be injured or cause damage to the machine (Symbol  is yellow).

**SAFETY NOTICES**

It is almost impossible for the safety notices in this manual and or the machine to cover all the potential dangers. Keep alert to possible dangers not mentioned in this manual and on the decals.

**WARNING**

**Do not operate your machine before you read its operator's manual thoroughly.  
Incorrect operation can kill or cause injury.  
It is your responsibility to operate the machine safely.**

- ☆ Non-approved modifications can pose safety-related problems. Before making any modifications, consult your distributor. For an injury or damage to the machine caused by non-approved modifications, Sakai accepts no responsibility.
- ☆ Basic precautions for safe operation of your machine are discussed beginning on page 4.
- ☆ To operate and work with your machine, you must be qualified.

▲ **WARNING:** Negligence of these instructions can lead to accidents.

## 1. BASIC PRECAUTIONS FOR SAFETY

### 1. BASIC PRECAUTIONS FOR SAFETY

#### 1.1 General Precautions

■ **Read thoroughly the operator's manual.**

- Understand the functions of the controls and gauges. Familiarize yourself with their location and how to operate them. Understand the meaning of all the symbols.



■ **Obey the worksite rules.**

- Follow the worksite rules such as matters forbidden or to be attended to, and working procedures.

■ **Wear protective clothing to suit the work.**

- Wear clothing, safety shoes and hard hat to suit your work.
- Do not wear clothing and accessories that tend to get caught in the controls or protruded portions of the machine. Do not wear oily clothing.
- According to the type of jobs, wear safety goggles or mask.



■ **Know the work area in advance.**

- Know the terrain, geology and conditions of the road surface at the worksite. Start working after securing safety such as stationing a guardsman or putting up barriers where there is a risk of falling of the machine or collapse of shoulder.

■ **Provide against an accident.**

- Decide in advance the means of communication in an emergency. Know the location and use of an extinguisher and first-aid kit.

■ **Know the capability of the machine.**

- Thoroughly understand the performance of your machine and correctly operate the machine to meet the requirements of the job site. Operating the machine beyond its capabilities may lead to an accident. Use your machine within its capability.

ts.

▲ **WARNING:** Negligence of these instructions can lead to accidents.

## 1. BASIC PRECAUTIONS FOR SAFETY

### ■ Do not use a machine which has not been serviced correctly at regular intervals.

- Before working, perform necessary inspections. Start operation only after making certain the machine is in good operating condition. If found to be abnormal, report to the responsible person and have the fault corrected. Operate the machine after making sure that it is safe to operate.

### ■ Do not allow anyone to enter the work area except for authorized personnel.

- Always conduct the work paying attention to the workers around the machine.



### ■ Be careful of hot parts.

- After your machine has operated for some time, the coolant, engine oil and hydraulic fluid will become hot and the pressure will build up. If, in this state, you try to remove the filler caps, drain the oil or replace the filters, you can get burned. Perform this work in accordance with the correct procedures with the machine cooled down.
- To remove the radiator cap, slowly loosen the cap to relieve the pressure with the engine shut down and the coolant cooled down. (For the radiator cap with a lever, lift the lever to release the trapped pressure.)
- When removing the filler cap on the hydraulic tank, release the trapped pressure by turning it out slowly to prevent the oil from gushing out.
- Do not touch the muffler while the engine is running or immediately after it has been shut down. You can get burned.



### ■ Be careful with fire.

- The fuel, oil, and anti-freeze will catch fire if open flames or ignition sources are used close to them. Particularly, the fuel is highly flammable.



- Do not smoke or use a match or cigarette lighter close to inflammables (combustibles).
- When refueling, stop the engine and do not smoke.
- The filler caps of the fuel and oil tanks must be kept tight.



▲ **WARNING:** Negligence of these instructions can lead to accidents

## 1. BASIC PRECAUTIONS FOR SAFETY

### ■ **Mount on or dismount from your machine after it has come to a complete stop.**

- For getting on and off, face the machine and use the handrail and step.
- Do not jump on or off a machine, particularly when it is moving.

### ■ **To handle the hydraulic fluid.**

- Wear safety goggles to protect your eyes from contact with hydraulic fluid. It can irritate your eyes.  
If the fluid contacts your eyes, flush with clean water for 15 minutes and get medical aid.
- The fluid can also irritate your skin. When handling it, wear rubber gloves to avoid contact with it. In case of skin contact, wash with soap and water.
- Be careful not to swallow the fluid. It can cause diarrhea and emesis.  
If swallowed, do not try to vomit. Get medical help immediately.



## 1.2 Preparation for Safe Operation

### ■ **Clean the step, operator's station and floor board.**

- Do not place parts, tools or unnecessary articles on the step, operator's station and floor board.
- Keep the step, floor board, controls and handholds free from muds, oil, ice or water, as they can cause slippage. Repair them if found to be damaged. Tighten loose bolts.
- Keep your boot soles free of oil or muds. They can slip, leading to an accident.

### ■ **Inspect your machine before operation**

- Check your machine for damage such as cracks and deformation. If found to be abnormal, operate the machine after taking a proper measure to secure safety.
- Check the level of fluids (fuel, engine oil, coolant, anti-freeze and hydraulic oil). Add as necessary.
- Check the area where the machine has parked for signs of leakage of oil, fuel and water. If any leakage is noticeable, determine the cause and make corrections immediately.



▲ **WARNING:** Negligence of these instructions can lead to accidents.

## 1. BASIC PRECAUTIONS FOR SAFETY

### ■ **Pay attention to ventilation.**

- Exhaust fumes are dangerous if breathed in. When starting the engine in an enclosed area, provide good ventilation with windows and doors opened.

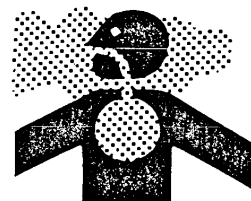

### ■ **Do not stand close to the exhaust gas pipe opening.**

- Exhaust fumes are noxious if breathed in.

## 1.4 After Starting the Engine

### ■ **Secure safety around the machine.**

- Ensure that the area around the machine is clear of personnel and obstructions. Pay particular attention to dead spaces. Before starting, sound the horn.



### ■ **Warm up the Engine**

- Do not put your machine into motion immediately after the engine has started, let it idle for several minutes until it is at operating temperature.
- Check the area where the machine has parked for signs of leakage or oil, fuel and water. If any leakage is noticeable, determine the cause and make corrections immediately.

### ■ **Have a trial run.**

- Make a test run in a safe place to check that there are no abnormal signs. If found to be abnormal, rectify the fault before traveling again.
- Listen for unusual sounds, and check for abnormal temperature rise. If abnormal, park the machine in a safe location and find the source of trouble before operating.

## 1.5 During Operation

### ■ **No other person but the operator**

- This machine is a one-man roller. Do not allow anyone to get on. Only the operator is allowed on this machine while it is running or in operation. Radios are not permitted.

### ■ **Before mounting, be sure areas around the machine are safe.**

- Before getting on the machine, make certain that there are no obstacles around the machine and no workers under it. If some workers are present or close to the machine, tell them that the machine is about to move, warning them to stay away from it.

ts.  
▲ **WARNING:** Negligence of these instructions can lead to accidents.

1. **BASIC PRECAUTIONS FOR SAFETY**

■ **Do not try to get on or off a moving machine.**

- Get on or off the machine after making sure it has come to a complete stop.

■ **To go uphill or downhill, run at low speeds. Do not attempt to shift speeds while traveling on a grade.**

- Shifting speeds on a slope can cause unexpected running down the slope.
- Going down hill at speeds other than low range can cause the machine to run down violently.

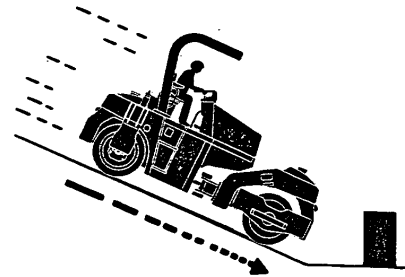

■ **Refrain from inattentive driving.**

- Inattentive driving or driving relying on guess work can cause an accident. Use extreme care for workers present in the path of the roller or around it. In case of danger, stop and sound the horn, and proceed when the area is clear of personnel or obstructions.

■ **When changing the direction of travel, secure the safety on the path in the travel direction.**

■ **Keep everyone away from the pinch points.**

- When making turns, do not allow anyone to come close to the pinch point.



s  
■ **At night, carefully drive the machine.**

- Nighttime driving tends to frustrate the sense of distance. Carefully drive the machine at a speed suited to illumination. Keep the headlamps and flood lamps lighted. If necessary, provide extra lighting in the work area.

ll  
■ **Repair as soon as possible if found to be defective.**

- If the machine is found to be faulty, stop the machine and repair. Do not operate the machine until the problem is corrected. When any warning lamp indicates faulty operation, inspect the machine after moving it to the nearest safe location.

**⚠ WARNING:** Negligence of these instructions can lead to accidents.

### 1. BASIC PRECAUTIONS FOR SAFETY

- Do not operate the machine except from the operator's seat. Do not drive in a standing posture.
- While making turns, do not run at abnormally high speed and do not turn the steering wheel abruptly and sharply.
- For the traveling on structures such as a bridge, make certain that they can support your machine. Before traveling on the structure, you must know the load capacity of the structure and the load weight of the machine you are operating to insure safe travel across the structure.
- Do not make turns on a slope and do not travel across sidehill. If necessary to do so, go down straight along the slope to the flat ground, move sideways and go up straight to the destination.

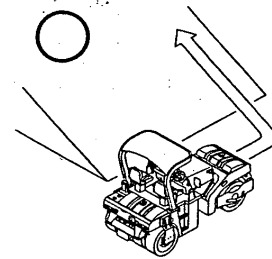
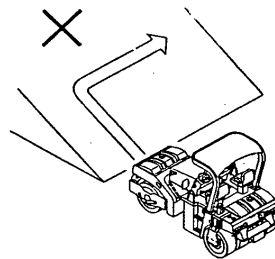

#### ■ When parking.

- Select level and hard ground. If necessary to park on a slope, block the front of the drums on the downside of the slope.
- When required to park on the public road, provide necessary markings such as flag, barriers and illumination. However, be sure they do not obstruct traffic.
- When getting off the machine, stop the engine and remove the key from the ignition switch.

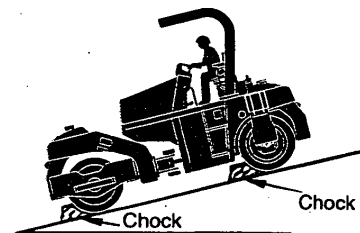

### 1.6 Loading and Unloading

- Loading and unloading can accompany any danger. Use extreme care.
- Select level and hard ground leaving a sufficient distance from the shoulder.
- Use sturdy ramps with proper width, length and thickness which allow safe loading and unloading. If they deflect considerably under load, apply wooden blocks to reinforce the ramps.

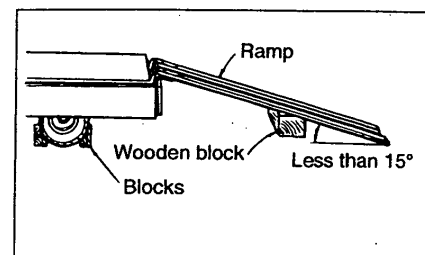

**WARNING:** Negligence of these instructions can lead to accidents.

### 1. BASIC PRECAUTIONS FOR SAFETY

- To prevent your machine from crosswise slippage, keep the ramps free from oil, mud, debris, etc. The drum must also be free from extraneous matter that can cause slippage.
- Do not steer your machine on the ramps. If the machine is facing in the wrong direction, allow it to dismount from the ramps, correct the direction and try again.
- Do not use kinked, twisted or damaged wireropes for crane or winch operation. Use ones with ample strength.
- When loading is complete, fix the machine with wooden blocks placed under the drums and chains fastened to the machine.

### 1.7 Transportation

- Follow required regulations.
- Select a transporting route according to the overall width, overall height and gross weight of the trailer with the roller loaded.

### 1.8 Handling the Battery

When handling the battery:

- Battery electrolyte contains sulphuric acid. It will destroy clothing and skin. If it touches your clothing or skin, flush with large quantities of water.
- In case of eye contact, flush with clean water and seek medical help.
- If swallowed, drink large amount of water, milk, beaten egg or vegetable oil, and get medical help.
- Wear safety goggles when handling the battery. Wear safety goggles, full face shield, rubber gloves and rubber apron when adding fluids to the battery.
- The battery generates flammable gases that can cause an explosion. Do not smoke close to the battery. Keep the battery away from flames, sparks and ignition sources.



▲ **WARNING:** Negligence of these instructions can lead to accidents.

## 1. BASIC PRECAUTIONS FOR SAFETY

- Inspect or handle the battery with the engine shut down and the starter key in the OFF position.
- Keep metallic items such as tools away from the battery terminals.
- Loose terminals can cause sparks leading to an explosion. Secure the terminals tightly.

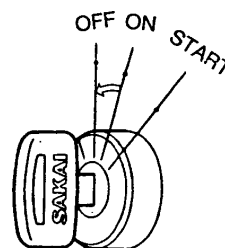

### ■ Jump-starting the engine.

- Wear safety goggles when jump-starting the machine.
- When starting from another machine, do not allow the two machines to make contact with each other.
- When connecting the battery cables, start with the positive terminal. For disconnection, start with the negative one.
- Do not allow a tool to bridge between the positive terminal and machine body. This can generate dangerous sparks.
- Do not connect the booster cable to wrong terminal. NEVER connect the positive terminal to the negative.
- Final connection to the engine block of the disabled machine can cause sparks. The connecting point should be as far as possible from the battery.

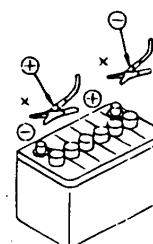

## 1.9 Towing

- To tow the machine, use wire ropes with ample strength.
- Do not perform towing on a slope.
- Do not use towing ropes twisted, kinked or damaged.
- Do not stride towing cables.
- Keep everyone away from the space between the machine and the towing vehicle when connecting the two.
- Align the connecting portions of the machine and towing vehicle straight when coupling the machine.

▲ **WARNING:** Negligence of these instructions can lead to accidents.

## 1. BASIC PRECAUTIONS FOR SAFETY

### 1.10 Before Servicing

■ **Attach warning tags when servicing the machine.**

- Serious accidents can occur if the machine is unexpectedly started or controls carelessly touched by an unauthorized person.
- Attach a warning tag at a clearly visible location in the operator's station and insure the key has been removed from the ignition switch.



■ **Use proper tools.**

- It is very dangerous to use damaged or deteriorated tools or to use tools for other purposes than intended. Use correct tools for their intended use only.



■ **Change safety-related parts at regular intervals.**

- Replace fuel hose and high pressure hydraulic hoses regularly to prevent fire. Replace high pressure hoses of the power steering system every two years.
  - ☆ Change these parts at regular intervals even if found to be normal. They will deteriorate as time goes on.
  - ☆ Change any hose found to be abnormal even if it is within its recommended service interval.

■ **Inspect or service your machine with the engine stopped.**

- If required to keep the engine running in such a case as radiator interior cleaning, perform the work with two persons. One of them should sit on the operator's seat getting ready for shutting down the engine. He must take care not to touch any of controls carelessly. Maintenance personnel must exercise extreme caution not to make contact with moving parts.

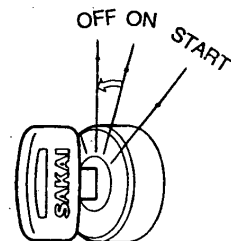

▲ **WARNING:** Negligence of these instructions can lead to accidents.

## 1. BASIC PRECAUTIONS FOR SAFETY

### ■ **Supplying fuel and oils**

- Spilled fuel or oil will be slippery. Wipe up immediately. Keep the filler caps tight. Do not use fuel for flushing oil. Handle fuel and oil in a well ventilated area.

### ■ **Check the coolant level in the radiator.**

- To check the coolant level, shut down the engine and allow the engine and radiator to cool down.

### ■ **Illumination**

- For inspecting the level of the fuel, oil, coolant and battery electrolyte, use burn-proof illuminations. Failure to use this type of illumination can result in an explosion.



## 1.11 During servicing

### ■ **Keep unauthorized persons away**

- During service, do not allow persons not concerned to enter the work area, particularly when grinding or welding operation is performed or heavy hammers are being used.



### ■ **Keep your machine clean**

- Spilled oil, grease or scattered debris are dangerous. Always keep your machine clean. Moisture that penetrates into the electrical system can cause malfunctions. Do not use water to clean sensors, connectors and the operator's station.

### ■ **When repairing the electrical system**

- For repairing the electrical system or for conducting welding, disconnect the negative cable from the battery to shut off the electricity.

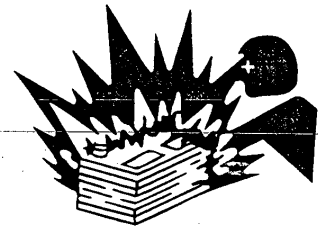

### ■ **Carefully handle high pressure hoses.**

- Do not try to bend or hit hoses against a hard object. Do not use hoses or pipes that are bent or damaged. They will burst.
- Replace damaged fuel hose and hydraulic hoses. An oil or hydraulic fluid spill can cause a fire.



**⚠ WARNING:** Negligence of these instructions can lead to accidents.

**1. BASIC PRECAUTIONS FOR SAFETY**

**1.12 Safety Decals**

Keep all decals clean. If lost, replace with new one. There are decals other than those shown below: Treat them in the same manner as the one shown here.

① 3998-16504-0

**⚠ WARNING**

**1. When Handling the Machine:**  
 - Operate only while seated.  
 - Use the handrails and steps when boarding and getting off.  
 - Never carry passengers.  
 - Never attempt to board or get off the machine while it is moving.

**2. Preparation for Safe Operation**  
 - Clean the steps, operator's station and floorboards.  
 - Obey the worksite rules.  
 - Sakai accepts no responsibility for any injury or damage to the machine caused by unapproved modification.  
 - Do not use a machine which needs repair or maintenance.  
 - Sound the horn immediately prior to starting the engine to warn people in the vicinity.

**3. Starting the Engine**  
 - Check that all operating levers are in the neutral position.  
 - Idle the engine for about 5 minutes to warm it up prior to commencing work.

**4. Parking Precautions**  
 - When parking the machine, park it on level ground, set the parking switch and set the roller chocks.  
 - Allow the engine to cool off by running it for about 5 minutes before stopping.  
 - When getting off the machine, remove the key from the ignition switch.

② 3998-16499-0 (2 locations)

**⚠ WARNING**



- Do not open the hood with the engine running.  
 - Contact with hot parts will cause burns.  
 - Contact with rotating parts will cause severe injury.

③ 3998-16500-0 (2 locations)

**⚠ WARNING**



- Avoid inhalation of exhaust gas.  
 - Avoid contact with exhaust pipe while engine is running and after it has been stopped. Contact with hot exhaust pipe will cause burns.

④ 3998-16489-0

**CALIFORNIA**  
 Proposition 65 Warning  
 Diesel engine and some of its constituents are known to the State of California to cause cancer, birth defects, and other reproductive harm.

⑤ 3998-16497-1

**⚠ WARNING**

- Thoroughly read the operator's manual before using the machine.  
 - Incorrect operation can cause severe injury or death.  
 - It is your responsibility to operate the machine safely.

⑥ 3998-16502-0

**⚠ DANGER**



- Do not approach, or allow objects to touch the rotating parts.  
 - Body parts which make contact with rotating mechanism will be severed.



- Do not open the radiator cap when fluid is hot.  
 - Radiator fluid is flammable. Avoid exposure to flame when radiator cap has been removed.



- Avoid contact with machine parts in the vicinity of the engine while engine is running and after it has been stopped. Contact with hot part will cause burns.

⑦ 3998-16505-0

**⚠ DANGER**

**Roll Over Prevention**  
 - Do not work in the vicinity of overhanging banks, or on grades steep enough to cause the machine to slide or roll over.  
 - Reduce speed prior to making turns.  
 - Pay particular attention when operating on uneven surfaces, as the machine may become unstable.

⑧ 3998-36002-0 (2 locations)



⑨ 3998-16501-0

**⚠ DANGER**



**Be Careful with Fire**  
 - When refueling, stop the engine and do not smoke.  
 - The filter cap of the fuel tank must be kept tight.

⑩ 3998-16511-0

**⚠ WARNING**

Replace the power steering high pressure hoses every two years.

⑪ 3998-06139-0



⑫ 1557-19006-1

**VIBRATOR OIL CAPACITY**  
 3.5 liters (0.9gallons)

ESSO. GEAR GP90  
 SHELL. SPIRAX 90ED  
 MOBIL. PEGASUS GEAR90

⑬ 3998-16559-0

**DANGER EXPLOSIVE GASES**  
 Cigarettes, lamps or sparks could cause battery to explode. Always shield eyes and face from battery. Do not charge or use broken, dented or equal poor connections without proper instruction and training.  
**KEEP VENT CAPS TIGHT AND LEVEL**  
**POISON CAUSES SEVERE BURNS**  
 Corrosive mixture. Avoid contact with skin, eyes or clothing. In event of accident flush with water and call a physician immediately.  
**KEEP OUT OF REACH OF CHILDREN**

⑭ 1557-19010-0 (2 locations)

**VIBRATOR OIL CAPACITY**  
 2.5 liters (0.66gallons)

ESSO. GEAR GP90  
 SHELL. SPIRAX 90ED  
 MOBIL. PEGASUS GEAR90

⑮ 1539-19003-0

**⚠ CAUTION**

Do not sprinkle water on electrical equipment because it causes the breakdown.

⑯ 3998-16619-0

**⚠ WARNING**

- The brake pedal is for the emergency.  
 - Please don't use it when you run usually.  
 - Please note that there is a possibility that the running motor damages when the brake pedal is excessively used.

⑰ 1539-19005-0

**⚠ CAUTION**

Check for over inflation. If bulges are noted change the tire at once.

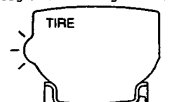

nts.

**⚠ WARNING: Negligence of these instructions can lead to accidents.**

**1. BASIC PRECAUTIONS FOR SAFETY**

ose

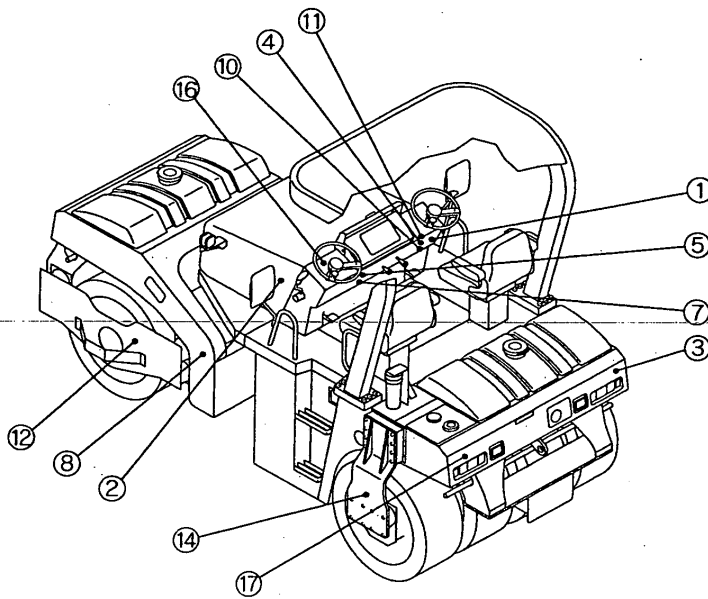
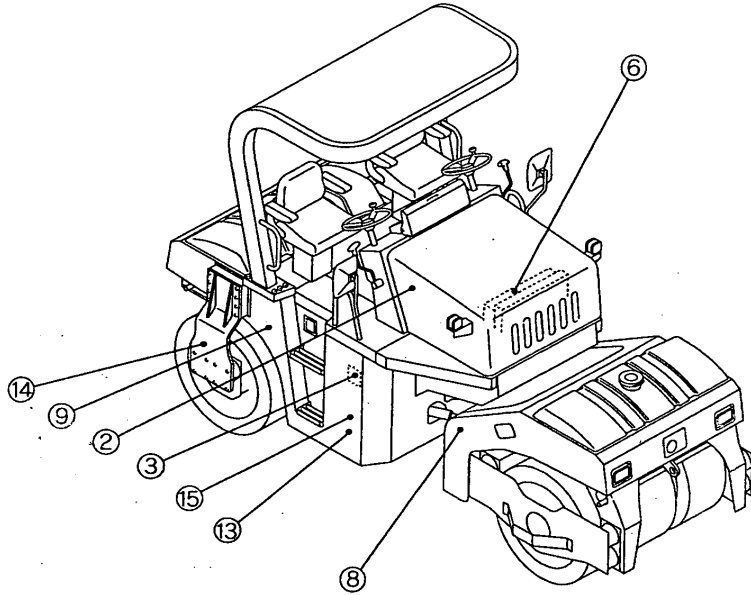

ent

ity,  
ally,  
ility

## 2. OPERATION

### 2. OPERATION

#### 2.1 Instruments and Controls

##### 2.1.1 Operator's station

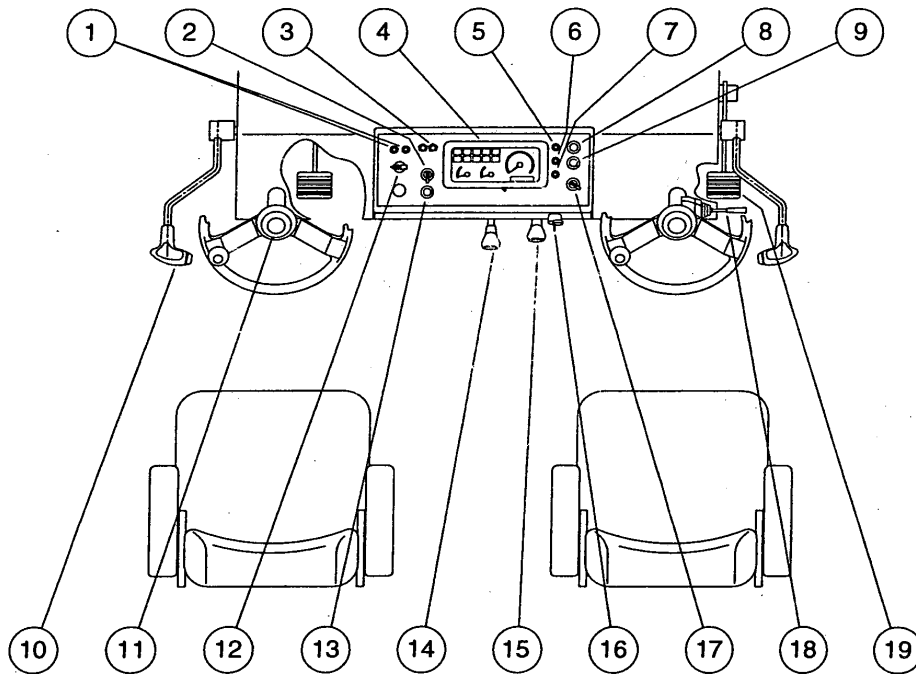

- |   |                       |
|---|-----------------------|
| ① Vibration indicator lamp                                  | ⑪ Horn switch         |
| ② Sprinkler switch  | ⑫ Vibrator switch     |
| ③ Sprinkler timer   | ⑬ Liquid spray switch |
| ④ Combination meter   | ⑭ Throttle lever      |
| ⑤ Engine check lamp   | ⑮ Speed shift lever   |
| ⑥ Boost temperature lamp                                    | ⑯ Starter switch      |
| ⑦ Overheat lamp   | ⑰ Lamp switch         |
| ⑧ Parking brake switch                                      | ⑱ Turn signal lever   |
| ⑨ Flood lamp switch   |                       |
| ⑩ Forward-Reverse lever (F-R lever)<br>with vibrator switch | ⑲ Brake pedal         |

2.1.2 Gauges, indicator lamps and warning lamps

For safe execution of your job, fully understand the role and function of the systems involved.

Combination meter

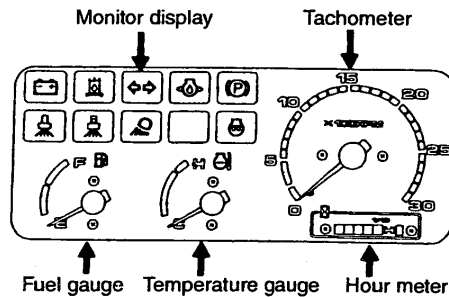

Tachometer / Hour meter

Indicates the engine RPM. The hour meter shows total operating hours. The service interval recommendation in this manual should be based upon the hour meter readings.

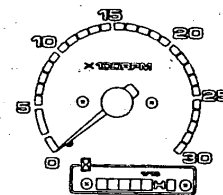

Tachometer/Hour meter

Temperature gauge

Indicates the coolant temperature. Zone close to symbol H indicates overheating. In case of overheating, run the engine at idling for about ten minutes before shutting it down. Then determine the cause.

The engine has been overheated also when the overheat lamp comes on. Stop the engine and look into the cause.

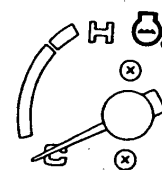

Temperature gauge

Fuel gauge

Indicates the fuel level in the tank.

E: The tank is empty.

F: The tank is full.

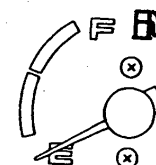

Fuel gauge

## 2. OPERATION

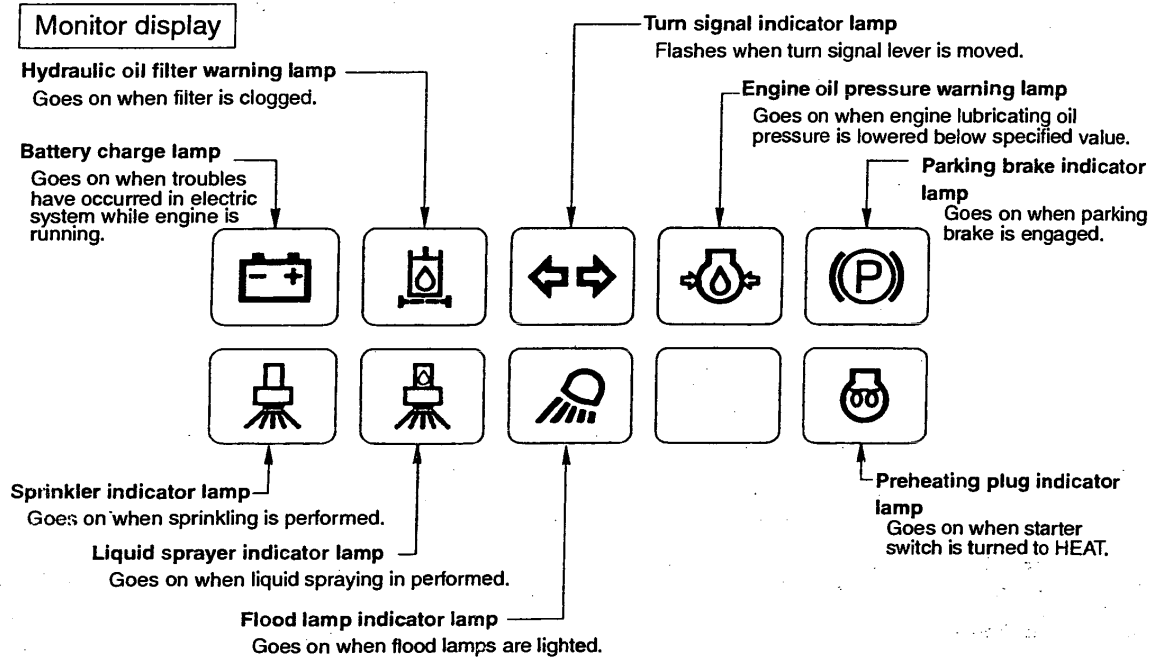

★ Indicator lamps [       ]  
Light up when corresponding systems have been operated.

★ Warning lamps [    ]

Go on when the starter switch is turned to the ON position and go off when the engine has started. If any of them lights up while the engine is running, this indicates a faulty condition. Stop the engine and trace the source of trouble.

★ Bulb failure check

= Warning lamps and parking brake indicator lamp =

They should go on when the starter switch is turned to the ON position.

If not, corresponding bulb has burnt out.

### IMPORTANT

- Hydraulic oil filter warning lamp may go on when the engine rpm is increased before the engine has been warmed up enough. Keep the engine idling until the lamp goes off, before starting your work.
- The engine check lamp comes on when the start switch is turned "ON," and it goes out when engine check is completed. If the engine check lamp does not go out during startup or if it comes on during operation, the engine has failed or some other error has occurred. Look into the cause.
- The boost temperature lamp comes on when the supercharging temperature is high. If it comes on, look into the cause. (Air cleaner clogging, etc.)

2.1.3 Switches

Starter switch

Starts and stops the engine.

OFF: The key can be removed in this position. All the electric systems are switched off. To shut down the engine, move the key to this position.

ON: The charging circuit and lamp circuit are charged with electricity. Let the key stay in this position after the engine has started.

START: The engine is cranked and gets started. The moment the engine has started, release the key. It will automatically return to the ON position.

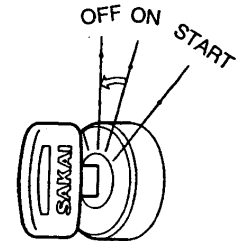

Lamp switch

Has three positions.

○ : All lamps are switched off.

≡D : Side marker lamps and tail lamps come on.

≡D : In addition to the above-mentioned lamps, the headlamps become bright. For high beam, move the turn signal lever up. For low beam, move it down.

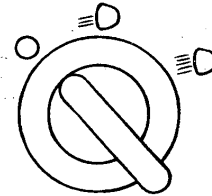

Turn signal lever

Turn signal lamp flashes when the turn signal lever is operated.

Left turn: Move the lever forward.

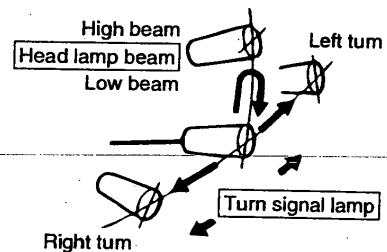

Right turn: Move the lever backward.



**NOTE:** The lever does not return to the OFF position even if the steering wheel is turned back.

## 2. OPERATION



### Flood lamp switch

The flood lamps fitted at the rear of machine light up with the indicator lamp  on the monitor display coming on when switch  is pressed down. The lamps come off if the switch is pushed down again.

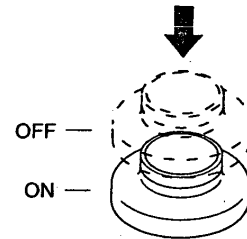
**NOTE:** Do not drive on the load with the flood lamp lighted up. You can obstruct traffic.



### Parking brake switch

If switch  is pressed down, the parking brake applies with the indicator lamp  on the monitor display lighted up.

When pressed again, the brake is released and the indicator lamp goes off.

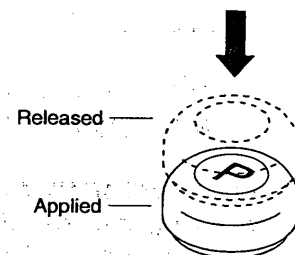

### **⚠ WARNING**

- To disengage the brake, be sure to press the button again instead of pulling it.
- When dismounting from the machine, press the button to apply the brake without fail.

### **⚠ CAUTION**

- Never pull the switch UP.

### **IMPORTANT**

- In an emergency, stop on the brake pedal.

## 2. OPERATION

### Horn switch

Pressing the button at the center of the steering wheel makes the horn sound.

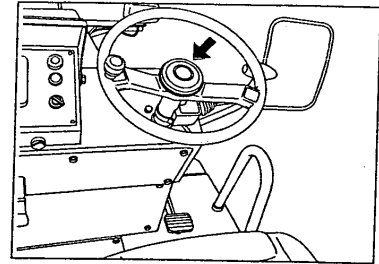

### Vibrator switch

Turns on/off vibration ON-OFF and changes vibration amplitude.

Switching from 1 to 4 causes vibration at higher amplitude. Vibration 1 operates even in stop state if the engine speed is about 2,000rpm or higher, but vibration 2 to 4 operates only while moving forward or backward.

When the forward-reverse lever is placed in the neutral position during rolling compaction work at vibration 2 to 4, return is made to the amplitude of vibration 1. Tilting the lever again resets the amplitude to the selected one of 2 to 4.

At vibration 1, the vibration indicator lamp on the left side lights and at 2 to 4, two indicator lamps, right and left, light.

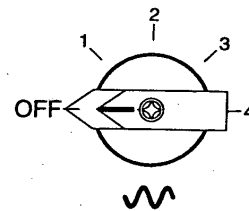

**NOTE:** The vibration rolling compaction should be made at 2,000rpm or higher of the engine speed.

### IMPORTANT

- Avoid long-time vibration at vibration 1 while the machine stops.
- If traveling becomes impossible due to mud, etc. during vibration rolling compaction, immediately stop vibration.
- Because of the characteristic of the amplitude selector system, switching to lower amplitude such as from 4 to 3 or from 3 to 2 cannot be sensed, and in order to switch to lower amplitude, therefore, turn the amplitude selector switch to "OFF" once, and then select the amplitude again.

The vibrator switch mounted on the F-R lever also shuts off vibration.

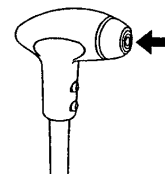

## 2. OPERATION

### Sprinkler switch / Sprinkler timer

The sprinkler switch and sprinkler timer are both used for sprinkler operation.

Sprinkler switch selects continuous sprinkling, and intermittent sprinkling.

Switch selects the sprinkler modes.

ON : Continuous sprinkling is performed.

OFF : Sprinkling is shut off.

INT. : Intermittent sprinkling takes place.

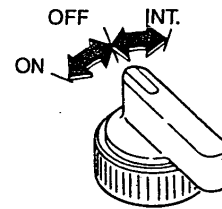

Sprinkler switch

For the intermittent sprinkling, set the sprinkler timer at the desired sprinkling duration and idling duration (Sprinkler Dial ①, Idle Dial ②). Then turn sprinkler switch to the TIMER position. Sprinkling will start.

Sprinkling duration can be adjusted within 0 ~ 20 seconds with dial ①. Idling duration can be set within 0 ~ 60 seconds by turning dial ②. Adjust the dials to meet job conditions.

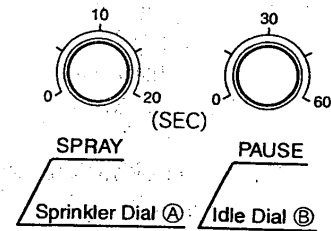

The table below serves as a guide for sprinkling and idling durations.

Vehicle speed (km/h)	Sprinkling duration (seconds)	Idling duration (seconds)
2 (1.2 mile/h)	7 ~ 8	35 ~ 40
3 (1.9 mile/h)	4 ~ 5	30 ~ 35
4 (2.5 mile/h)	3 ~ 4	25 ~ 30
5 (3.1 mile/h)	2.5 ~ 3.5	20 ~ 25

For normal operation (3 km/h, 1.9 mile/h), use the sprinkler with a sprinkling duration of 5 seconds and an idling duration of 30 seconds. Adjust according to job requirements.

When compacting asphalt mixes, select ON to fully wet the drum surface, then switch to INT. Follow the same procedure for starting the work after a short break.

## 2. OPERATION

### Liquid spray switch

When switch  is pressed, spraying is performed on the rear wheels.

To spray, press the switch. Spraying is shut down if the switch is released.

Through the spraying operation, the liquid spray indicator lamp stays bright.

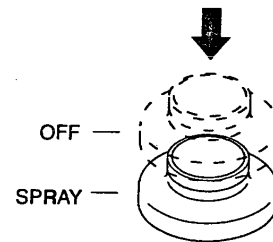

### ⚠ CAUTION

**Watch the liquid level. Troubles will result if the pump operates with the tank empty.**

### 2.1.4 Operating levers and pedals

#### Forward-reverse lever (F-R lever) with vibrator switch

Moving the F-R lever forward or backward makes the machine travel forward or backward respectively. The neutral position brings the machine to a stop. The vehicle speed increases or decreases in proportion to the lever displacement.

The vibrator ON-OFF control is easily made by the F-R lever top vibrator switch (See page 23).

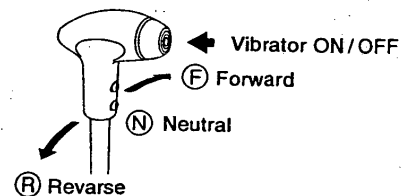

### IMPORTANT

- For normal braking, return the F-R lever back to neutral.
- In an emergency, depress the brake pedal. More powerful braking will take place.

### Throttle lever

Shifts the engine RPM.

The engine RPM increases when moved toward the operator.

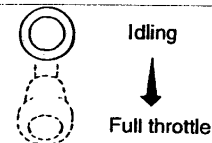

## 2. OPERATION

### Speed shift lever

Selects three vehicle speed ranges.  
Place the switch at the desired position.

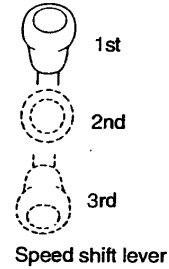

Speed shift lever	1st	2nd	3rd
Travel speed	0~3 km/h (0~1.9 mile/h)	0~5 km/h (0~3.1 mile/h)	0~9 km/h (0~5.6 mile/h)

### Brake pedal

In an emergency, push down on the pedal to the full extent, and the machine will come to a sudden stop.

### IMPORTANT

**Do not use the pedal wherever practicable except for an emergency. If used during the compacting operation of asphalt pavement, this can cause damage to its surface.**

**NOTE:** Depressing the brake pedal brings the F-R lever into neutral (N).

### 2.1.5 Unloader valve

To gain access to the unload valve, open the cover at the left hand side of the operator's seat. The unloader lever disengages the drive, playing a role like a clutch. Use this lever for towing the machine when the engine is disabled or when troubles have developed in the hydraulic drive.

For towing:

Turn the knob counter-clockwise (Unload).

For normal traveling:

Turn the knob clockwise (Onload).

**⚠ WARNING**

- On a slope, chock the wheels and use extreme care when handling the unloader lever and towing the machine.
- Be sure to apply the parking brake when operating the unloader lever.

**NOTE:** For normal travel, be sure to hold the lever in the ONLOAD position.

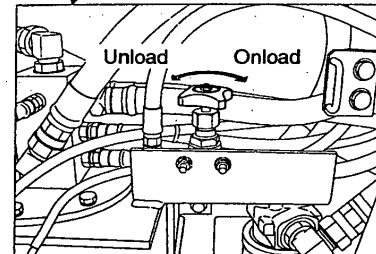
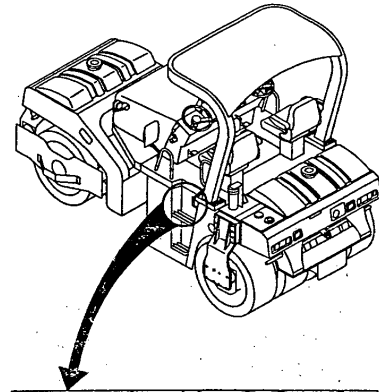

### 2.1.6 Fuse box

**⚠ WARNING**

When changing a fuse, cut the power supply by turning the starter switch to the OFF position.

Fuses protect electrical components and wiring from burning. Change any fuse which has become powder-coated due to deterioration or which has a play between it and fuse holder. To replace fuses, take off the cover. Be sure to use fuses of correct capacity.

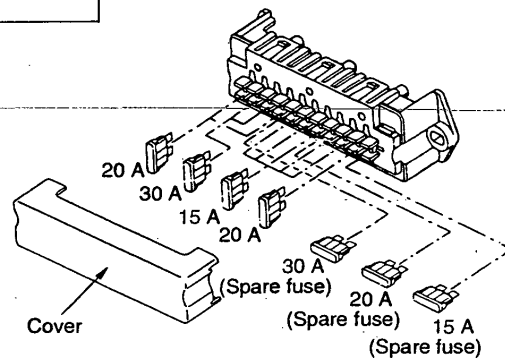

## 2. OPERATION

### 2.2 Handling and Adjustments

#### 2.2.1 Seat adjustment

- 1) Pull the lever ① and adjust seat position longitudinally.
- 2) Turn the backrest adjust dial ② for optimum angle.
- 3) Move the suspension lever ③ to select suitable suspension for your body weight.

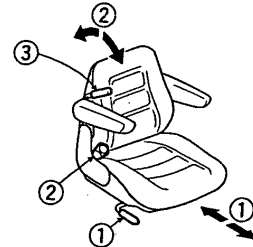

#### ⚠ WARNING

The adjustment will be necessary when operating the machine first or when operators are alternated.

#### 2.2.2 Disengaging the brake when towing

#### ⚠ WARNING

On a slope, chock the wheels and prepare for towing before disengaging the brake.

For towing the machine when the engine is disabled or when troubles have developed in the hydraulic system for propulsion, disengage the brake as instructed below:

- 1) Loosen the lock ring of the selector valve and turn the valve knob counterclockwise until it stops.
- 2) Pull up and press the knob of the pump. The parking brake can be released by pressing it about 13 times.
- 3) After the traction is completed, be sure to turn the selector valve knob clockwise until it stops and fix it with the lock ring.

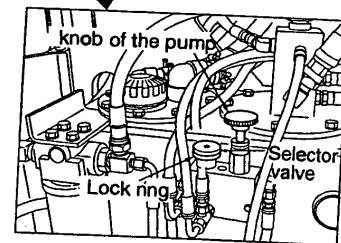
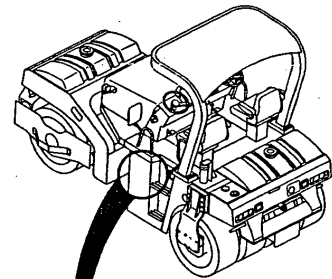

## 2.3 Operation

### ⚠ WARNING

- This machine is a one-man roller.
- Operate the machine from the operator's seat.

### 2.3.1 Before-starting inspection

- 1) Check that the steering lock bar is in the carrying position.

### ⚠ WARNING

Make sure that the steering lock bar is connected in the carrying position before putting the machine in motion. Steering is impossible if the bar is in the steering lock position.

The bar is located at the left of the center of the machine.

To unlock the bar:

- ① Remove the spring pin.
- ② Pull out the lock pin.
- ③ Set the bar in the carrying position.

**NOTE:** Retain the lock bar in the locked position by inserting the lock pin into the lock holes. Fix the lock pin with the spring pin.

- 2) Check that the F-R lever is in the neutral position (N).

**NOTE:** The engine does not start if the F-R lever is not in the neutral position (N).

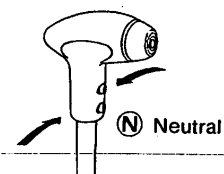
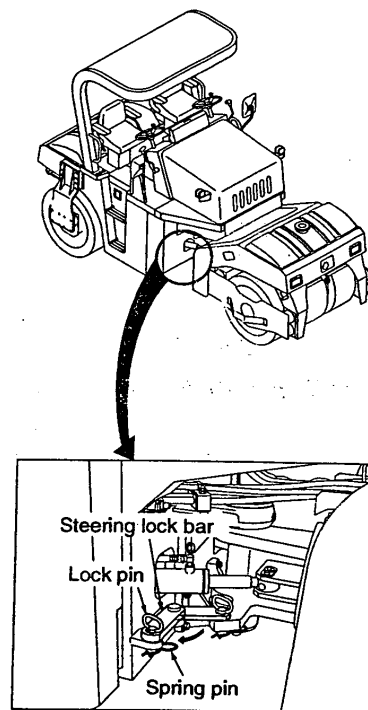

## 2. OPERATION

### 2.3.2 Starting the engine

#### **⚠ WARNING**

Check that the F-R lever is in the neutral position, and sound the horn when starting the engine after making certain that there are no one and no objects close to the machine.

- 1) Turn the starter switch to the ON position and check that the warning lamps and parking brake indicator lamp on the monitor display are on.

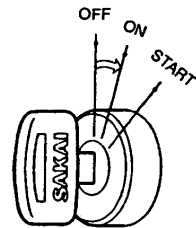
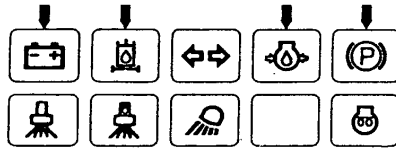

- 2) Turn "ON" the start switch, and preheating begins automatically.

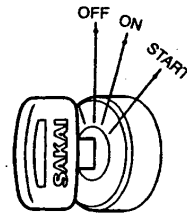

- 3) Turning the key to the START position makes the engine start. Release the key the moment the engine has started. The key will automatically return to the ON position.

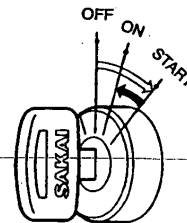

#### **⚠ CAUTION**

- Do not allow the starter key to stay in the START position for more than 25 seconds.
- When startup has failed, leave an interval of more than one minute before restarting the engine.
- Check that the warning lamps on the monitor display go off immediately after the engine is started. If any of these warning lamps becomes bright while the engine is running, shut down the machine, determine the cause and rectify the fault.

**Restarting after gas has run out**

After the gas has run out, operate the manual pump and breather attached to the main fuel tank for sufficient bleeding. Then crank the engine for 25 seconds and stop it for one minute. Repeat this cycle

**⚠ WARNING**

- Do not allow the starter key to stay in the START position for more than 25 seconds.
- When the engine does not start within 25 seconds, leave one or more minutes before restarting.

**2.3.3 After starting the engine**

Try not to move to operation immediately after starting but observe the following:

**IMPORTANT**

**Avoid increasing the engine speed abruptly before warming-up run is completed.**

- 1) Run the engine at around 1,200 rpm for about 5 minutes to warm it up. Warming-up run allows the lubricating oil to reach the vital parts of the engine and hydraulic system, while gradually bringing up the engine oil and hydraulic oil to the working temperature.
- 2) After the warm-up operation, check that:
  - Temperature gauge ..... Slightly above C
  - Fuel gauge ..... Pointer falls between the E and F marks
  - Charge lamp ..... Has gone off.
  - Engine oil pressure warning lamp ..... Has gone off.
- 3) Check for the color of exhaust gas, listen for unusual sounds and vibration. If abnormal, determine the cause and correct the problem.

**2. OPERATION**

**2.3.4 Traveling**

**⚠ CAUTION**  
While travelling, do not turn the starter switch OFF.

**⚠ WARNING**  
When starting, operate the horn after securing the safety around the machine. Clear away obstacles on the road.

1) Select the desired speed by the operation of speed shift lever.

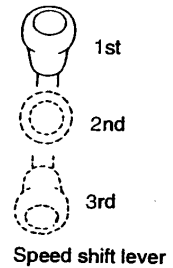

Speed shift lever	1st	2nd	3rd
Travel speed	0~3 km/h (0~1.9 mile/h)	0~5 km/h (0~3.1 mile/h)	0~9 km/h (0~5.6 mile/h)

**⚠ WARNING**  
On a steep slope, run the machine at low speed. Do not attempt to shift speed while travelling.

2) Move the throttle lever toward the operator to increase the engine RPM.

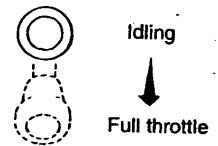

3) Press down parking brake switch button to release the brake. Check that indicator lamp  on the monitor display goes off.

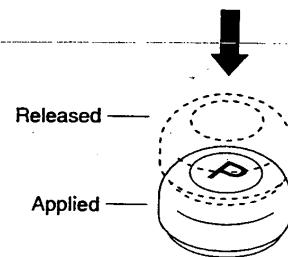

## 2. OPERATION

- 4) Move the F-R lever in the direction to travel, and the machine will begin traveling.

**⚠ CAUTION**  
Avoid abrupt operation of the F-R lever.

**NOTE:** The travel speed can be controlled by the throttle lever and F-R lever.

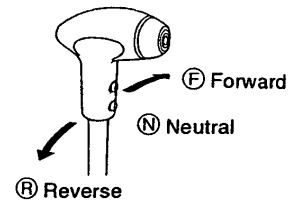

**⚠ WARNING**  
Pay extreme attention to the area behind the machine when backing, since the space just behind it tends to be a blind spot.

### 2.3.5 Stopping / Parking

**⚠ WARNING**

- Avoid abrupt braking. Try to leave enough time for braking.
- Avoid parking on a grade.
- If necessary to park on a grade, block the wheel to prevent unexpected moving down the grade.

- 1) Bring the F-R lever to the neutral position (N), and the machine will come to a halt.

**⚠ CAUTION**  
For normal braking, move the F-R lever back to the neutral position. In an emergency, depress the brake pedal. The F-R lever is brought back to the neutral position.

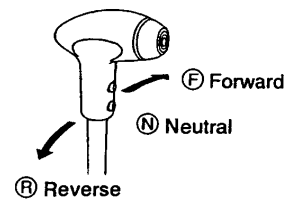

**⚠ WARNING**  
Frequent use of the brake pedal may damage the motor.

- 2) Press the parking switch button securely, and check that indicator lamp  illuminates.

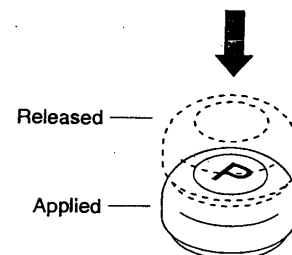

## 2. OPERATION

### 2.3.6 Stopping the Engine

- 1) Gradually cool down the engine at low idling for about 5 minutes

#### IMPORTANT

- Do not bring a hot engine to a sudden stop except for an emergency. This will shorten the life of its component parts.
- Do not also allow an overheated engine to come to a sudden stop, but run it at middle idling speed for gradual cooling down.

- 2) Turn the starter key to the OFF position to stop the engine.

#### CAUTION

While travelling, do not turn the starter switch OFF.

- 3) Pull off the starter switch key.

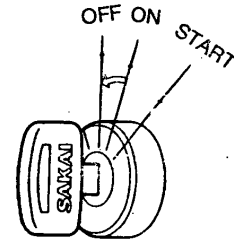

#### WARNING

- When dismounting from the machine, apply the parking brake by actuating the parking brake switch. If necessary to park on a slope, chock the drums.
- Remove the starter switch key.

### 2.3.7 Check after Stopping the Engine

- 1) Perform the walk around checks for oil and water leakage, abnormal signs around the wheels.
- 2) Fill the fuel tank.
- 3) Remove waste paper if any from the engine compartment, as this will pose a possible fire hazard.
- 4) Scrape mud or other materials from and around the drums.

### 2.4 Vibratory Operation

1) Run the engine at 2,000 rpm or higher by operating the throttle lever.

2) Switching from 1 to 4 causes vibration at higher amplitude.

Vibration 1 operates even in stop state if the engine speed is 2,000 rpm or higher, but vibration 2 to 4 operates only while moving forward or backward.

When the forward-reverse lever is placed in the neutral position during rolling compaction work at vibration 2 to 4, return is made to the amplitude of vibration 1. Tilting the lever again resets the amplitude to the selected one of 2 to 4.

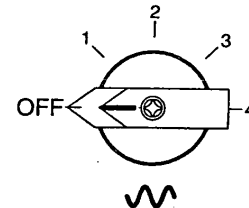

#### IMPORTANT

- Avoid long-time vibration at vibration 1 while the machine stops.
- If traveling becomes impossible due to mud, etc. during vibration rolling compaction, immediately stop vibration.
- Because of the characteristic of the amplitude selector system, switching to lower amplitude such as from 4 to 3 or from 3 to 2 cannot be sensed, and in order to switch to lower amplitude, therefore, turn the amplitude selector switch to "OFF" once, and then select the amplitude again.

### 2.5 Sprinkler / Changeover valve

1) Before sprinkling, check for the water level in the sprinkler tank with the sight gauge. Add water as necessary.

#### IMPORTANT

Use clean water wherever practicable.

2) Sprinkler switch controls sprinkling. Sprinkler switch selects sprinkler modes; continuous sprinkling mode and intermittent sprinkling mode.

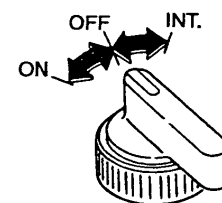

Sprinkler switch

ON .....Continuous sprinkling

INT.....Intermittent sprinkling

Sprinkling duration can be adjusted within 0 ~ 20 seconds with dial (A) . Idleing duration can be set within 0 ~ 60 seconds by turning dial (B) . Adjust the dials to meet job conditions. (Sprinkler Dial (A) , Idle Dial (B) )

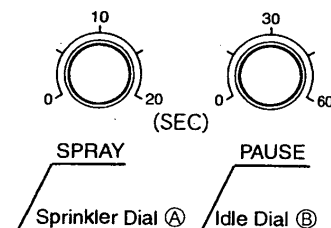

## 2. OPERATION

- The table below serves as a guide for sprinkling and idling durations.

Vehicle speed (km/h)	Sprinkling duration (seconds)	Idling duration (seconds)
2 (1.2 mile/h)	7 ~ 8	35 ~ 40
3 (1.9 mile/h)	4 ~ 5	30 ~ 35
4 (2.5 mile/h)	3 ~ 4	25 ~ 30
5 (3.1 mile/h)	2.5 ~ 3.5	20 ~ 25

- For normal operation (3 km/h, 1.9 mile/h), use the sprinkler with a sprinkling duration of 5 seconds and an idling duration of 30 seconds. Adjust according to job requirements.

### IMPORTANT

- When compacting asphalt mixes, select ON to fully wet the drum surface, then switch to INT. Follow the same procedure for starting the work after a short break.
- Use clean water wherever practicable.
- After the work is completed, turn the handle of the sprinkler filter several times and settle dust in the case. When dust has accumulated in the case, discharge it through the drain cock.

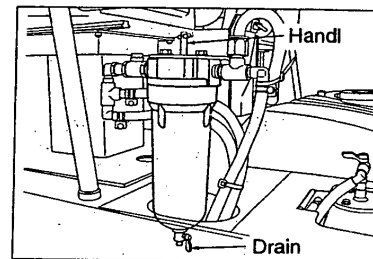

## 2. OPERATION

### Changeover valve

GW750-2 is equipped with one sprinkler pump, and water in the front and rear sprinkler tanks is simultaneously supplied to the pump. If traveling is done on an uphill slope when the water level of the sprinkler tanks is high, water may move from the higher tank to the lower tank resulting in overflowing from the lower tank.

When you park on an uphill slope, shut a valve indicated by the circle.

### ⚠ CAUTION

When the valve is closed, only one tank at the back of the vehicle is used. When the slope changes to a flat road, open the valve quickly. When the valve is opened, the water levels in the tanks in front and behind are flush with each other

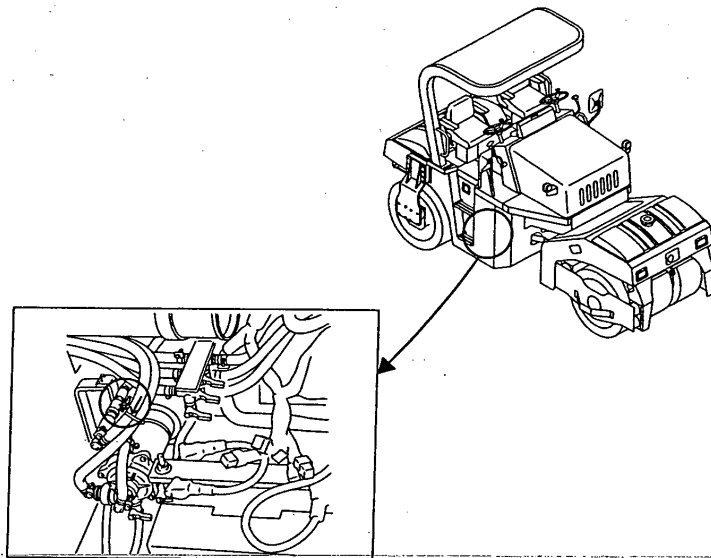

## 2. OPERATION

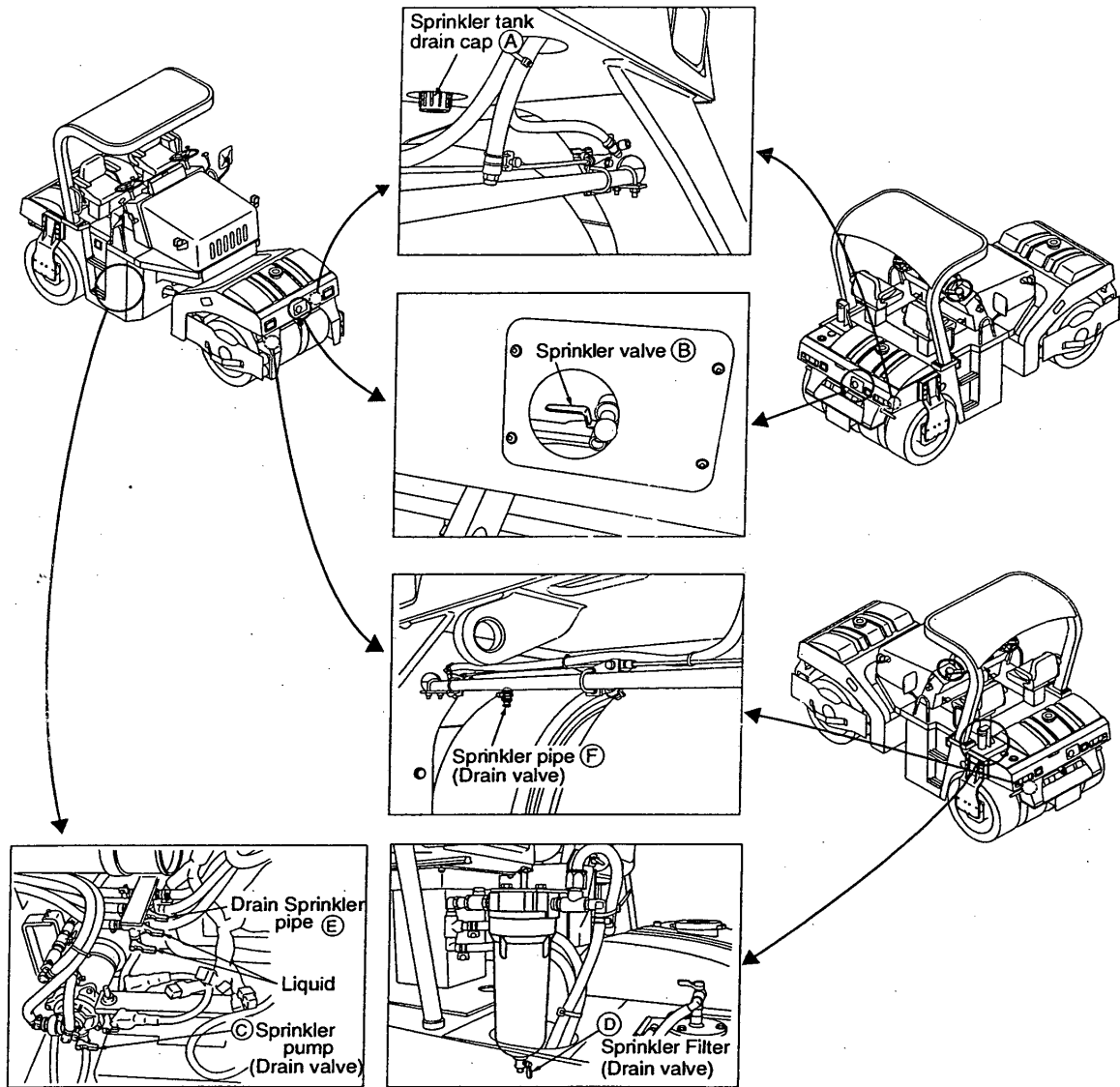

To drain water:

- ① Turn sprinkler tank drain cap **A** counter-clockwise and completely drain the tank.
- ② Completely drain the sprinkler pump, filter, and pipes by removing valves **B**, **C**, **D** and **E**.
- ③ Drain the front and rear sprinkler pipes by opening value **F**.
- ④ In cold weather, also drain the hoses, pump and sprinkler nozzles.

### 2.6 Liquid Sprayer

- 1) Before spraying, check for the liquid level in the tank with the sight gauge. Add liquid as necessary.

**CAUTION**

Driving the liquid spray pump with the liquid tank empty will damage the pump. Pay attention to the liquid level in the tank.

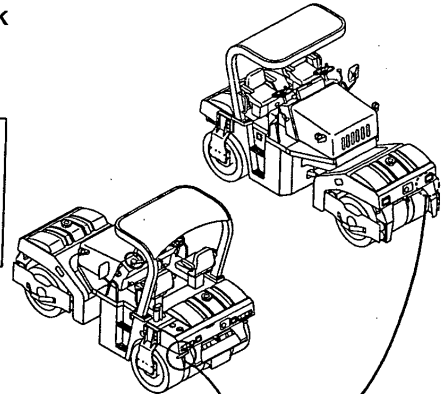

- 2) Fully open liquid spray valve (A) by turning its lever in the closing direction.

**CAUTION**

If an attempt is made to leave the machine unused for a long period, fully close liquid spray stop valve (A) by turning its lever in the closing direction.

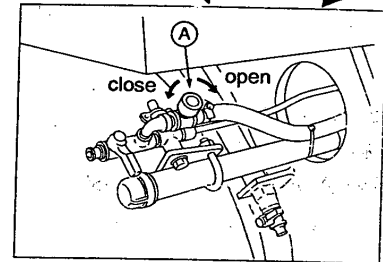

- 3) The liquid to prevent sticking to tires is sprayed by pressing the liquid spray switch and the spraying is automatically stopped when the switch is released.

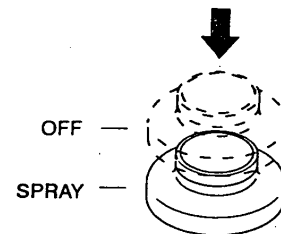

- 4) The liquid spraying rate is adjusted with the spraying rate adjusting valve (A). Adjust the flow rate by turning the valve gradually in the "CLOSE" direction.

## 2. OPERATION

### Adjusting spread of nozzle

When the liquid is sprayed to the tire, the spread of the nozzle should be adjusted so that the liquid will be applied within the tire width.

The spread of the nozzle is adjusted with the round handle of the valve **A** located at the liquid valve end of the front/rear tires.

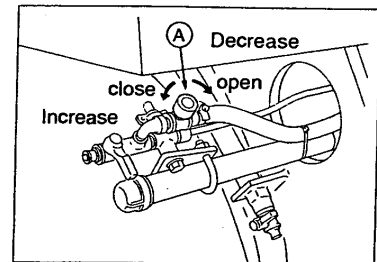

Counterclockwise turning of round handle ..... To increase the spread of the nozzle  
(spraying rate is increased)

Clockwise turning of round handle ..... To decrease the spread of the nozzle  
(spraying rate is decreased)

- 5) In case when such liquid as cutting oil that may be frozen when it is cold, open the valve **B** at the left end of the machine front/rear as well as the valve **C** above the liquid tank after the work is completed, and press the liquid spray switch to drive the pump, and then drain the liquid completely. In addition, the same procedure should be done for long-term storage. Close both cocks when using it again.

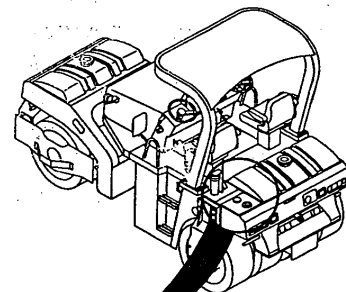
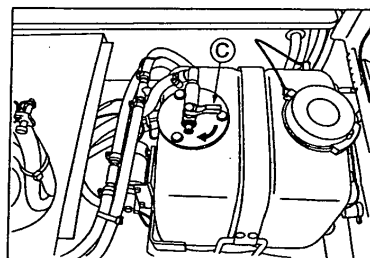

### **CAUTION**

- Diesel oil, kerosene, etc. must not be sprayed to tires because they will cause tire swelling/deformation and asphalt discoloring.
- Pump driving when the liquid tank is empty is allowed only for a short time. If the pump is driven for a long time when empty, failure may be caused. Attention should be paid to the liquid level.

## 2.7 Precautions for Work

### 2.7.1 Compaction operation

#### ■ Rolling compaction of asphalt

- For asphalt compaction, use amplitude 1 or 2.

#### ■ Change the direction of travel gently.

- When changing the direction of travel during asphalt mix compaction, slowly shift the F-R lever.

### 2.7.2 When going downhill

#### ■ Use the F-R lever.

- Run slowly by the operation of the F-R lever even if the travel distance is short.

#### ■ Use the engine brake

- Go downhill by applying the engine brake along with the F-R lever operation.

#### ▲ WARNING

- When going uphill, run at low speed. Do not attempt to shift speeds during travelling. The machine can slip down the slope.

### 2.7.3 On a slope

#### ■ Working on a sidehill

- Work in an uphill/downhill direction, and avoid working on sidehill with the machine inclining sideways.

## **2. OPERATION**

### **2.8 Applicable Jobs**

The machines do a variety of jobs as listed below:

#### **Work**

- Asphalt road paving
- Dust removal treatment for road
- Road improvement
- Embankment construction
- Dam construction
- Construction of forestry and farm roads
- Foundation building
- Construction of sidewalk, shoulder and gutter foundation

#### **Material to be compacted**

- Asphalt pavement
- Crusher run
- Cement concrete
- Sands
- Soils
- Slag
- Soft rock

#### **Layers to be compacted**

- Surface course, Binder course
- Base course
- Subgrade
- Embankment
- Shoulder
- Sidewalk

### **2.9 After Operation**

Check for the coolant temperature, engine oil pressure fuel lever.

Follow the procedures below to prevent the machine from falling into an unworkable condition the following morning caused by muds and other extraneous matter on the drum, or frozen drums:

- 1) Remove muds and water from the machine. Muds can get into the seals together with water drops on the hydraulic cylinder piston rod. Damaged seals will result.
- 2) Park the machine on a hard and dry surface. If such a place is not available, cover the ground with hard plates.
- 3) Low temperature will cause a significant reduction of battery efficiency. Cover batteries or take them off from the machine and store in a warm place for the following day's operation.
- 4) To prevent freezing, drain water from the sprinkler system (See page 38).

**IMPORTANT**

Insufficient draining of water can cause troubles or damage to the system.

## 2.10 Loading and Unloading

**▲ WARNING**

- Use sturdy ramps with proper width, length and thickness which allow safe loading and unloading.
- If the ramps deflect considerably under load, apply wooden blocks to reinforce them.
- Loading should be conducted on a level and hard ground. Leave a sufficient distance between the machine and the shoulder.
- To prevent slippage on the ramps, keep the drums free from mud, oils, etc. The ramps must also be free of grease, oil and ice.
- Do not steer the machine on the ramps. If the machine is facing in the wrong direction, allow it to dismount from the ramps and correct the direction.

For loading and unloading, use ramps or a proper loading stand.

### 2.10.1 Use of a trailer equipped with a winch

**▲ WARNING**

Placing the unloader in UNLOAD position disrupts the power for traction. Do not enter the areas ahead of and behind the machine. It is very dangerous.

- 1) Engage the trailer brake and chock its wheels. Fix the ramps so that the machine and trailer are completely aligned.

- ☆ The angle between the ramps and ground must be less than 15 degrees.
- ☆ Leave a proper space between the ramps according to the width of the roller drum.

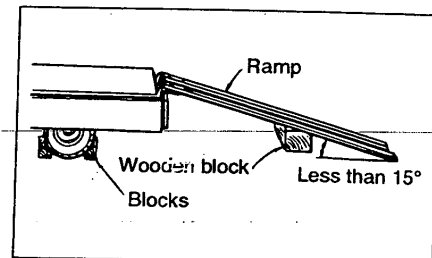

- 2) Decide the correct direction of run and make the machine run forward to the ramps.

## 2. OPERATION

- 3) Draw the wire rope from the trailer winch and put its hook on the hooking point ① or ② of the roller.
- 4) Place the unloader valve located at the operator's station to the UNLOAD position (See "Unloader valve" on page 27).
- 5) Run the engine at a low speed, release the parking brake, and then use the winch of the truck for loading and unloading.
- 6) When the loading is completed, set the unloader valve back in the ONLOAD position.
- 7) Locate the machine correctly on the trailer.

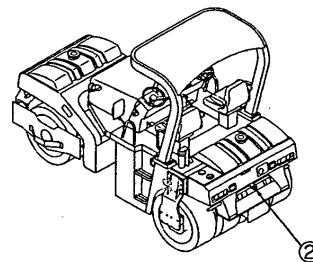
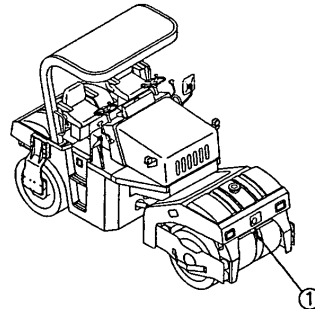

### 2.10.2 Self-propelling

- 1) Engage the trailer brake and chock its wheels. Fix the ramps so that the machine and trailer are completely aligned.

☆ The angle between the ramps and ground must be less than 15 degrees.

☆ Leave a proper space between the ramps according to the width of the roller drum.

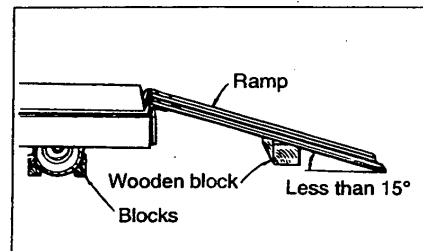

- 2) Decide the correct direction of run and conduct loading or unloading at low speed.

For loading, run forward at low speed.

For unloading, run backward at low speed.

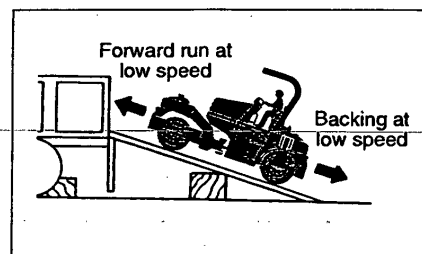

- 3) Locate the machine correctly on the trailer.

### 2.11 After Loading the Machine

When the machine has been located properly on the trailer, tie it down as follows:

- 1) Press the parking switch button to apply the parking brake. Place wooden blocks under the drums to prevent movement.
- 2) Fix the machine with ropes tied at the front and rear towing hook holes. Particularly, pay attention to sidewise skidding.

### 2.12 Transportation

#### **▲ WARNING**

To decide the transporting route, check the width of the road, height and weight (including the roller) of the trailer. Obey relevant regulations.

For transportation, obey traffic regulations.

### 2.13 Operation in Cold Weather

In cold weather, take the following measures to prevent troubles such as starting difficulty and coolant freeze-up.

#### 2.13.1 Fuel oil and grease

Use fuel and oil with low viscosity. See "Rating" on page 67.

## 2. OPERATION

### 2.13.2 Coolant

#### ⚠ WARNING

Do not bring an open flame to the antifreeze or do not smoke when handling it. It is inflammable.

#### ⚠ CAUTION

Never use methanol-, ethanol- and propanol-base antifreeze.

Use soft water for coolant.

In freezing weather, add antifreeze to the coolant referring to the table below. Select the most suitable mix ratio according to the lowest temperature in the job location.

Ambient temperature	-33°C (-27.4°F)	-26°C (-14.8°F)	-20°C (-4°F)	-16°C (3.2°F)	-11°C (12.2°F)
Amount of anti-freeze	6.6 l (1.7)	5.9 l (1.6)	5.3 l (1.4)	4.6 l (1.2)	4 l (1.1)
Amount of coolant	6.6 l (1.7)	7.3 l (1.9)	7.9 l (2.1)	8.6 l (2.3)	9.2 l (2.4)
Ratio	50%	45%	40%	35%	30%

Long life coolant is used in our roller. Useful life of this antifreeze coolant is 2 years.  
Use non-amine type long-life coolant when changing coolant.

#### IMPORTANT

Use of a high consistency antifreeze coolant in summer time can cause the engine to overheat depending upon job conditions. Use a coolant with the water-antifreeze ratio of 70 to 30.

2.13.3 Battery

**⚠ WARNING**

- Batteries generate explosive gases. Do not use an open flame close to batteries.
- The battery electrolyte is corrosive. Keep the electrolyte away from your eyes and skin. If you are affected by the electrolyte, flush with large quantities of water and get medical help.

At low temperature, batteries are less efficient. The level of charge is lowered and batteries will tend to freeze. Maintain batteries full charged wherever practicable, and give attention to heat insulation at night for the next day's operation.

Check the color of the hydrometer attached to the battery top to charge or replace the battery.

Green ..... Good  
Black ..... Discharged too much  
White ..... Checking required

## **2. OPERATION**

### **2.14 When the Cold Season is Over**

When winter is over and the warm season has come, proceed as follows:

- 1) Change oil and fuel with those for use in warm season referring to "Rating" on page 67.
- 2) If AF-PT antifreeze is in use, drain the coolant completely, wash clean inside the cooling system, and then fill with clean water (city water).

### **2.15 For a Long Storage Period**

For leaving the machine unused for longer than one month, proceed as follows:

- 1) Store the machine in a closed area after cleaning.
- 2) Conduct oiling, greasing and changing of oil.
- 3) Grease lubricate the exposed portion of hydraulic cylinder piston rods.
- 4) Cover the battery after disconnecting the negative cable or take off the battery from the machine and store in a safe place.
- 5) If the temperature is expected to go down below 0°C, add antifreeze to the coolant.
- 6) Completely drain the sprinkler system.
- 7) Place the F-R lever in the neutral position (N), turn the vibrator and sprinkler switches off and apply the parking brake.
- 8) Chock the machine.
- 9) Remove the starter switch key.

### **2.16 During the Storage Period**

#### **⚠ WARNING**

**If necessary to operate the machine for anti-corrosive purpose in closed area, ensure good ventilation keeping windows and doors open to prevent gas poisoning.**

- During storage, operate the machine at least once a month to prevent the oil films on the lubricated parts from deteriorating and to charge the batteries.

## 2.17 When the Battery Has Discharged

**⚠ WARNING**

- To check and handle the batteries, keep the engine stopped with the starter switch in the OFF position.
- The batteries give off explosive gases. Do not smoke close to the batteries. Keep flames and sparks away from the batteries.
- The electrolyte is very corrosive and will harm your clothing or skin. If the electrolyte has come into contact with your clothing or skin, flush with sufficient amount of water. In case the electrolyte has gotten into your eyes, flush with water and get medical help.
- To disconnect the battery cables, start with the negative terminal (earth). When connecting, start with the positive terminal. Do not allow a metallic item to bridge between the positive terminal and machine body. This can generate sparks, causing an explosion.
- Loose battery terminals can cause sparks. An explosion will result. When connecting the terminals, make certain that they are tight.

Disconnect with negative cable first

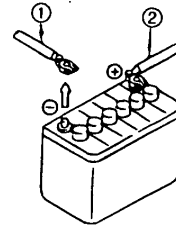

Connect with positive cable first

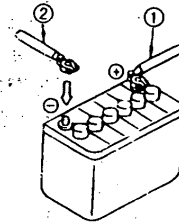

## 2.17.1 Connection and disconnection of booster cables

When jump-starting the engine, connect the booster cables as follows:

■ **Connection of booster cables**

- 1) Connect one end of the positive booster cable (A) to the positive (+) terminal of the battery on the machine.
- 2) Connect the other end of the positive booster cable to the positive (+) terminal of the booster supply.
- 3) Connect the negative booster cable (B) to the negative (-) terminal of the booster supply.
- 4) Connect the other end of the negative booster cable to a good earth of the engine block of the machine.

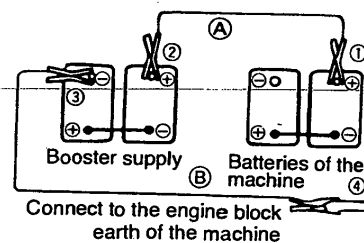

## 2. OPERATION

### ■ Disconnection of booster cables

- 1) Disconnect the negative booster cable (B) from the engine block earth.
- 2) Disconnect the negative booster cable (B) from the booster supply.
- 3) Disconnect the positive booster cable (A) from the booster supply.
- 4) Disconnect the positive booster cable (A) from the machine.

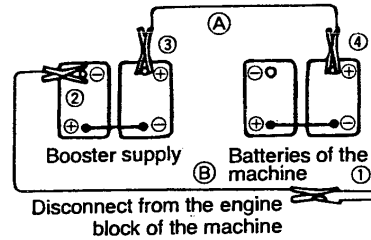

### ▲ WARNING

- Do not allow the positive (+) terminal to make contact with the negative (-) terminal when connecting the booster cables.
- Wear safety goggles when jump-starting the engine.
- Do not allow the machine to make careless contact with the booster supply.
- Do not make wrong connections. Connect the negative (-) cable to the engine block earth far away from the battery, as sparks may occur when connecting.



### ▲ CAUTION

- Use booster cables and end clips of proper size suited to the battery capacity.
- Use the batteries of the equal capacity for the machine and booster supply.
- Check booster cables and end clips for signs of damage and corrosion.
- Connect the clips positively.

### 3. PERIODICAL MAINTENANCE

#### 3.1 Precautions

Whether or not the inspection service and lubrication are performed at the correct regular intervals exerts significant influence on the occurrence of trouble and service life of the machine. In this manual, typical intervals for inspection and service are given. However, flexibility should be introduced as to interval or type of services to enable your machine to always operate in the best condition.

##### General precautions:

- 1) Always use Sakai genuine parts for replacement.
- 2) Use lubricants recommended by Sakai. Avoid mixing different brand lubricants.
- 3) For hydraulic oil replenishment, changing, level checking, filter cleaning or replacement, oiling and greasing, use extreme care to prevent dust from entering.
- 4) For checking oil level or changing oil, park the machine on a level and hard surface.
- 5) Change oil while its temperature remains high after operation.
- 6) For a long-term storage, fill the fuel tank, lubricate necessary points and run the machine for more than 20 minutes once a month.
- 7) In freezing weather, add antifreeze to the coolant according to the ambient temperature.
- 8) For the hydraulic pump and motor, have them serviced at authorized service shops.
- 9) Turn the starter switch OFF when performing services such as repairing broken wires, short circuits and tightening loose terminals.

##### Periodical Replacement of Essential Maintenance Parts

In order secure safety for work and travel, conduct inspection and services.

Further, for enhanced safety, following parts and components should be replaced periodically. These parts are prone to material deterioration due to aging or physical change due to friction, while it is difficult to determine their useful limit by regular inspection, which makes it necessary to replace with new ones after certain period of service to maintain their perfect function.

If any abnormality is detected such as crack, deformation or oil leakage, go ahead and replace them even if it is within scheduled replacement time.

### 3. PERIODICAL MAINTENANCE

System or Mechanism	Part name	Periodical replacement maintenance part	Replacement period	Remarks
1. Brake system	Master cylinder	Seals (rubber parts)	2 years	Adopted machines only
	Wheel cylinder	Seals (rubber parts)	2 years	"
	Brake piping parts	Brake hose	2 years	
		Air hose	2 years	Adopted machines only
	Operating parts	Cable	4 years	"
2. Steering system	Orbitrol	Seals (rubber parts)	2 years	
	Hydraulic piping parts	Hydraulic hose	2 years	
	Steering cylinder	Seals (rubber parts)	2 years	
	Hydraulic pump	Seals (rubber parts)	4 years	
3. Power transmission system (inclusive of axle)	Axle	Seals (rubber parts)	4 years	Adopted machines only
	Travel pump	Seals (rubber parts)	4 years	"
	Travel motor	Seals (rubber parts)	4 years	"
	Hydraulic piping parts	Hydraulic hose	4 years	"
	Isolation rubber	Isolation rubber itself	4 years	"
4. Fuel system	Piping parts	Fuel hose	4 years	
5. Engine related	Engine mounting parts	Isolation rubber	4 years	
	Seals (rubber parts)	Packing and others	4 years	
	Drive parts	V-belt	2 years	
6. Cooling system	Piping parts	Radiator hose	2 years	
7. Control related parts	Cable	Cable	4 years	Adopted machines only

#### ⚠ CAUTION

- With a new machine, change the engine oil after 50 hours of operation for the first time only. (Refer to page 59)
- When trouble occurs in the location indicated by the indicator lamp on the monitor display, sensor will work and corresponding lamp comes on. If this occurs, conduct necessary service regardless of the periodical service interval recommendation.
  - 1) The hydraulic filter (line filter) warning lamp ⇨ Replace elements
- Check the electric wiring at a regular interval not exceeding one month:
  - 1) Damage to the wire harness and loose clamps
  - 2) Loose sockets
  - 3) Function of electrical systems

### 3. PERIODICAL MAINTENANCE

#### 3.2 Walk-Around Checking

For efficient operation, daily, before-operation checking is very important. Before starting, perform walk-around checking for loose bolts, nuts and signs of leakage in addition to items as shown below:

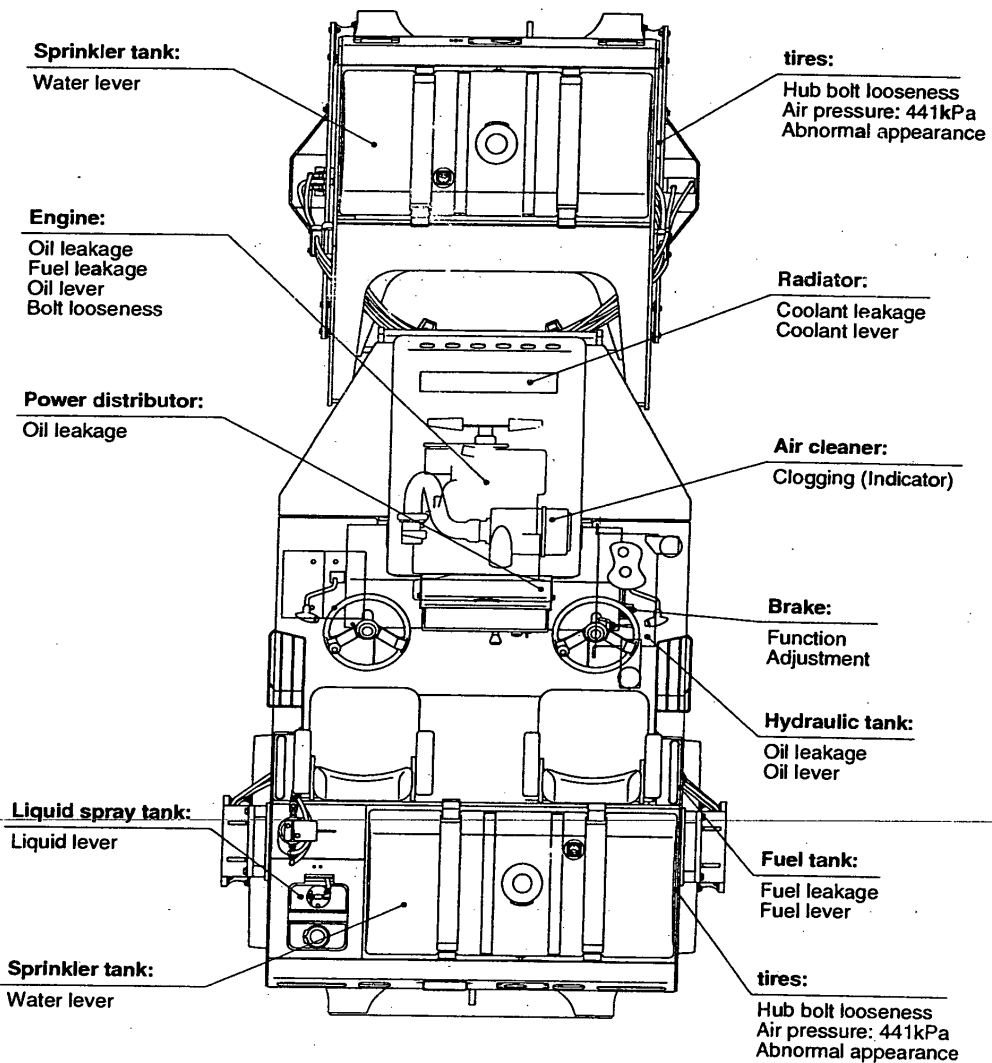

### 3. PERIODICAL MAINTENANCE

#### 3.3 Periodical Maintenance Points

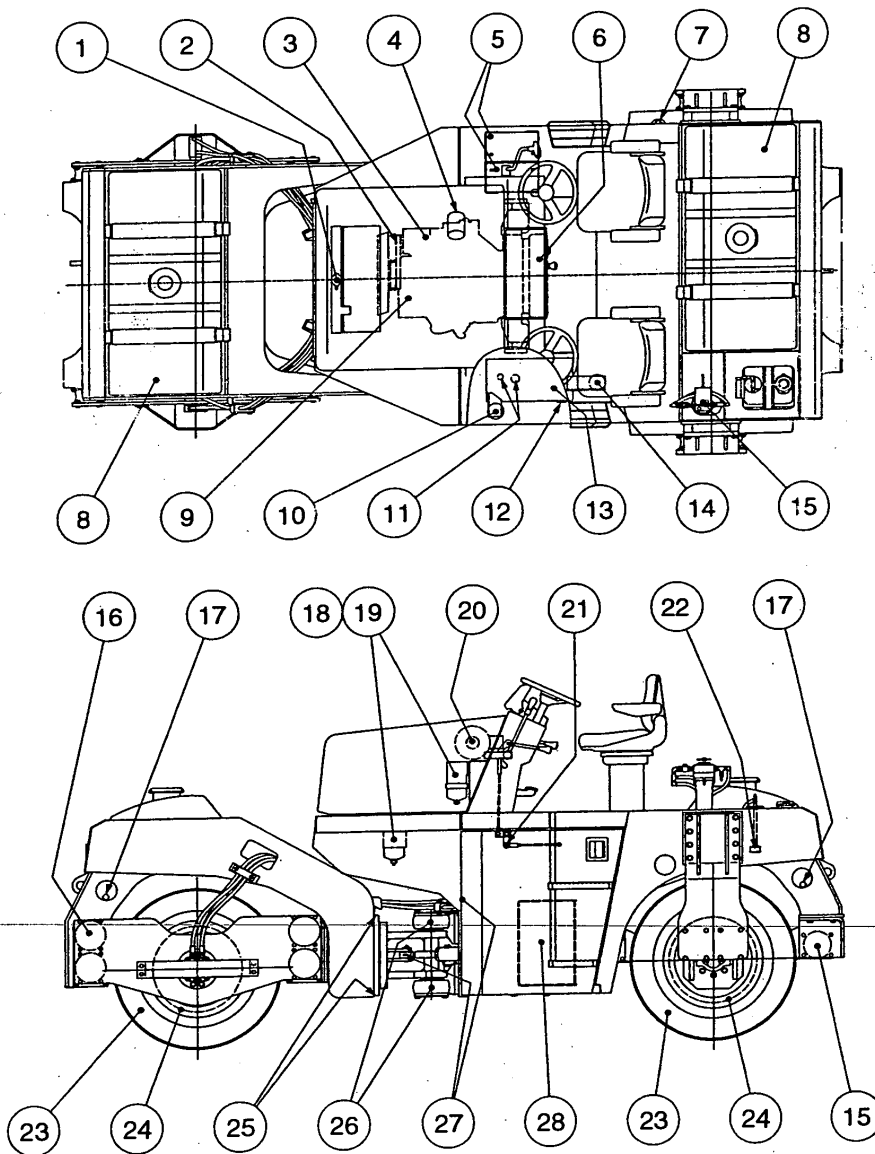

### 3. PERIODICAL MAINTENANCE

Interval	Ref. No.	Item	Service	Lubricant	Q'ty
Every 10 hours or daily	①	Radiator	Check coolant level, add as necessary	Coolant	1
	③	Engine oil pan	Check oil level, add as necessary	Engine oil	1
	⑦	Fuel tank	Check fuel level, add as necessary	Diesel Fuel	1
Every 50 hours	⑤	Battery	Check hydrometer		2
	⑫	Hydraulic level	Check oil level, add as necessary	Hydraulic oil	2
	⑮	Sprinkler filter	Clean element		1
	⑱ ⑲	Fuel filter	Check and remove water and sediment		2
	⑳	Tires	Check condition and air pressure		7
Every 250 hours	②	Fan belt	Check looseness, adjust as necessary		1
	④	Engine oil filter	Replace element		1
	⑥	Power distributor	Check oil level, add as necessary	Gear oil	1
	⑨	Engine oil pan	Change oil	Engine oil	1
	⑯	Shookmounts	Check condition		16
	⑰	Sprinkler pipe, nozzle	Clean internals		—
	⑳	Vibrator	Check oil leakage	Gear oil	3
	㉑	Tilt bearing	Apply grease	Grease	4
	㉒	Center pin	Apply grease	Grease	2
	㉓	Steering cylinder	Apply grease	Grease	4
Every 500 hours	⑩	Line filter	Replace element		1
	⑪	Return filter	Replace element		1
	⑱ ⑲	Fuel filter	Replace element		2
	㉑	Control link	Check looseness and adjust		3
	㉒	Liquid spray strainer	Clean or replace strainer		1
	Every 1000 hours	⑥	Power distributor	Change oil	Gear oil
⑪		Suction filter	Clean element		2
⑬		Hydraulic tank	Change oil	Hydraulic oil	1
㉑		Vibrator	Change oil	Gear oil	3
As required	⑧	Sprinkler tank	Clean internals		2
	㉑	Air cleaner	Clean or replace element		1
	㉒	Fuel tank	Clean internals		1

### 3. PERIODICAL MAINTENANCE

#### 3.4 Maintenance Procedure

➔ For servicing the engine, see the separate engine manual.

(1) Every 10 hours or daily

##### ① Radiator

With the cap removed, check to see if the coolant level is near the port. Add as necessary. Furthermore, idle the engine for two to three minutes, and check that the cooling water inside the reservoir tank is at the position between L and H. If the cooling water is insufficient, remove the cap of the reservoir tank and supply water. Use soft water as cooling water.

##### ⚠ WARNING

Do not remove the radiator cap while the coolant is hot. Before removing, raise the lever on the cap to release the internal pressure.



##### ③ Engine oil pan

Shut down the engine and check the engine oil level. If it is not between MAX and MIN marks, add oil through the fill hole.

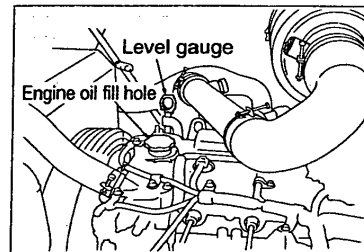

##### ⑦ Fuel tank

Check the fuel level with the fuel gauge or the level gauge. Add as necessary from fill hole.

##### ⚠ CAUTION

For refueling, park the machine on a level and solid surface.

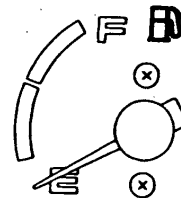

### 3. PERIODICAL MAINTENANCE

#### (2) Every 50 hours

##### ⑤ Battery

1) Check the color of the hydrometer attached to the battery top to charge or replace the battery.

Green ... Good

Black ... Discharged too much

White ... Checking required

2) Retighten any loose terminal. Apply grease or vaseline to the terminals to retard rusting.

##### ⑫ Hydraulic level

Check the oil level with the sight glass on the side of tank. The level is proper if it is between H and L marks. When it is insufficient, open the door at the left side of the vehicle and feed hydraulic fluid from the fill port.

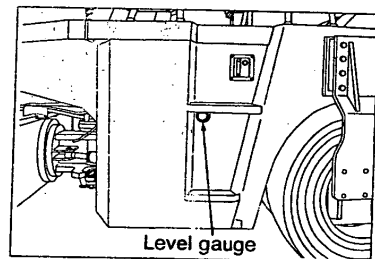

##### ⑮ Sprinkler filter

Turn the filter case counterclockwise to remove it, and then clean the element set inside.

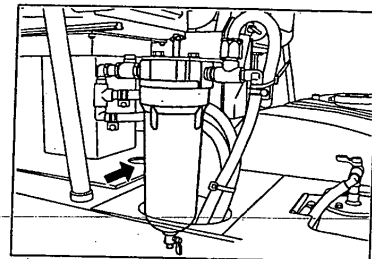

### 3. PERIODICAL MAINTENANCE

#### ⑱ ⑲ Fuel filter

Check the float level. If it comes up to the warning mark, take off the plug at the bottom and drain water.

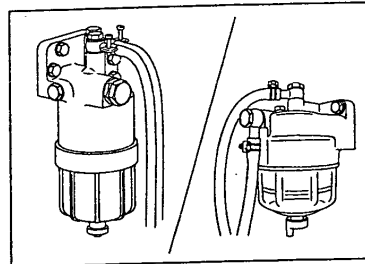

#### ⑳ tires

- 1) Check for unusual wear and damage.
- 2) Check for the inflation pressure. (441kpa)
- 3) Check the wheel bolts for looseness simultaneously.

When any damage or local swelling is observed on the tire, stop traveling and replace the damaged tire with a new one.

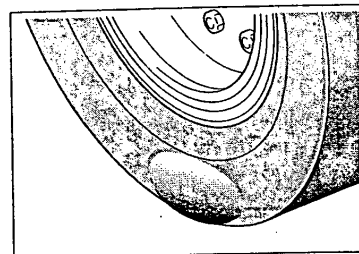
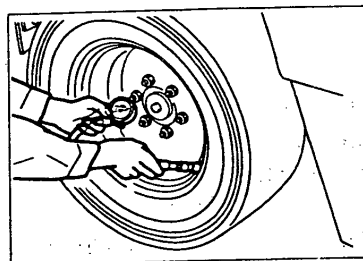

#### (3) Every 250 hours

#### ㉑ Fan belt

- 1) Check the fan belt for wear and damage. Replace as necessary.
- 2) Check the tension. Depress the middle of the belt with a push of about 10kg. A properly adjusted belt deflects 10 to 15 mm.
- 3) Loosen the bolt ㉒ of the adjustor plate and turn the adjust bolt ㉓ to adjust the fan belt.

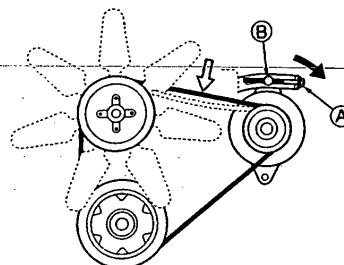

### 3. PERIODICAL MAINTENANCE

④ Engine oil filter

⑨ Engine oil pan

→ See the separate engine manual.

- 1) After completion of operation and while the oil is warm, drain the oil with the drain plug removed.

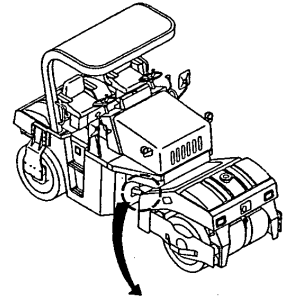

**⚠ WARNING**  
When draining a hot oil, use care not to get burned.

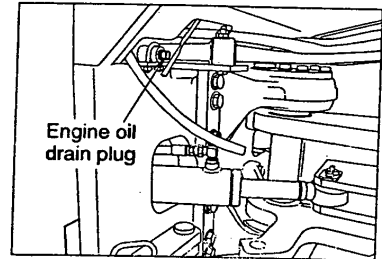

- 2) Refit the drain plug and fill the crankcase with the engine oil from the fill hole on the cylinder head cover.

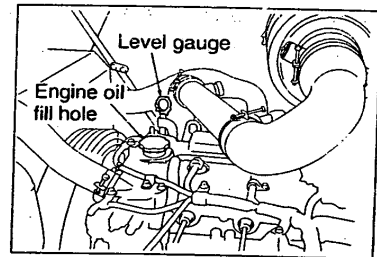

- 3) Change the oil filter.

**NOTE:** For a new machine, change oil at 50 operating hours for the initial time only.

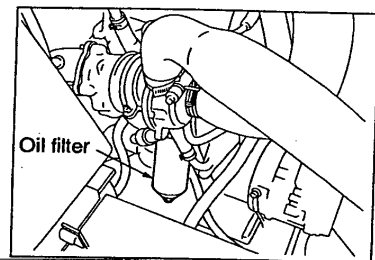

### 3. PERIODICAL MAINTENANCE

#### ⑥ Power distributor

Check oil and add if necessary.

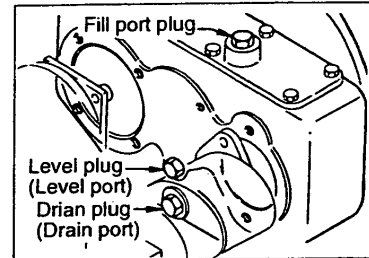

#### ⑩ Shockmounts

Check the rubber blocks for cracks and their mounting bolts for looseness.

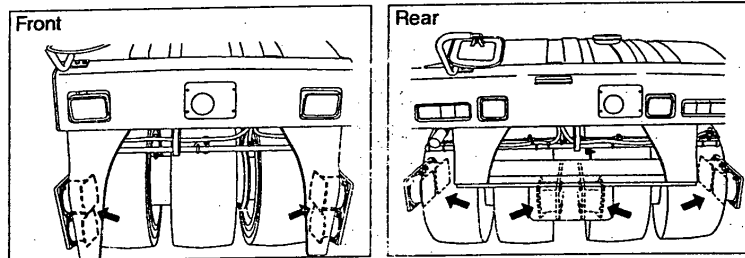

#### ⑰ Sprinkler pipe, nozzle

##### 1) Pipe

Remove the cap from both ends of each sprinkler pipe. Operate the sprinkler pump to wash out dust from inside the pipe.

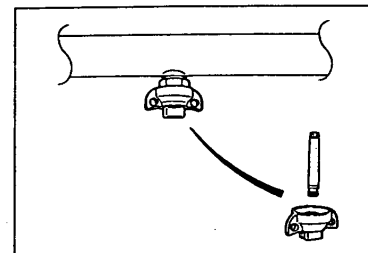

##### 2) Nozzle

- Turn the cap of "one-touch" nozzle to remove the cap and nozzle from sprinkler pipe.
- Turn-out the nozzle from cap and, further, turn-out filter from the nozzle.
- Clean the filter and clean the nozzle holes with needle or the like before replacing them to sprinkler pipe in the reversed order of removal.
- Turn-in the nozzle to cap so that the spray of emulsion is directed across tire width.

### 3. PERIODICAL MAINTENANCE

#### 24 Vibrator

Check for the oil leakage.

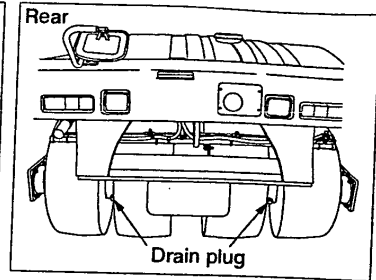
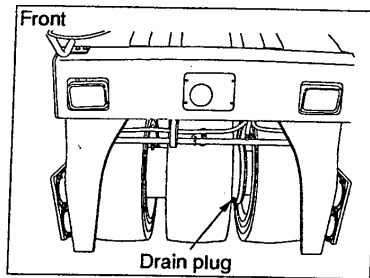

#### 25 Tilt bearing

Grease lubricate two locations.

#### 26 Center pin

Grease lubricate two locations.

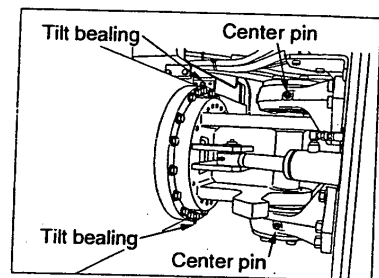

#### 27 Steering cylinder

Apply grease to the four fittings.

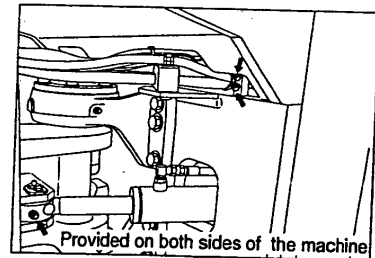

#### 28 Wheel hub nut

Check the wheel hub nut for looseness. If it is loose, tighten it. Be sure to torque it to the specified value.

Tightening torque: 265 N · m

#### CAUTION

- Turn the wheel hub nut in the tightening direction during inspection.
- Excessive tightening of the wheel hub nut will lead to breakage of bolts or cracks in the disc wheel. Be sure to observe the specified torque.

NOTE: Tighten the wheel hub nut 50 hours after purchase of a new vehicle or replacement of tires.

### 3. PERIODICAL MAINTENANCE

#### (4) Every 500 hours

##### ⑩ Line filter

Change the elements.

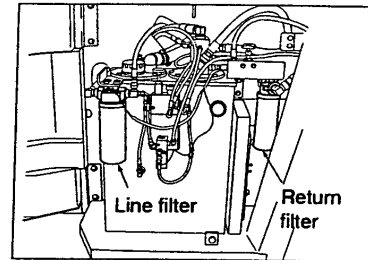

##### ⑭ Return filter

Change the elements.

##### ⑱ Fuel filter

Change the filter cartridge.

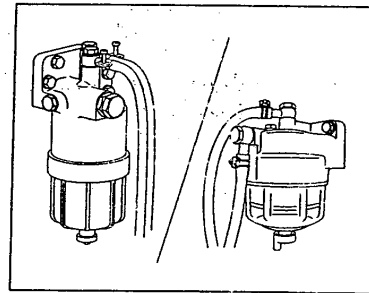

##### ⑳ Control link

Remove the operator seat floor cover and the cover under the dashboard.

Check the bolts and nuts for looseness. Adjust the rod.

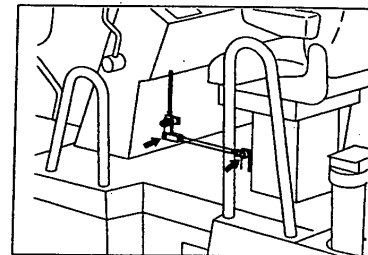

##### ㉑ Liquid spray strainer

Take off the liquid tank cover. Take out and clean the strainer, change the strainer if necessary.

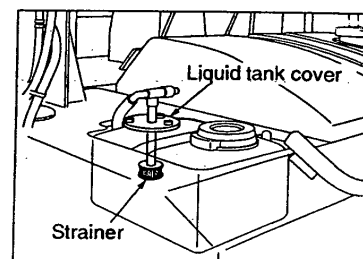

### 3. PERIODICAL MAINTENANCE

#### (5) Every 1000 hours

##### ⑥ Power distributor

- 1) Drain the power distributor oil by removing the drain plug.
- 2) Refit the drain plug.
- 3) Take off the level plug and fill port plug.
- 4) Fill oil through the fill port until oil starts overflowing from the level port.
- 5) Refit the level plug and fill port plug.

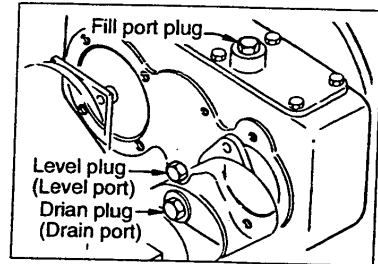

##### ⑪ Suction filter

Take off the hydraulic tank cover. Take out and clean the strainer, change the strainer if necessary.

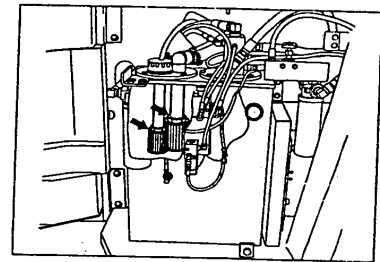

##### ⑬ Hydraulic tank

- 1) Remove the drain plug and drain the oil while it is warm.
- 2) After cleaning the inside of the tank, fill the tank to the specified level with new hydraulic fluid.
- 3) Start and run the engine at idling for 2 ~ 5 minutes. When air bubbles have disappeared from the oil, stop the engine and check the oil level again.

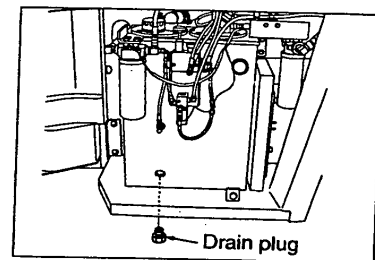

#### ▲ WARNING

When draining a hot oil, be careful not to get burned.

### 3. PERIODICAL MAINTENANCE

#### ④ Vibrator

- 1) Rotate the drum till the drain plug comes to bottom.
- 2) Remove the drain.
- 3) Drain the vibrator oil.
- 4) Turn the tire until the port comes to a position for easy oiling.
- 5) Supply specified amount of oil (Front 3.2 l ,Rear 2.5 l × 2,) through the port using a jug, etc.
- 6) Wash clean the removed plugs, and refit the drain plug.

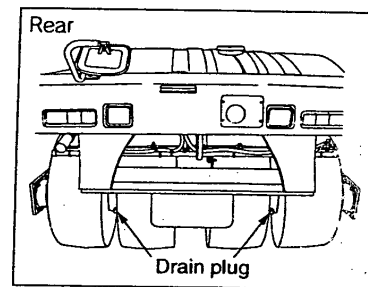
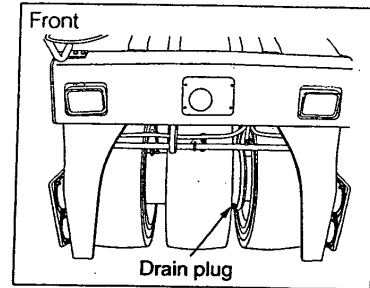

### 3. PERIODICAL MAINTENANCE

#### (6) As required

##### ⑧ Sprinkler tank

- 1) Remove the drain cap under the sprinkling tank located at the machine front/rear and discharge dust and deposit in the tank.
- 2) Remove the filler cap and clean the interior of the tank.
- 3) When the necessary work is complete, refit the drain cap and filler cap.

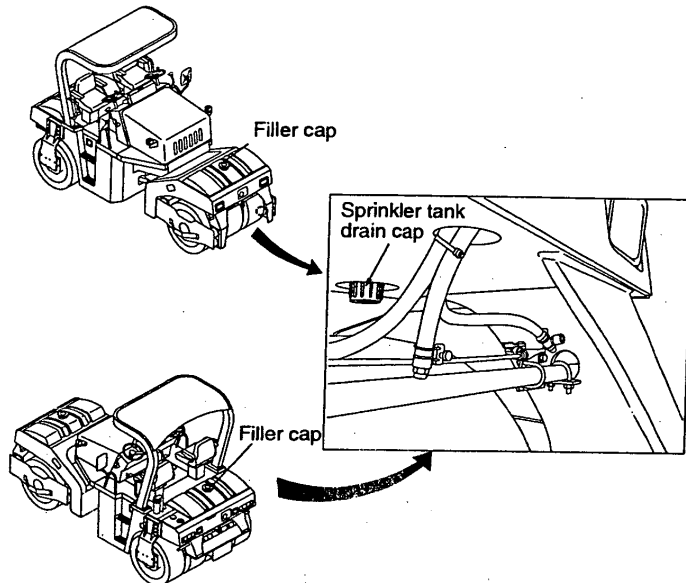

##### ⑩ Air cleaner

When the red float of the dust indicator reaches the service level (a mark on the indicator), clean the element as described below:

- 1) Remove the clip and cap to pull out the element.
- 2) Blow compressed air from inside of the element to clean.

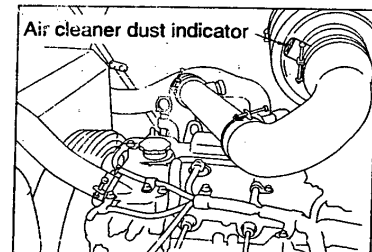

#### ⚠ WARNING

Exercise caution not to get a speck of dust in your eye.

- 3) Check the element for damage. Change if found to be abnormal.
- 4) Refit the element and cap and tighten the clip.

#### ⚠ CAUTION

Replace the element when the red float reaches the service level even if it is cleaned.

NOTE: In normal use, change the outer element once in every six cleanings

### 3. PERIODICAL MAINTENANCE

#### 28 Fuel tank

- 1) With the drain plug removed, remove the water and sediment from the bottom of the tank.
- 2) If sedimentation is substantial, remove the drain plug and clean the interior of the tank.
- 3) When the necessary work and refueling are complete, tighten the filler cap positively.

**NOTE:** When removing the water and sediment from the tank filled with the fuel, the fuel will gush out if the drain plug is screwed out completely.

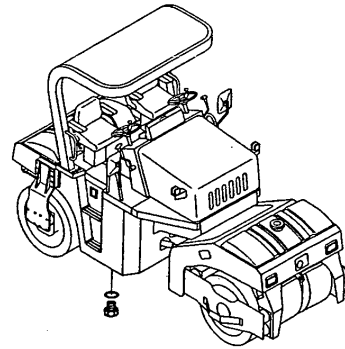

#### ⚠ WARNING

- The fuel will catch fire if open flames or ignition sources are used close to it.
- Do not smoke or use a match or cigarette lighter close to it.



### 3. PERIODICAL MAINTENANCE

#### 3.5 Feeding Water and Lubricants

##### 1. General rules

- 1) Never feed water or lubricant with the strainer removed.
- 2) Use recommended lubricant and hydraulic fluid.
- 3) Do not use lubricants and hydraulic fluid of different brands.
- 4) When replacing oil, drain it completely and clean the container with flushing oil before filling new oil.

##### 2. Capacity

Compartment	Type of fluid	Capacity in liters (gal.)
Engine oil pan	Engie oil	14 (3.7)
Power divider	Gear oil	1.5 (0.4)
Vibrator	Gear oil	Front 3.2 ℓ Rear 2.5 ℓ × 2
Hydraulic tank	Hydraulic oi	65 (17.2)
Fuel tank	Diesel oil	130 (34.3)
Radiator	Coolant	13.2 (3.5)
Sprinkler tank	Water	300 (79.2) × 2

##### 3. Rating

Lubricant	Service classification	Ambient temp. and applicable viscosity rating			Applicable standards
		-15 ~ 30°C (5 ~ 86°F) Cold	0 ~ 40°C (32 ~ 104°F) Moderate	15 ~ 55°C (59 ~ 131°F) Tropical	
Engine oil	API grade CD	SAE 10W-30	SAE 30	SAE 40	MIL-L-2104D
Gear oil	API grade GL4	SAE 80W-90	SAE 90	SAE 140	MIL-L-2105
Hydraulic oil	Wear resistant	ISO-VG32 over VI 140	ISO-VG68 over VI 140	ISO-3448 over VI 110	ISO-3448
Grease	Lithium type extreme pressure				NLGI-2
Fuel	Diesel oil				ASTM D975-2D

### 3. PERIODICAL MAINTENANCE

#### 4. Recommended lubricants

Lubricant Oil company	Engine oil API – CC	Gear oil API GL 4	Hydraulic oil VG 46	Grease (NLGI – II)
CALTEX	RPM DELO 300 oil	Universal Thuban 90	Rando Oil HD 46	Martifack EP 2
BP	BP Vanellus C3-30	BP Gear Oil EP 90	BP Energol HLP 46	BP Energrease LS – EP 2
ESSO	Esso Lube D3-30	Esso Gear Oil GP 90	Nuto H 46	Beacon EP 2
MOBIL	Mobil Delvac 1330	Mobil Pegasus Gear Oil 90	Nuto Oil 25	Beacon EP 25
SHELL	Shell Rotella CT Oil 30	Shell Spirax 90 EP	Shell Tellus Oil 48	Shell Alvania EP Grease 2
CASTROL	Castrol CRD 30	Castrol Hypoy 90	Hyspin AWS 46	Spherrol ELP 2

- CAUTION:**
- 1) Fill the fluid reservoirs with the filters installed.
  - 2) Use recommended fuels and lubricants only.



### 3. PERIODICAL MAINTENANCE

#### Fuse box

The fuse box houses five 15A-, three 20A-, and two 30A- fuses lined up with spares fitted for 15A-, 20A- and 30A- fuses.

Use fuses of correct capacity. See page 27.

**NOTE:** When a fuse is burned, determine the cause before replacing.

#### Battery

- ★ Leaving the battery unused for long without attention or its power excessively at a time can cause damage to the plates, leading to a shortened life.
- ★ For long-term storage, charge it fully, tighten the caps securely, store in a cool and dry place, and check the level of charge at least once a month.
- ★ Keep the battery in a satisfactory condition at all times.
- ★ The battery should be in a satisfactory condition when the engine is to be started on cold days. Avoid starting the engine with the battery in a poor condition at any time.

## 4. SPECIFICATIONS

### 4. SPECIFICATIONS

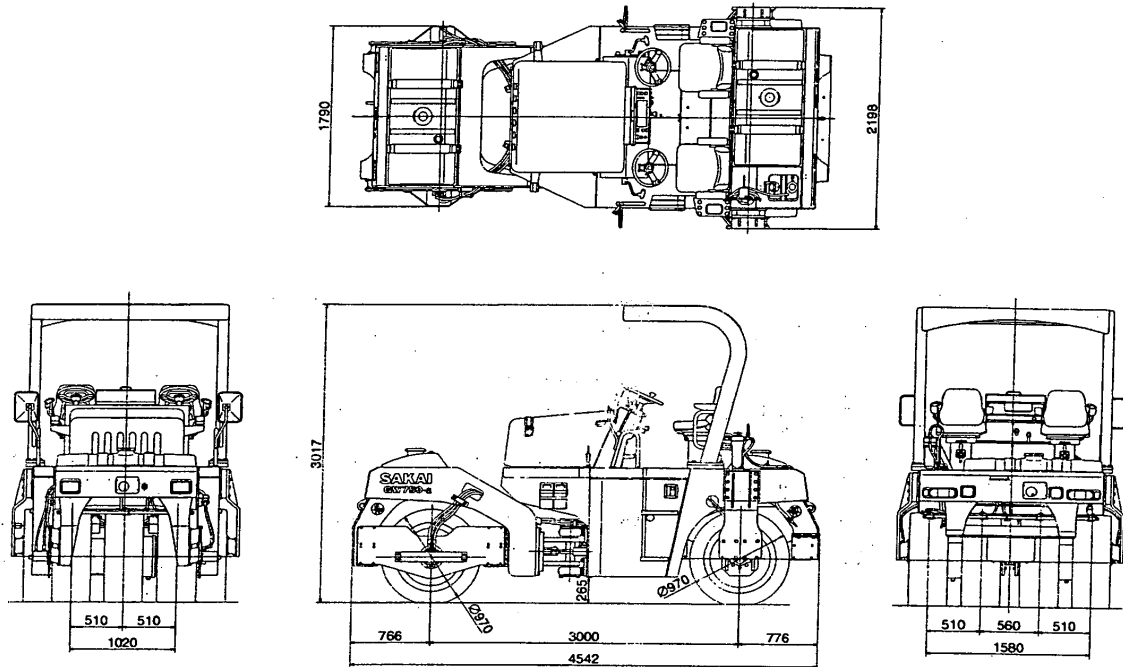

<b>Model</b>		<b>GW750-2</b>		<b>Vibrating power:</b>	
<b>Weight:</b>				Centrifugal force	
Gross weight	9,000 kg (19,841 lbs)			1st	78kN {800kgf}    3rd 41.9kN {4,270kgf}
Empty weight	8,400 kg (18,519 lbs)			2nd	24.5kN {2,500kgf}    4th 58.4kN {5,960kgf}
<b>Dimension:</b>				Gradability	
Overall length	4,540 mm (179")			21 degrees	
Overall width	2,200 mm ( 87")			Rolling width	
Overall height	3,017 mm (119")			1,950 mm (77")	
Wheelbase	3,000 mm (118")			Minimum turning radius	
Wheel				5.4 m (213")	
Front	Tire x 3			<b>Engine:</b>	
	14 / 70 - 20 - 12PR (OR)			Model	
Rear	Tire x 4			ISUZU "4JJ1X" Diesel Engine	
	14 / 70 - 20 - 12PR (OR)			(With turbo charger)	
<b>Performance:</b>		1st	2nd	3rd	Total displacement
Travel speed	0 ~ 3 km/h    0 ~ 5 km/h    0 ~ 9 km/h				4.329 l (245 cu.in)
(forward/reverse)	(0 ~ 1.9 mile/h)    (0 ~ 3.1 mile/h)    (0 ~ 5.6 mile/h)			Rated output	
				78.8kW {107 PS}	
				Max. torque	
				392 N·m {40kgf·m} / 1,800min <sup>-1</sup> {rpm}	
				<b>Tank capacity:</b>	
				Fuel tank	
				130 litres (34 gal)	
				Hydraulic tank	
				65 litres (17 gal)	
				Sprinkler tank	
				300 litres x 2 (158 gal)	

NOTE: Gradability is the calculated value. It may vary with ground surface conditions.

**SAKAI HEAVY INDUSTRIES, LTD.**

Head Office: 1-4-8, Shiba-Daimon, Minato-ku,  
Tokyo, Japan

Telephone: Tokyo (03) 3431-9971

Facsimile: (03) 3436-6212

SAKAI HEAVY INDUSTRIES, LTD.