

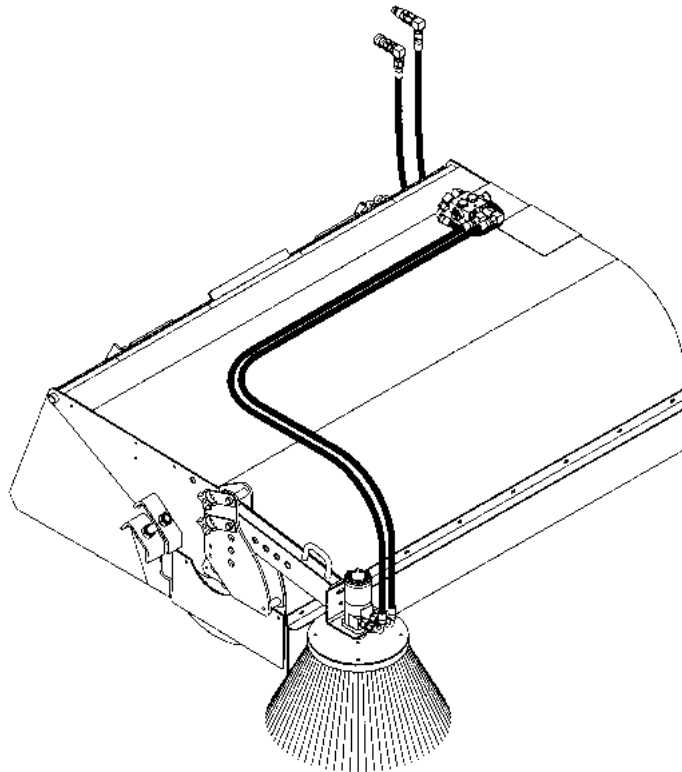

Bobcat®

Operation & Maintenance Manual



Sweeper

(54 Sweeper) S/N 782600101 & Above

(60 Sweeper) S/N 714400101 & Above

(72 Sweeper) S/N 783700101 & Above



CONTENTS

FOREWORD	3
SAFETY AND TRAINING RESOURCES	11
OPERATING INSTRUCTIONS	21
PREVENTIVE MAINTENANCE	93
MACHINE SIGN TRANSLATIONS	113
SPECIFICATIONS	119
WARRANTY	125
ALPHABETICAL INDEX	129

REFERENCE INFORMATION

Write the correct information for YOUR Bobcat attachment in the spaces below. Always use these numbers when referring to your Bobcat attachment.

Attachment Serial Number _____

NOTES:

YOUR BOBCAT DEALER:

ADDRESS:

PHONE:

Bobcat Company
P.O. Box 128
Gwinner, ND 58040-0128
UNITED STATES OF AMERICA

Doosan Bobcat EMEA s.r.o.
U Kodetky 1810
263 12 Dobris
CZECH REPUBLIC



Bobcat®

FOREWORD

This Operation & Maintenance Manual was written to give the owner / operator instructions on the safe operation and maintenance of the Bobcat attachment. READ AND UNDERSTAND THIS OPERATION & MAINTENANCE MANUAL BEFORE OPERATING YOUR BOBCAT ATTACHMENT. If you have any questions, see your Bobcat dealer. This manual may illustrate options and accessories not installed on your Bobcat attachment.

BOBCAT COMPANY IS ISO 9001 CERTIFIED	5
SERIAL NUMBER LOCATION	7
Attachment Serial Number	7
DELIVERY REPORT	7
ATTACHMENT IDENTIFICATION	8
Gutter Brush (Option)	9
FEATURES AND ACCESSORIES	10
Standard Items	10
Options And Accessories	10



Bobcat®

BOBCAT COMPANY IS ISO 9001 CERTIFIED



ISO 9001 is an international standard that specifies requirements for a quality management system that controls the processes and procedures which we use to design, develop, manufacture, and distribute Bobcat products.

British Standards Institute (**BSI**) is the Certified Registrar Bobcat Company chose to assess the company's compliance with the ISO 9001 at Bobcat's manufacturing facilities in Gwinner, North Dakota (U.S.A.), Pontchâteau (France), and the Bobcat corporate offices (Gwinner, Bismarck, and West Fargo) in North Dakota. **TÜV Rheinland** is the Certified Registrar Bobcat Company chose to assess the company's compliance with the ISO 9001 at Bobcat's manufacturing facility in Dobris (Czech Republic). Only certified assessors, like BSI and TÜV Rheinland, can grant registrations.

ISO 9001 means that as a company we say what we do and do what we say. In other words, we have established procedures and policies, and we provide evidence that the procedures and policies are followed.



Bobcat®

SERIAL NUMBER LOCATION

Attachment Serial Number

Always use the serial number of the sweeper when requesting service information or when ordering parts. Earlier or later models (identification made by serial number) may use different parts, or it may be necessary to use a different procedure in doing a specific service operation.

Figure 1

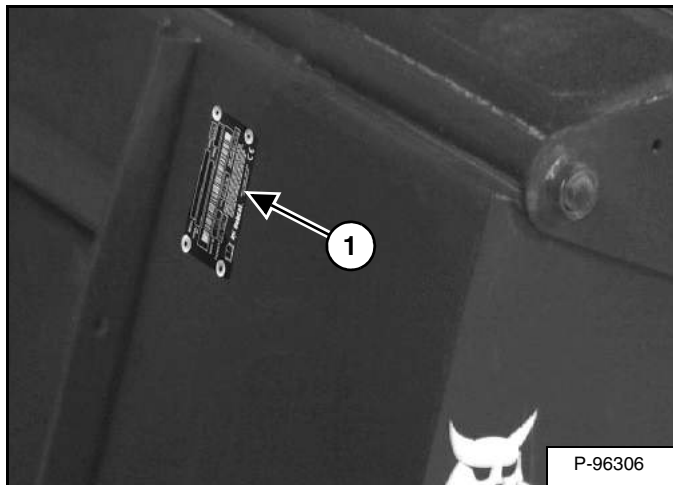

The serial number plate (Item 1) [Figure 1] is located at the front of the frame.

DELIVERY REPORT

Figure 2

The delivery report [Figure 2] contains a list of items that must be explained or shown to the owner or operator by the dealer when the Bobcat sweeper is delivered.

The delivery report must be reviewed and signed by the owner or operator and the dealer.

ATTACHMENT IDENTIFICATION

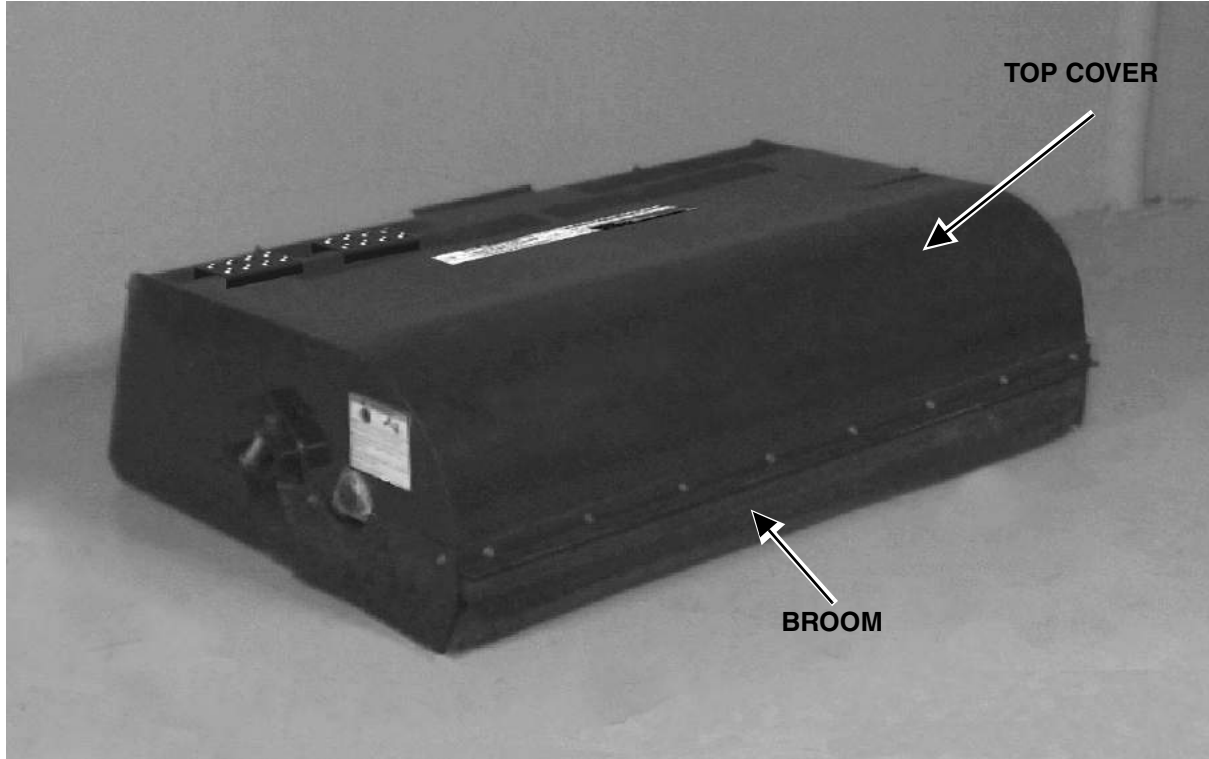

P105177

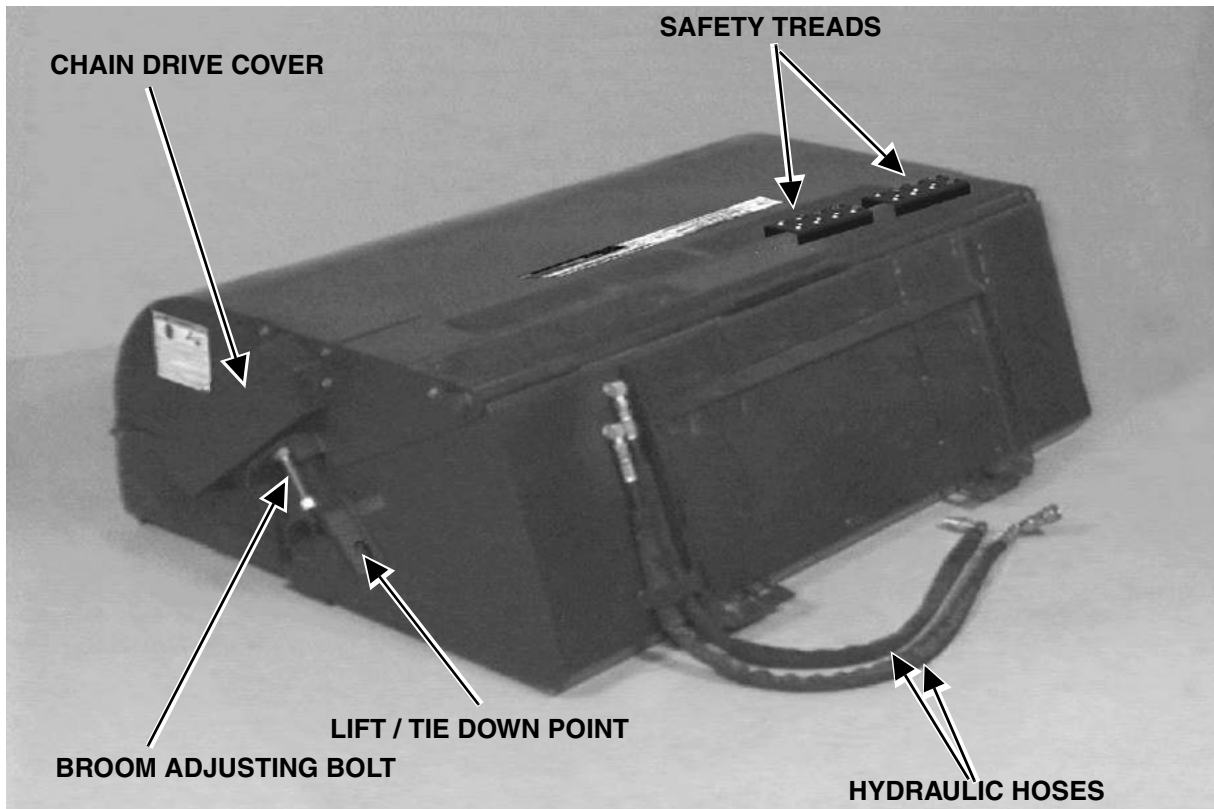

P105178A

ATTACHMENT IDENTIFICATION (CONT'D)

Gutter Brush (Option)

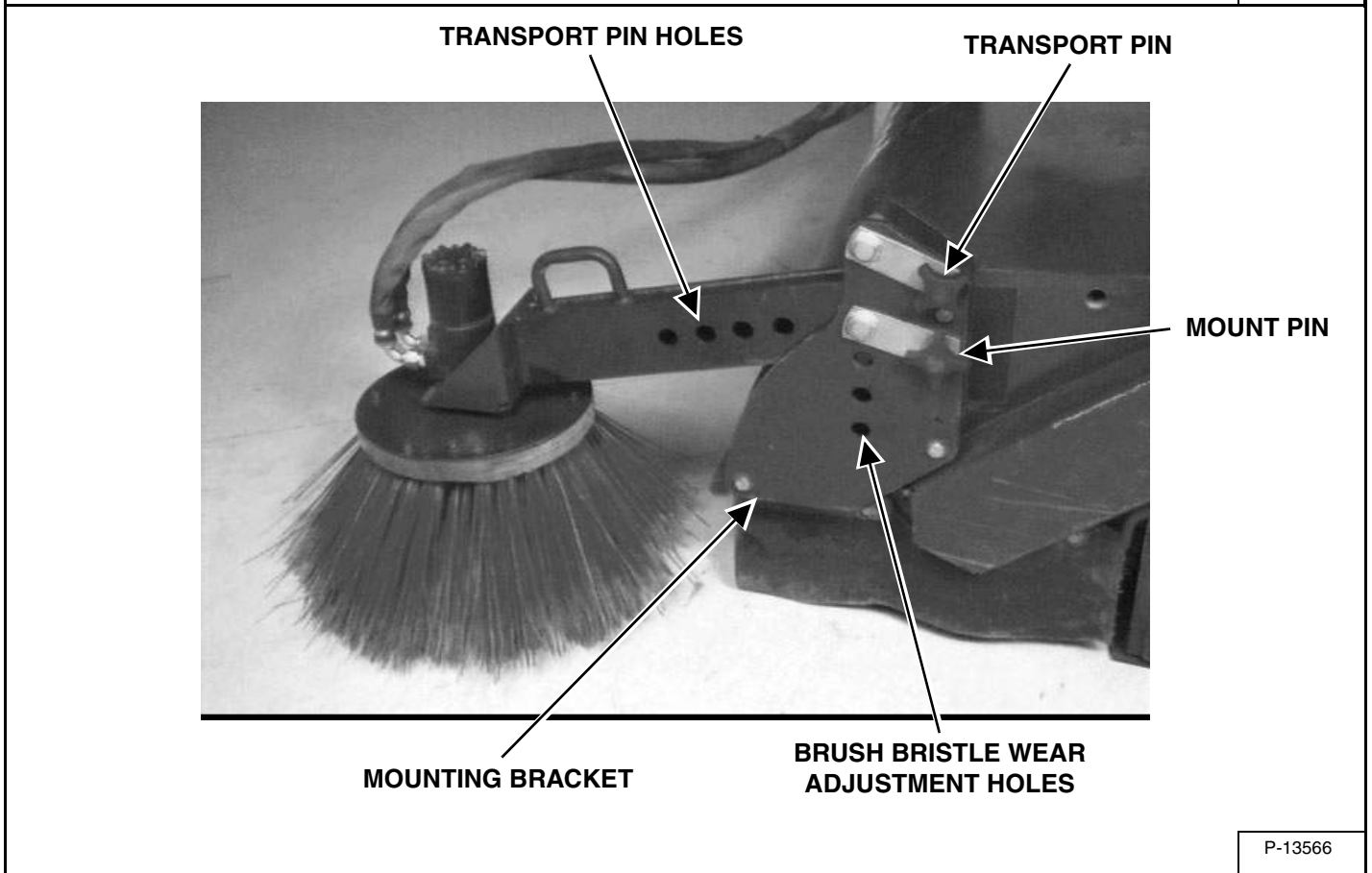
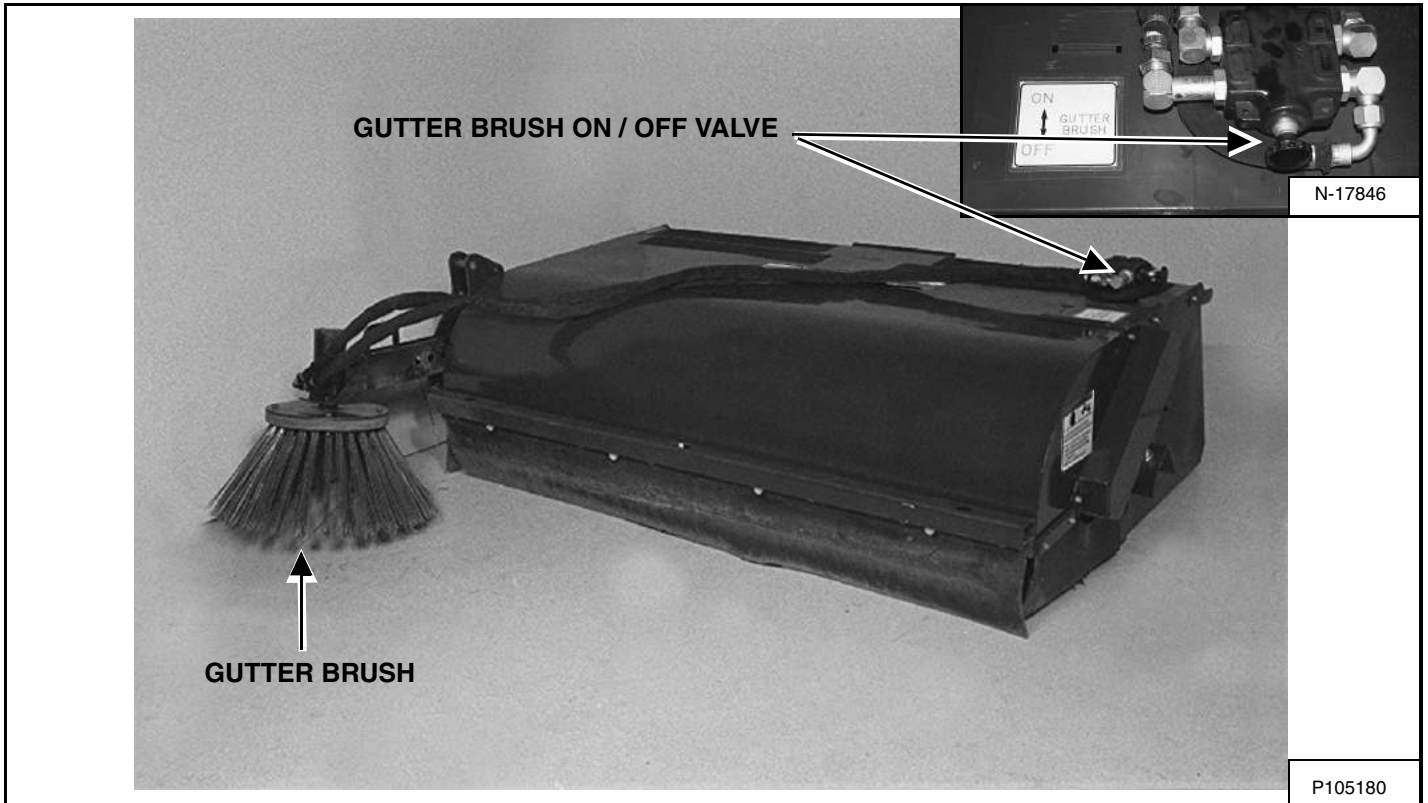

FEATURES AND ACCESSORIES

Standard Items

The sweeper is equipped with the following Standard items:

- Polypropylene Bristles
- Reversible Cutting Edge

Options And Accessories

Below is a list of Options and Accessories available for your sweeper. See your Bobcat dealer for other available options and accessories.

- Steel Bristles
- Gutter Brush
- Quick-Tach Water Kit
- Spray Nozzle Kit

SAFETY AND TRAINING RESOURCES

SAFETY INSTRUCTIONS	13
Safe Operation Is The Operator's Responsibility	13
Safe Operation Needs A Qualified Operator	13
Use Safety Rules	14
Call Before You Dig	14
Avoid Silica Dust	14
FIRE PREVENTION	15
Maintenance	15
Operation	15
Electrical	15
Hydraulic System	15
Fueling	15
Starting	15
Spark Arrester Exhaust System	15
Welding And Grinding	16
Fire Extinguishers	16
PUBLICATIONS AND TRAINING RESOURCES	17
ATTACHMENT SIGNS (DECALS)	18
Gutter Brush (Option)	19



Bobcat®

SAFETY INSTRUCTIONS

Safe Operation Is The Operator's Responsibility



Operator must have instructions before operating the machine. Untrained operators can cause injury or death.

W-2001-0502



This notice identifies procedures which must be followed to avoid damage to the machine.

I-2019-0284



The signal word **DANGER** on the machine and in the manuals indicates a hazardous situation which, if not avoided, will result in death or serious injury.

D-1002-1107



The signal word **WARNING** on the machine and in the manuals indicates a potentially hazardous situation which, if not avoided, could result in death or serious injury.

W-2044-1107

The Bobcat machine and attachment must be in good operating condition before use.

Check all of the items on the Bobcat Service Schedule Decal under the 8-10 hour column or as shown in the Operation & Maintenance Manual.

Safe Operation Needs A Qualified Operator

For an operator to be qualified, he or she must not use drugs or alcoholic drinks which impair alertness or coordination while working. An operator who is taking prescription drugs must get medical advice to determine if he or she can safely operate a machine and the attachment.

A Qualified Operator Must Do The Following:

Understand the Written Instructions, Rules and Regulations

- The written instructions from Bobcat Company include the Delivery Report, Operation & Maintenance Manual, Operator's Handbook, Safety Manual and machine signs (decals).
- Check the rules and regulations at your location. The rules may include an employer's work safety requirements. Regulations may apply to local driving requirements or use of a Slow Moving Vehicle (SMV) emblem. Regulations may identify a hazard such as a utility line.

Have Training with Actual Operation

- Operator training must consist of a demonstration and verbal instruction. This training is given by your Bobcat dealer before the product is delivered.
- The new operator must start in an area without bystanders and use all the controls until he or she can operate the machine and attachment safely under all conditions of the work area. Always fasten seat belt before operating.

Know the Work Conditions

- Know the weight of the materials being handled. Avoid exceeding the machine load capacities. Material which is very dense will be heavier than the same volume of less dense material. Reduce the size of load if handling dense material.
- The operator must know any prohibited uses or work areas, for example, he or she needs to know about excessive slopes.
- Know the location of any underground lines. Call local utilities or the TOLL FREE phone number found in the *Call Before You Dig* section of this manual.
- Wear tight fitting clothing. Always wear safety glasses when doing maintenance or service. Safety glasses, respiratory equipment, and hearing protection are required for some work. See your Bobcat dealer about Bobcat safety equipment for your machine.

SI ATT-0819

SAFETY INSTRUCTIONS (CONT'D)

Use Safety Rules

- Read and follow instructions in the machine and the attachment's Operation & Maintenance Manual before operating.
- Check for underground lines before operating attachment (if applicable).
- In addition to the design and configuration of equipment, hazard control and accident prevention are dependent upon the awareness, concern, prudence and proper training of personnel involved in the operation, transport, maintenance and storage of equipment.
- Check that the Bob-Tach® levers are in the locked position and the wedges are fully engaged into the holes of the attachment (if applicable).
- Check that the attachment is securely fastened to the machine.
- Make sure all the machine controls are in the NEUTRAL position before starting the machine.
- Operate the attachment only from the operator's position.
- Operate the attachment according to the Operation & Maintenance Manual.
- When learning to operate the attachment, do it at a slow rate in an area clear of bystanders.
- DO NOT permit personnel to be in the work area when operating the machine and attachment.
- The attachment must be used ONLY on approved machines. See your Bobcat dealer for updated list of approved attachments for each machine model.
- DO NOT modify equipment or add attachments that are not approved by the manufacturer.
- DO NOT make any adjustments or repairs on the machine or attachment while the engine is running.
- Keep shields and guards in place. Replace if damaged.

Call Before You Dig



Call Before You Dig Dial 811 (USA Only) 1-888-258-0808 (USA & Canada)

When you call, you will be directed to a location in your state / province, or city for information about buried lines (telephone, cable TV, water, sewer, gas, etc.).

Avoid Silica Dust

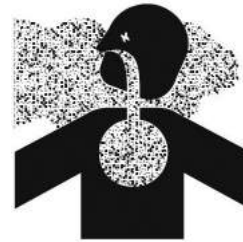

Cutting or drilling concrete containing sand or rock containing quartz may result in exposure to silica dust. Do not exceed Permissible Exposure Limits (PEL) to silica dust as determined by OSHA or other job site Rules and Regulations. Use a respirator, water spray or other means to control dust. Silica dust can cause lung disease and is known to the state of California to cause cancer.

SI ATT-0819

FIRE PREVENTION



Maintenance

The machine and some attachments have components that are at high temperatures under normal operating conditions. The primary source of high temperatures is the engine and exhaust system. The electrical system, if damaged or incorrectly maintained, can be a source of arcs or sparks.

Flammable debris (leaves, straw, etc.) must be removed regularly. If flammable debris is allowed to accumulate, it can cause a fire hazard. Clean often to avoid this accumulation. Flammable debris in the engine compartment is a potential fire hazard.

The operator's area, engine compartment and engine cooling system must be inspected every day and cleaned if necessary to prevent fire hazards and overheating.

All fuels, most lubricants and some coolant mixtures are flammable. Flammable fluids that are leaking or spilled onto hot surfaces or onto electrical components can cause a fire.

Operation

Do not use the machine where exhaust, arcs, sparks or hot components can contact flammable material, explosive dust or gases.

Electrical



Check all electrical wiring and connections for damage. Keep the battery terminals clean and tight. Repair or replace any damaged part or wires that are loose or frayed.

Battery gas can explode and cause serious injury. Use the procedure in the Operation & Maintenance Manual for connecting the battery and for jump starting. Do not jump start or charge a frozen or damaged battery. Keep any open flames or sparks away from batteries. Do not smoke in battery charging area.

Hydraulic System

Check hydraulic tubes, hoses and fittings for damage and leakage. Never use open flame or bare skin to check for leaks. Hydraulic tubes and hoses must be properly routed and have adequate support and secure clamps. Tighten or replace any parts that show leakage.

Always clean fluid spills. Do not use gasoline or diesel fuel for cleaning parts. Use commercial nonflammable solvents.

Fueling



Stop the engine and let it cool before adding fuel. No smoking! Do not refuel a machine near open flames or sparks. Fill the fuel tank outdoors.

Ultra Low Sulfur Diesel (ULSD) poses a greater static ignition hazard than earlier diesel formulations with higher Sulfur content. Avoid death or serious injury from fire or explosion. Consult with your fuel or fuel system supplier to ensure the delivery system is in compliance with fueling standards for proper grounding and bonding practices.

Starting

Do not use ether or starting fluids on any engine that has glow plugs. These starting aids can cause explosion and injure you or bystanders.

Use the procedure in the Operation & Maintenance Manual for connecting the battery and for jump starting.

Spark Arrester Exhaust System

The spark arrester exhaust system is designed to control the emission of hot particles from the engine and exhaust system, but the muffler and the exhaust gases are still hot.

Check the spark arrester exhaust system regularly to make sure it is maintained and working properly. Use the procedure in the Operation & Maintenance Manual for cleaning the spark arrester muffler (if equipped).

FIRE PREVENTION (CONT'D)

Welding And Grinding

Always clean the machine and attachment, disconnect the battery, and disconnect the wiring from the Bobcat controllers before welding. Cover rubber hoses, battery and all other flammable parts. Keep a fire extinguisher near the machine when welding.

Have good ventilation when grinding or welding painted parts. Wear dust mask when grinding painted parts. Toxic dust or gas can be produced.

Dust generated from repairing nonmetallic parts such as hoods, fenders or covers can be flammable or explosive. Repair such components in a well ventilated area away from open flames or sparks.

Fire Extinguishers

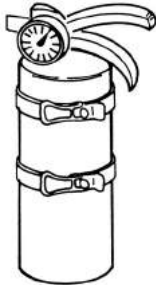

Know where fire extinguishers and first aid kits are located and how to use them. Inspect the fire extinguisher and service the fire extinguisher regularly. Obey the recommendations on the instructions plate.

PUBLICATIONS AND TRAINING RESOURCES

The following publications are also available for your Bobcat attachment. You can order from your Bobcat dealer.

For the latest information on Bobcat products and the Bobcat Company, visit our web site at **Bobcat.com**

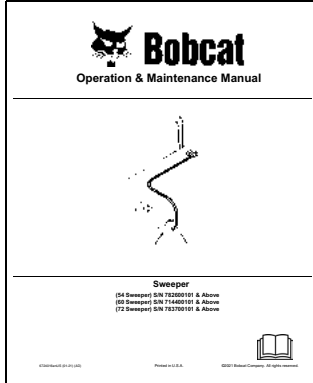

OPERATION & MAINTENANCE MANUAL

6724016enUS

Complete instructions on the correct operation and the routine maintenance of the Bobcat attachment.

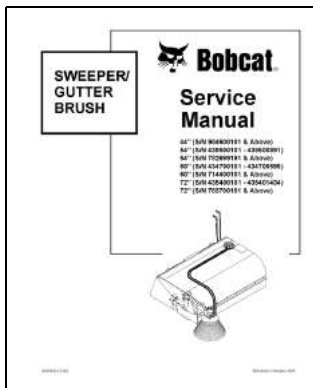

SERVICE MANUAL

6900898enUS

Complete maintenance and overhaul instructions for your Bobcat attachment.

ATTACHMENT SIGNS (DECALS)

Follow the instructions on all the Attachment Signs (Decals) that are on the attachment. Replace any damaged attachment signs and be sure they are in the correct locations. Attachment signs are available from your Bobcat attachment dealer.



6708822 (2)



7127607 (60 AND 72 SWEEPER)

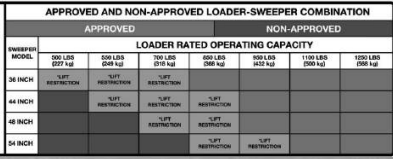

7141748 (54 SWEEPER ONLY)

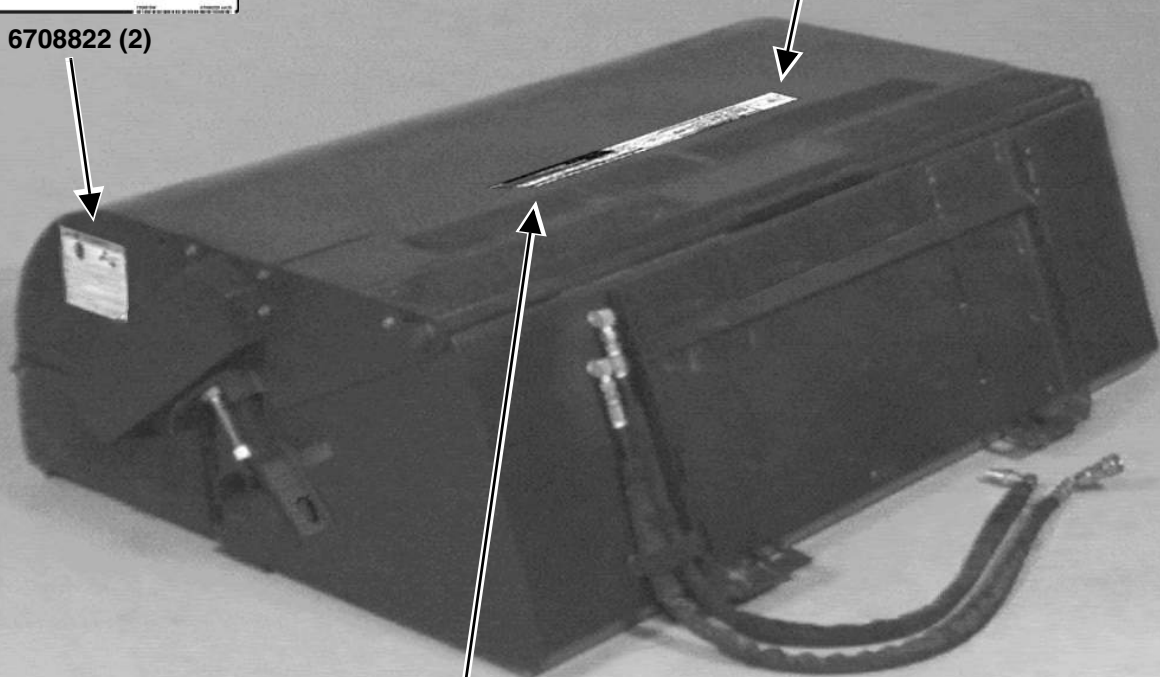

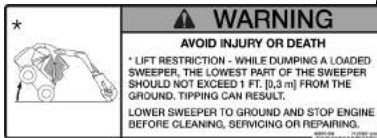

7127607 (60 AND 72 SWEEPER)

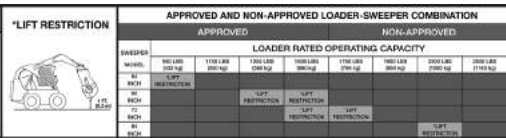

P105178

ATTACHMENT SIGNS (DECALS) (CONT'D)

Gutter Brush (Option)

Follow the instructions on all the Attachment Signs (Decals) that are on the attachment. Replace any damaged attachment signs and be sure they are in the correct locations. Attachment signs are available from your Bobcat attachment dealer.



P105180



Bobcat®

OPERATING INSTRUCTIONS

INITIAL SETUP	23
Gutter Brush	23
Hose Hanger Bracket	23
Removable Hose Guide	23
DAILY INSPECTION	24
Attachment Mounting Frame	24
Bob-Tach	25
VersaHANDLER Adapter Frame	27
OPERATING PROCEDURE WITH LOADERS	28
Approved Loader Models And Requirements	28
Machine / Attachment Setup	30
Entering And Exiting The Loader	34
Installation	35
Hydraulic Quick Couplers	43
Control Functions	44
Operation With The Loader	45
Removal	49
OPERATING PROCEDURE WITH VERSAHANDLERS	53
Approved VersaHANDLER Models And Requirements	53
Machine / Attachment Setup	54
Entering And Exiting The VersaHANDLER	55
Installation	56
Hydraulic Quick Couplers	60
Control Functions	61
Operation With The VersaHANDLER	62
Removal	67
OPERATING PROCEDURE WITH UTILITY WORK MACHINES	68
Approved Work Machine Models And Requirements	68
Machine / Attachment Setup	69
Entering And Exiting The Work Machine	71
Installation	72
Hydraulic Quick Couplers	81
Control Functions	82
Operation With The Work Machine	83
Removal	87
LIFTING THE ATTACHMENT	91
Procedure	91
TRANSPORTING THE ATTACHMENT ON A TRAILER	91
Fastening	91
TRANSPORTING THE ATTACHMENT AND MACHINE ON A TRAILER	92
Loading And Fastening	92



Bobcat®

INITIAL SETUP

Gutter Brush

NOTE: The gutter brush (if equipped) can be mounted on either side of the sweeper.

Figure 3

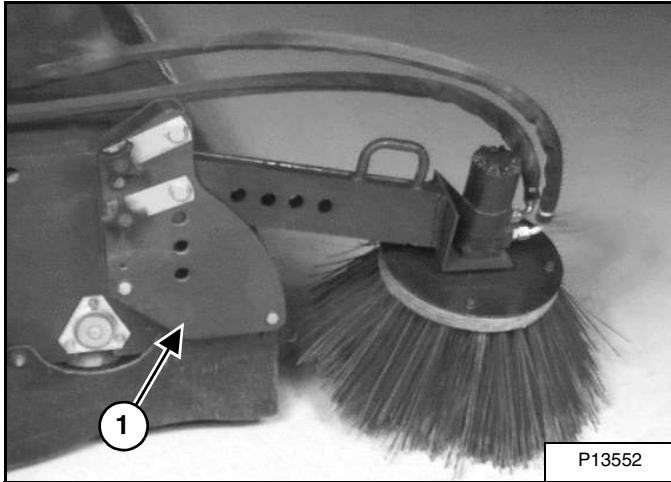

An extra mounting bracket (Item 1) [Figure 3] can be ordered from Bobcat Parts.

Figure 4

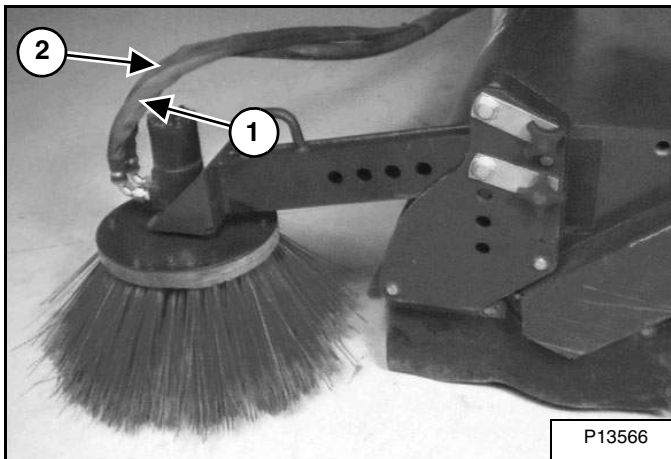

When the gutter brush is moved from the right side to the left side of the sweeper, the hydraulic hoses (Items 1 and 2) [Figure 4] must be switched for correct brush rotation.

Tighten the hose connections to 81 N•m (60 ft-lb) torque.

Hose Hanger Bracket

Figure 5

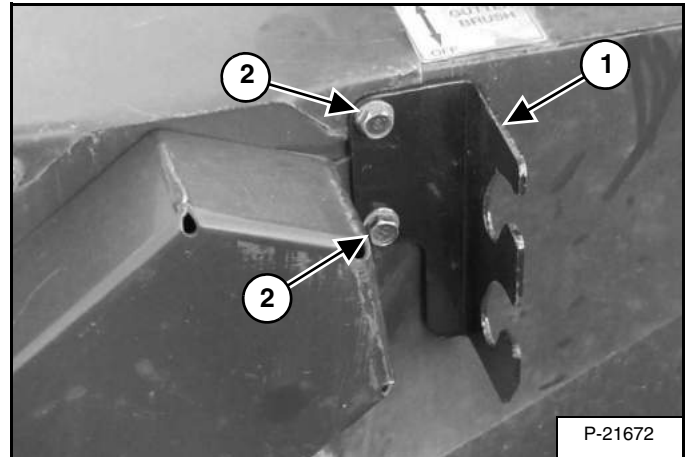

On some sweepers, the hose hanger bracket (Item 1) is not installed. The bracket will then be included in the shipping bag. Remove the two existing bolts (Item 2) and install the hose hanger bracket (Item 1) [Figure 5].

Removable Hose Guide

Figure 6

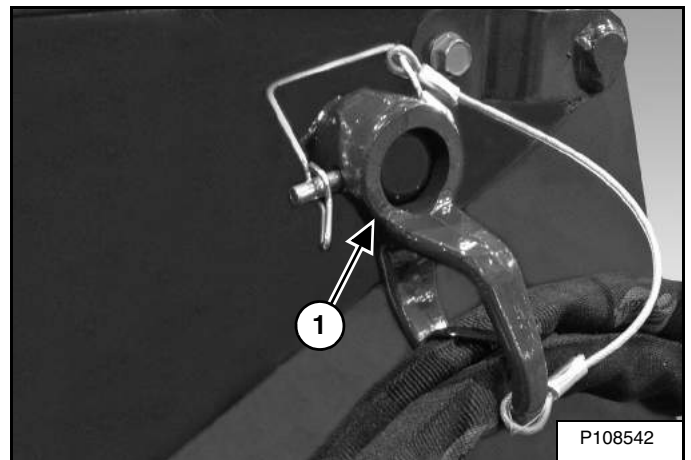

On some sweepers, the removable hose guide (if equipped) (Item 1) [Figure 6] is located on the left side of the sweeper.

DAILY INSPECTION

Attachment Mounting Frame

Figure 7

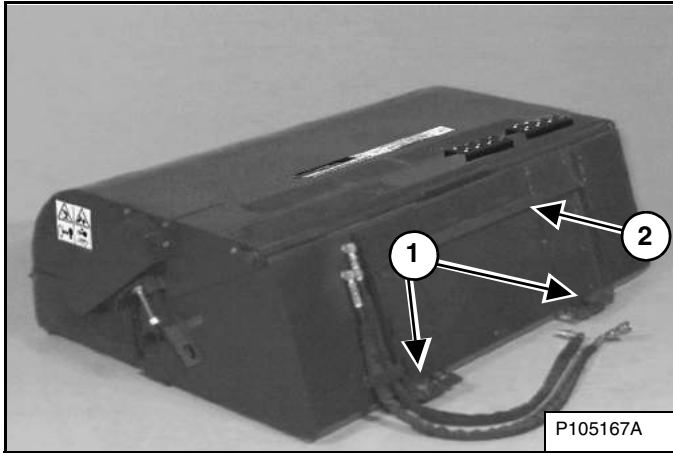

Inspect the Bob-Tach wedge mounts (Item 1), mounting flange (Item 2) **[Figure 7]** and all welds on the sweeper for wear and damage each time the sweeper is removed from the machine.

Frequently inspect the sweeper to ensure that all components are secure and that all bolts and nuts are thoroughly tightened.

DAILY INSPECTION (CONT'D)

Bob-Tach

Hand Lever Bob-Tach



AVOID INJURY OR DEATH

The Bob-Tach wedges must extend through the holes in the attachment mounting frame. Levers must be fully down and locked. Failure to secure wedges can allow attachment to come off.

W-2715-0208

Figure 8

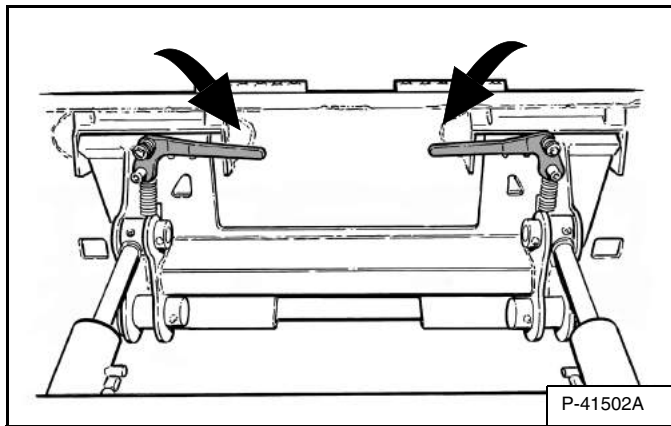

Push down on the Bob-Tach levers until they are fully engaged in the locked position [Figure 8] (wedges fully extended through the attachment mounting frame holes).

The levers and wedges must move freely [Figure 8].

Figure 9

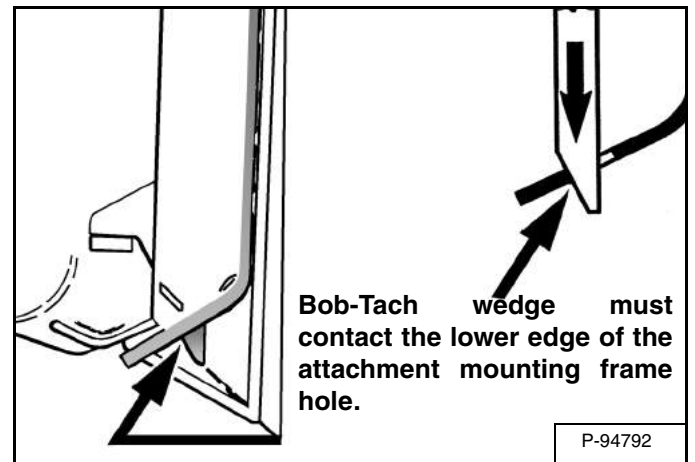

Bob-Tach wedge must contact the lower edge of the attachment mounting frame hole.

The wedges must extend through the holes in the attachment mounting frame, securely fastening the attachment to the Bob-Tach [Figure 9].

NOTE: If the wedge does not contact the lower edge of the hole, the attachment will be loose and can come off the Bob-Tach.

Inspect the mounting frame on the attachment. (See the machine's Operation & Maintenance Manual for inspecting the Bob-Tach). Replace any parts that are damaged, bent or missing. Keep all fasteners tight. Look for cracked welds. Contact your Bobcat dealer for repair or replacement parts.

Lubricate the wedges. (See the machine's Operation & Maintenance Manual for the correct procedure.)

DAILY INSPECTION (CONT'D)

Bob-Tach (Cont'd)

Power Bob-Tach



AVOID INJURY OR DEATH

The Bob-Tach wedges must extend through the holes in the attachment mounting frame. Levers must be fully down and locked. Failure to secure wedges can allow attachment to come off.

W-2715-0208

Figure 10

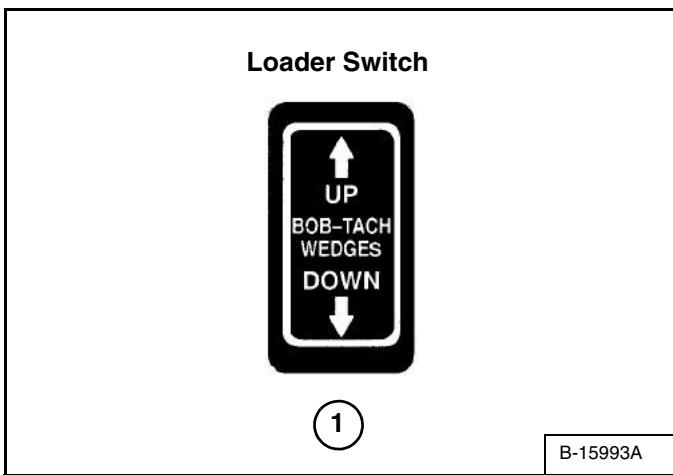

Figure 11

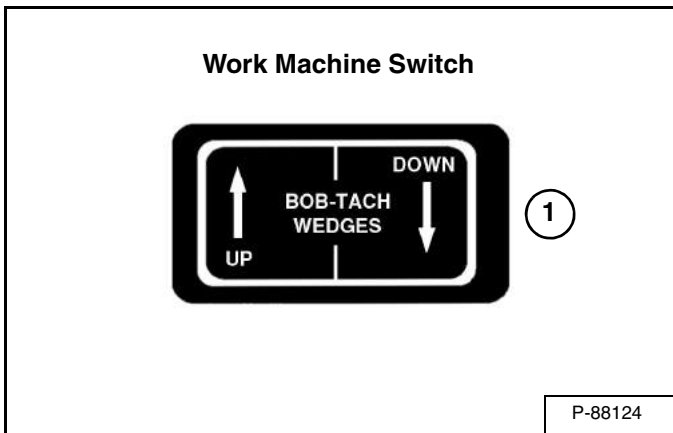
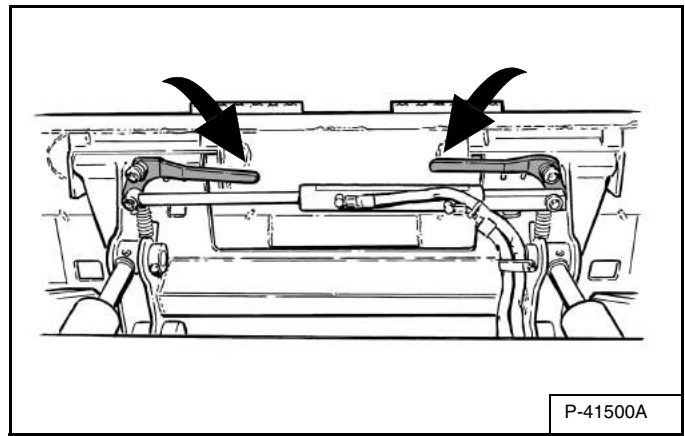
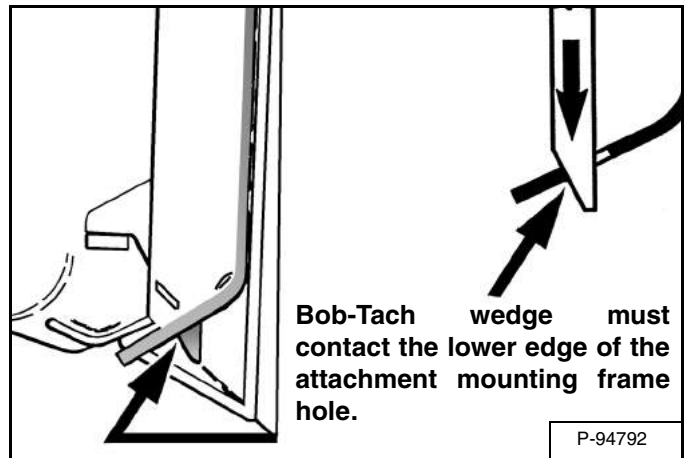

Figure 12



Push and hold the BOB-TACH “WEDGES DOWN” switch (Item 1) [Figure 10] and [Figure 11] until the levers are fully engaged in the locked position [Figure 12] (wedges fully extended through the attachment mounting frame holes).

Figure 13



The wedges must extend through the holes in the attachment mounting frame, securely fastening the attachment to the Bob-Tach [Figure 13].

NOTE: If the wedge does not contact the lower edge of the hole, the attachment will be loose and can come off the Bob-Tach.

Inspect the mounting frame on the attachment. (See the machine's Operation & Maintenance Manual for inspecting the Bob-Tach). Replace any parts that are damaged, bent or missing. Keep all fasteners tight. Look for cracked welds. Contact your Bobcat dealer for repair or replacement parts.

Lubricate the wedges. (See the machine's Operation & Maintenance Manual for the correct procedure.)

DAILY INSPECTION (CONT'D)

VersaHANDLER Adapter Frame

Figure 14

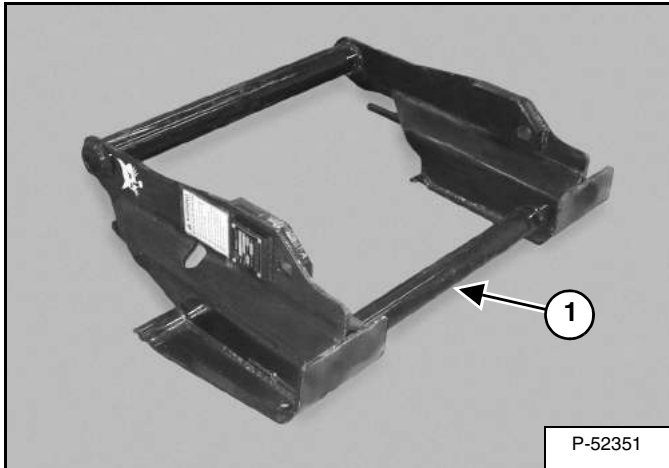

Inspect the adapter frame (Item 1) [Figure 14] and all welds on the attachment mount for wear and damage each time the attachment is removed from the VersaHANDLER.

Repair or replace damaged parts.

OPERATING PROCEDURE WITH LOADERS

Approved Loader Models And Requirements

Figure 15

LOADER MODEL	*54 SWEEPER	*60 SWEEPER	72 SWEEPER
553	X		
751	X	X	
753	X	X	
763		X	
773		X	X
863		X	X
864		X	X
873			X
963			X
A300			X
A770			X+
S100	X		
S130	X	X	
S150		X	X
S160		X	X
S175		X	X
S185		X	X
S205		X	X
S220			X+
S250			X+
S300			X+
S330			X+
S450		X	
S510		X	X
S530		X	X
S550		X	X
S570		X	X
S590		X	X
S595		X	X+
S630			X+
S650			X+
S740			X+
S750			X+
S770			X+
S62		X	X+
S64		X	X+
S66		X	X+
S76			X+
T110	X		
T140	X	X	
T180		X	
T190		X	X
T450		X	
T550		X	X
T590		X	X
T595		X	X+
T630			X+
T650			X+
T62		X	X+
T64		X	X+
T66		X	X+
T76			X+

X = Approved

* These sweeper models are not supplied with a removable hose guide.

+ These sweeper / loader combinations are approved to use the removable hose guide. If your combination is not approved, remove the hose guide from the hoses. See your Bobcat dealer for available hose guide kits.

The chart [Figure 15] shows the approved sweeper models for each loader model.



Never use attachments or buckets which are not approved by the Bobcat Company. Attachments and buckets for safe loads of specified densities are approved for each model. Unapproved attachments and buckets can cause injury or death.

W-2662-0108

OPERATING PROCEDURE WITH LOADERS (CONT'D)

Approved Loader Models And Requirements (Cont'd)

Figure 16

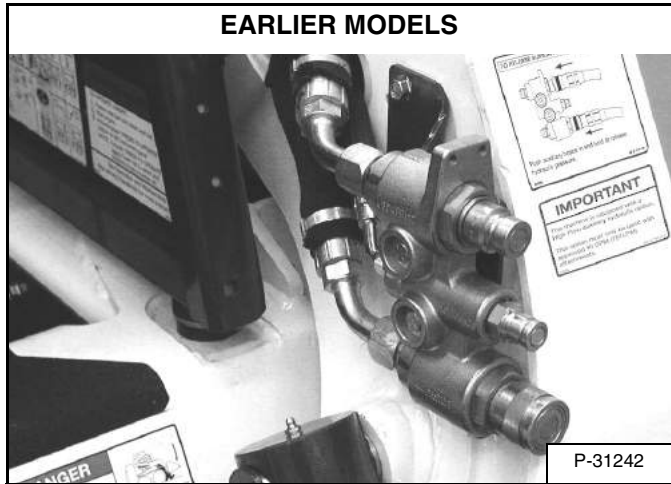
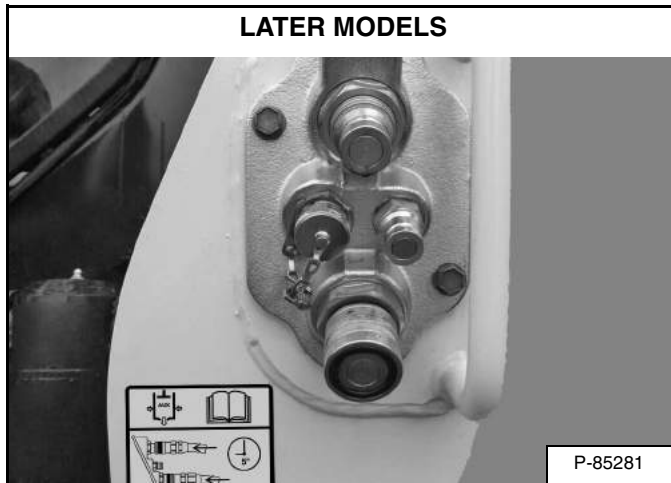

Figure 17



The loader must be equipped with front auxiliary hydraulics [Figure 16] or [Figure 17] for proper operation of the sweeper. See your Bobcat Loader dealer for available kits for your model loader.

The warranty is void if this attachment is used on a non-approved carrier. See your Bobcat dealer for an updated list of approved carriers.

OPERATING PROCEDURE WITH LOADERS (CONT'D)

Machine / Attachment Setup

Quick-Tach Water Kit

Quick-Tach Water kits are available and are rear mounted on the loaders and provide water to the Spray Nozzle kit.

Figure 18

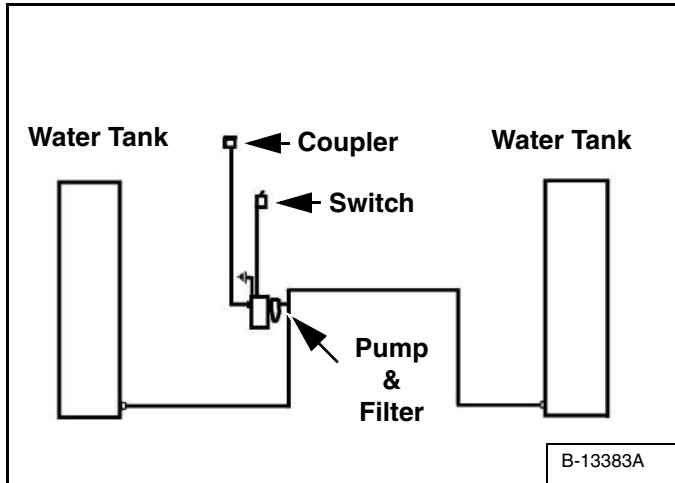

The illustration shows a typical arrangement and routing of the water kits [Figure 18].

See your Bobcat dealer for available water kits.

Spray Nozzle Kit

The Spray Nozzle kit helps control dust when the sweeper is mounted on the loader. See your Bobcat dealer for available spray kits.

Use the following procedure to install the nozzles on the sweeper:



AVOID INJURY OR DEATH
Wear safety goggles to prevent eye injury when drilling or grinding.

W-2108-1186

Figure 19

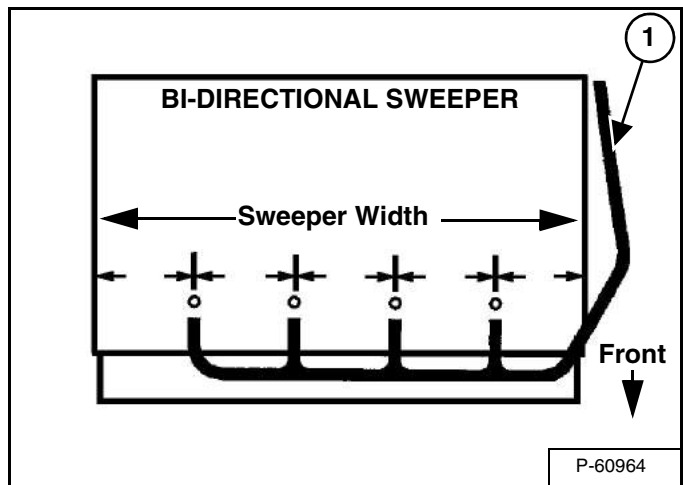

Install the four fittings and nozzles in the pre-drilled holes [Figure 19].

NOTE: Install the nozzles so the spray is directed parallel with the brush working surface.

Cut the hose to fit between the fittings, clamp the hoses in place.

Install the remaining hose (Item 1) [Figure 19] on the left fitting and cut the length to reach the lift arm coupler.

Install the adapter on the hose, clamp the hose and install the coupler on the adapter.

Use the cable tie to hold the long section of the hose to prevent the hose from breaking or wearing against the attachment.

OPERATING PROCEDURE WITH LOADERS (CONT'D)

Machine / Attachment Setup (Cont'd)

Hose Guide Installation (Earlier Version)

Figure 20

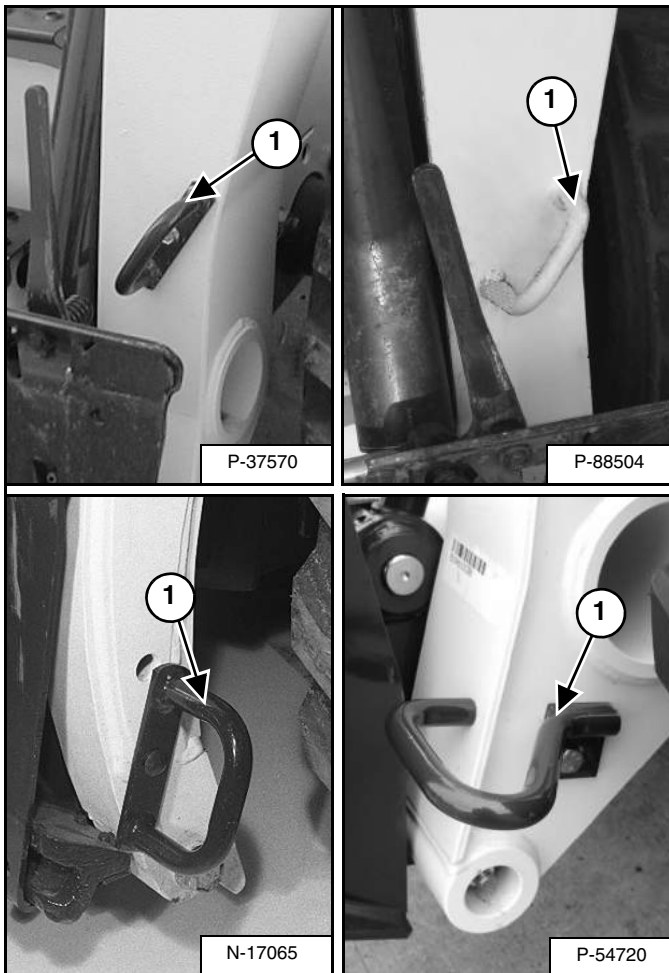

Install the correct hose guide (Item 1) [Figure 20] on the loader.

NOTE: Hose guide styles vary between loader models. Hose guides are not included with the attachment. See your Bobcat dealer for available hose guide kits.

Hose Guide Installation (Model 873)

Figure 21

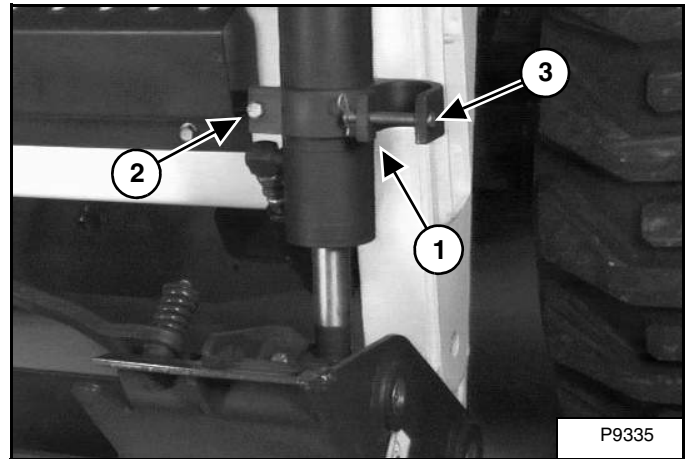

Install the hose clamp (Item 1) [Figure 21] over the tilt cylinder rod and slide the clamp onto the cylinder housing.

Install the bolt (Item 2) [Figure 21] and nut and tighten.

Install the clevis pin (Item 3) [Figure 21] and cotter pin.

Hose Guide Installation (Model 963)

Figure 22

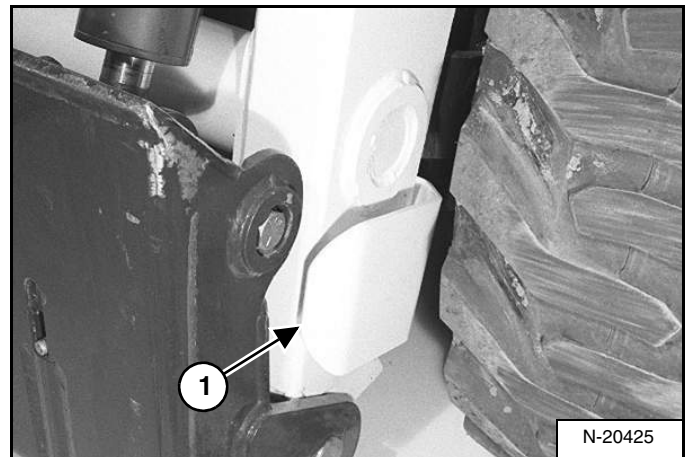

Install the hose guide (Item 1) [Figure 22].

OPERATING PROCEDURE WITH LOADERS (CONT'D)

Machine / Attachment Setup (Cont'd)

Hose Guide Installation (Removable - If Equipped)

Figure 23

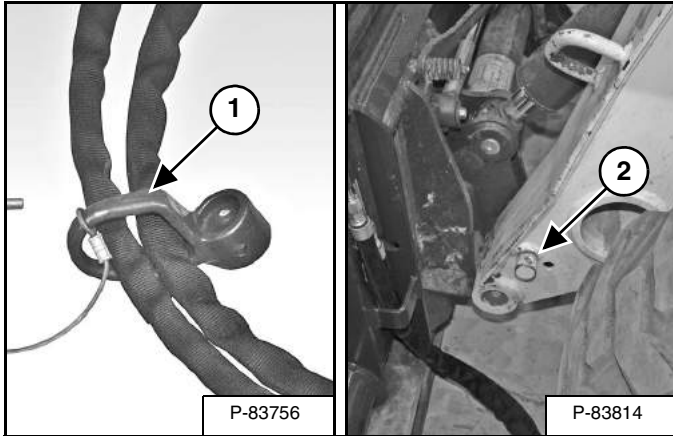

NOTE: Some attachments are factory equipped with a removable hose guide (Item 1) installed on the hydraulic hoses. The removable hose guide is factory installed for use with Bobcat loaders equipped with a mounting post (Item 2) [Figure 23]. Removable hose guide and mounting post kits are available through your Bobcat dealer.

Installation of removable hose guide is done during hose routing. (See Hose Routing (Removable - If Equipped) on Page 40.)

Figure 24

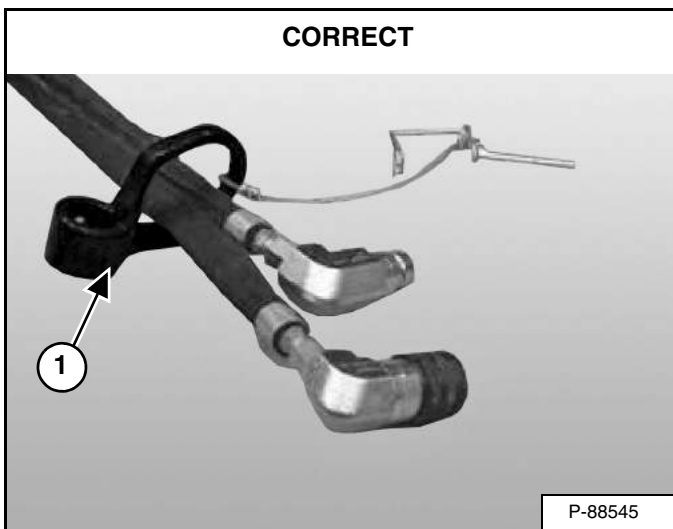

Shown is the removable hose guide (Item 1) [Figure 24] correct orientation for a loader.

NOTE: The removable hose guide orientation may need to be changed for correct installation onto the loader.

Figure 25

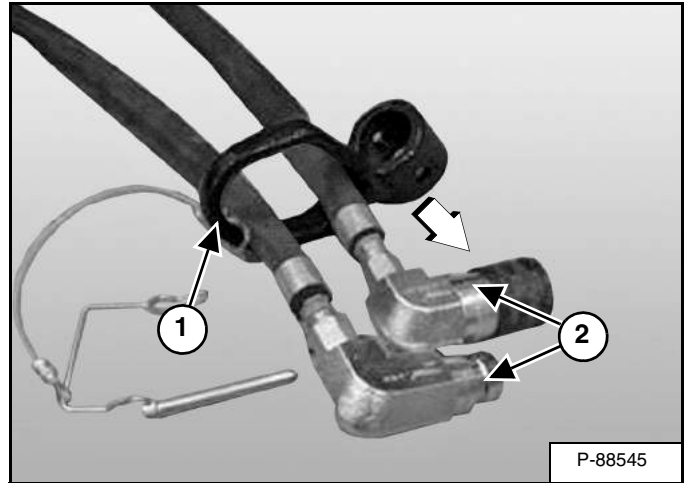

To change the removable hose guide (Item 1) [Figure 25] orientation, slide the removable hose guide off the hoses.

NOTE: It may be necessary to remove the hose couplers (Item 2) [Figure 25].

Figure 26

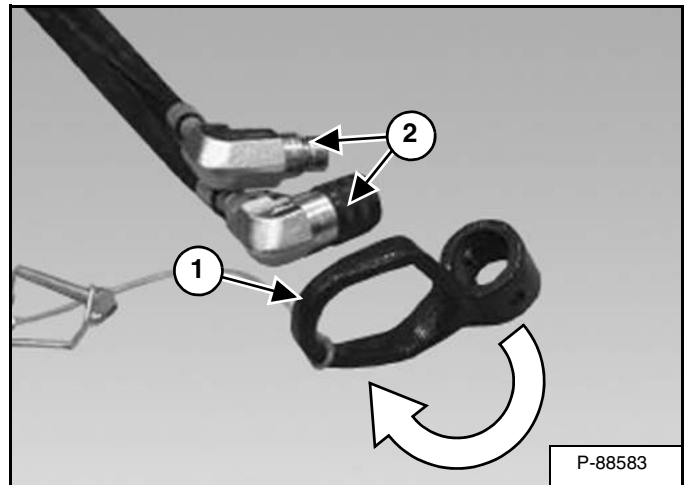

Flip the removable hose guide (Item 1) over to reverse its orientation on the hoses (Item 2) [Figure 26].

OPERATING PROCEDURE WITH LOADERS (CONT'D)

Machine / Attachment Setup (Cont'd)

Hose Guide Installation (Removable - If Equipped) (Cont'd)

Figure 27

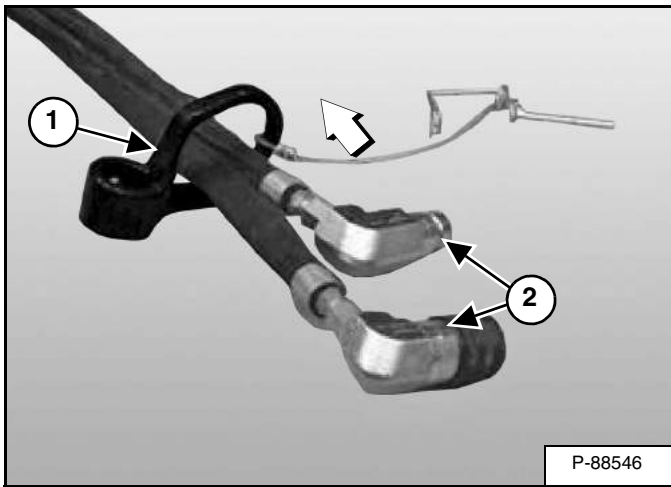

Slide the removable hose guide (Item 1) [Figure 27] back onto the hoses.

NOTE: If the couplers (Item 2) [Figure 27] were removed, reinstall at this time.

OPERATING PROCEDURE WITH LOADERS (CONT'D)

Entering And Exiting The Loader

Entering

! WARNING

AVOID INJURY OR DEATH

When operating the machine:

- Keep the seat belt fastened snugly.
- The seat bar must be lowered.
- Keep your feet on the pedal controls or footrests and hands on the controls.

W-2261-0909

Figure 28



Use the attachment steps, grab handles and safety treads (on the loader lift arms and frame) to get on and off the loader [Figure 28].

Figure 29



Enter the loader. Fasten the seat belt and adjust it so the buckle is centered between your hips [Figure 29].

Figure 30



Lower the seat bar and engage the parking brake [Figure 30].

Put the foot pedals or hand controls in NEUTRAL position.

NOTE: Keep your hands on the steering levers and your feet on the foot pedals (or footrests) while operating the loader.

See the loader's Operation & Maintenance Manual and Operator's Handbook for detailed information on operating the loader.

Exiting

Lower the lift arms and put the attachment flat on the ground.

Stop the engine and engage the parking brake.

Lift the seat bar and make sure the lift and tilt functions are deactivated.

Remove the key.

Exit the loader.

! WARNING

AVOID INJURY OR DEATH

Before you leave the operator's position:

- Lower the lift arms, put the attachment flat on the ground.
- Stop the engine and engage the parking brake.
- Move all pedals, handles, joysticks, and other controls until they are LOCKED or in the NEUTRAL position.

SEE THE MACHINE OPERATION & MAINTENANCE MANUAL FOR MORE INFORMATION.

W-2722-0208

OPERATING PROCEDURE WITH LOADERS (CONT'D)

Installation

Hand Lever Bob-Tach

NOTE: The illustrations and instructions provided explain how to install a bucket attachment on to a loader. Follow these same instructions if you are installing different attachments such as a grapple, tiller, combo bucket, etc.

The attachment mounting frame for the attachment has a top flange that is designed to receive the top edge of the Bob-Tach and the lower part of the frame is designed to receive the Bob-Tach wedges.



Warnings on the machine and in the manuals are for your safety. Failure to obey warnings can cause serious injury or death.

W-2744-0608

Always inspect the loader's Bob-Tach and the attachment mounting frame before installation. See the loader's Operation & Maintenance Manual. (See DAILY INSPECTION on Page 24.)

Figure 31

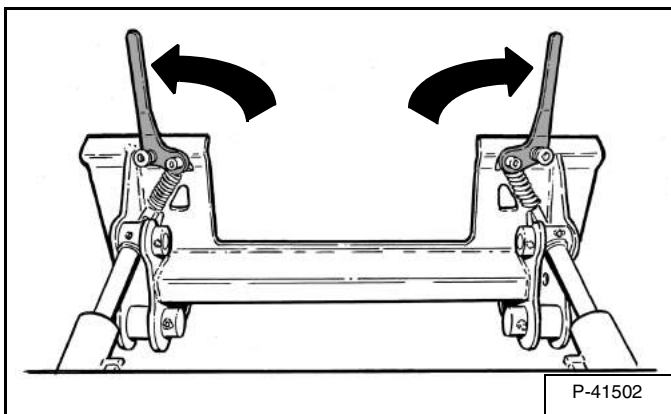

Pull the Bob-Tach levers up until they are fully raised (wedges fully raised) [Figure 31].

Enter the loader. (See Entering And Exiting The Loader on Page 34.)

Start the engine, press the PRESS TO OPERATE LOADER button and release the parking brake.

Figure 32

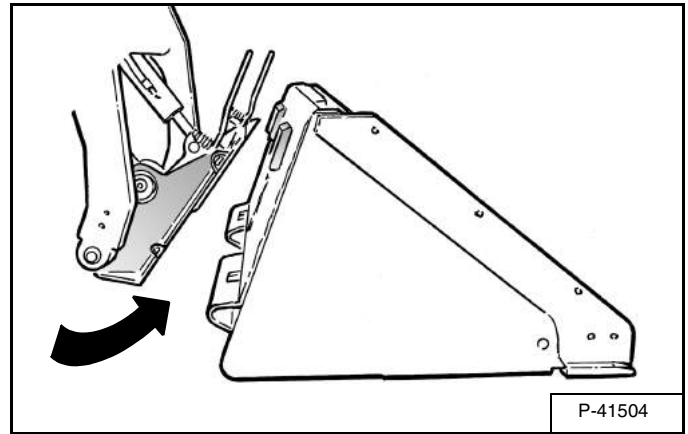

Lower the lift arms and tilt the Bob-Tach forward.

Drive the loader slowly forward until the top edge of the Bob-Tach is completely under the top flange of the attachment mounting frame [Figure 32].

NOTE: Be sure the Bob-Tach levers do not hit the attachment.

Figure 33

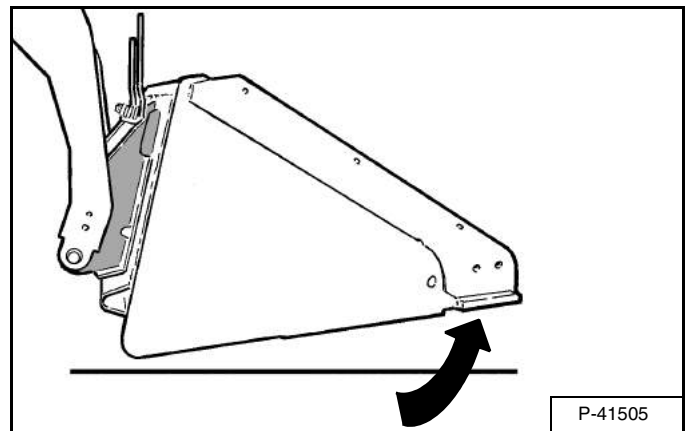

Tilt the Bob-Tach backward until the attachment is slightly off the ground [Figure 33]. This will cause the attachment mounting frame to fit up against the front of the Bob-Tach.

NOTE: When leaving the operator's seat to install an attachment, tilt the attachment until it is slightly off the ground.

Stop the engine and exit the loader. (See Entering And Exiting The Loader on Page 34.)

OPERATING PROCEDURE WITH LOADERS (CONT'D)

Installation (Cont'd)

Hand Lever Bob-Tach (Cont'd)

! WARNING

AVOID INJURY OR DEATH

Before you leave the operator's seat:

- Lower the lift arms and put the attachment flat on the ground.
- Stop the engine.
- Engage the parking brake.
- Raise the seat bar.
- Move all controls to the **NEUTRAL / LOCKED** position to make sure the lift, tilt and traction drive functions are deactivated.

The seat bar system must deactivate these functions when the seat bar is up. See your Bobcat dealer for service if controls do not deactivate.

W-2463-1110

Figure 34

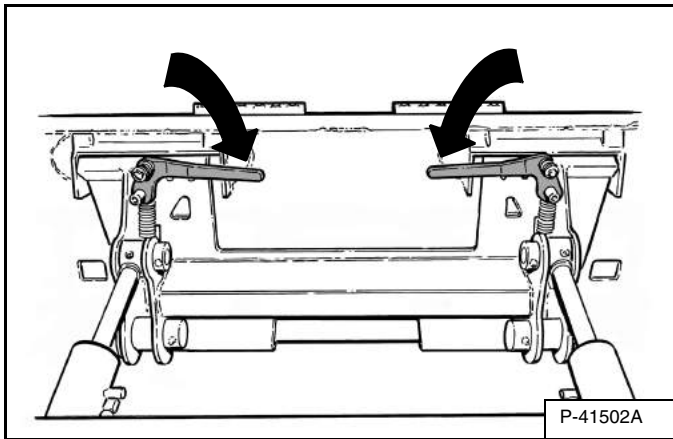

Push down on the Bob-Tach levers until they are fully engaged in the locked position [Figure 34] (wedges fully extended through the attachment mounting frame holes).

Figure 35

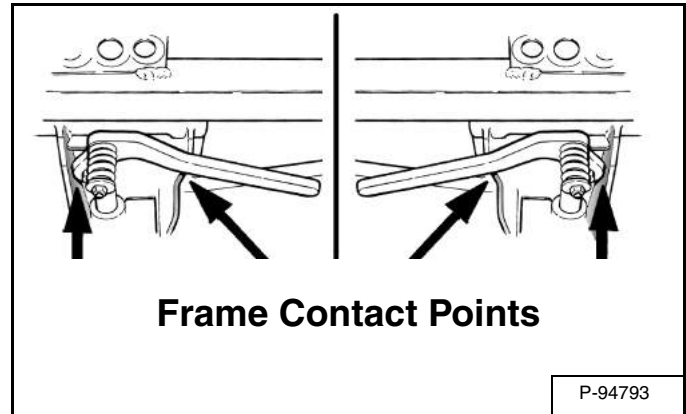

Both levers must contact the frame as shown when locked [Figure 35].

If both levers do not engage in the locked position, see your Bobcat dealer for maintenance.

! WARNING

AVOID INJURY OR DEATH

The Bob-Tach wedges must extend through the holes in the attachment mounting frame. Levers must be fully down and locked. Failure to secure wedges can allow attachment to come off.

W-2715-0208

Figure 36

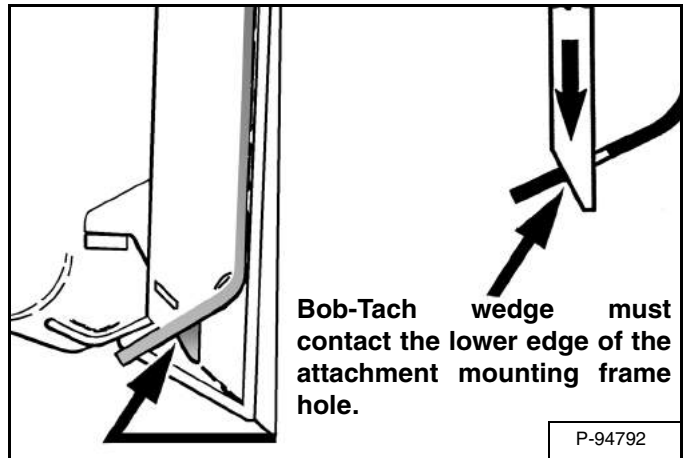

The wedges must extend through the holes in the attachment mounting frame, securely fastening the attachment to the Bob-Tach [Figure 36].

OPERATING PROCEDURE WITH LOADERS (CONT'D)

Installation (Cont'd)

Power Bob-Tach



Warnings on the machine and in the manuals are for your safety. Failure to obey warnings can cause serious injury or death.

W-2744-0608

This loader may be equipped with a Power Bob-Tach.

Enter the loader. (See Entering And Exiting The Loader on Page 34.)

Start the engine, press the PRESS TO OPERATE LOADER button and release the parking brake.

Figure 37

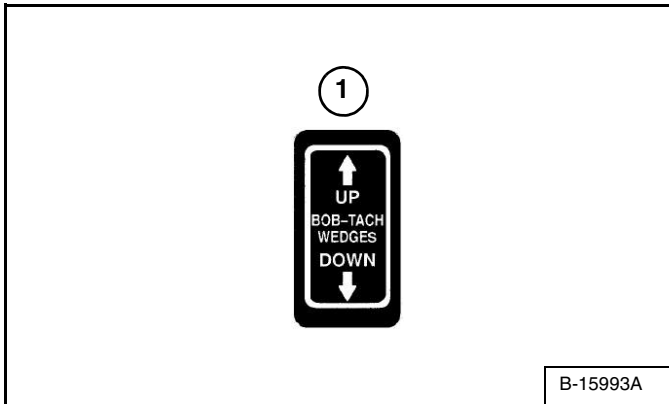
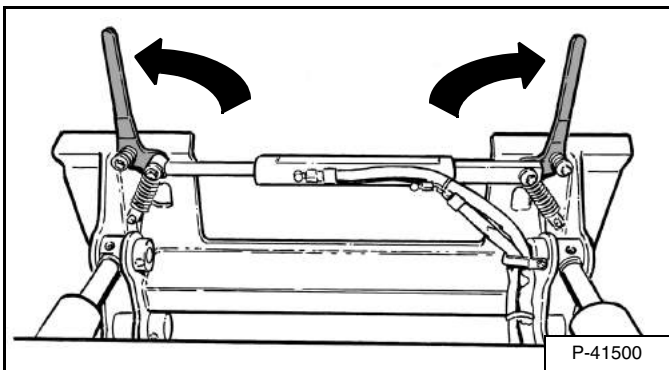

Figure 38



Push and hold the BOB-TACH “WEDGES UP” switch (Item 1) [Figure 37] until the levers are fully raised (wedges fully raised) [Figure 38].

Lower the lift arms and tilt the Bob-Tach slightly forward.

Drive the loader slowly forward until the top edge of the Bob-Tach is completely under the top flange of the attachment mounting frame [Figure 38].

NOTE: Be sure the Bob-Tach levers do not hit the attachment.

Figure 39

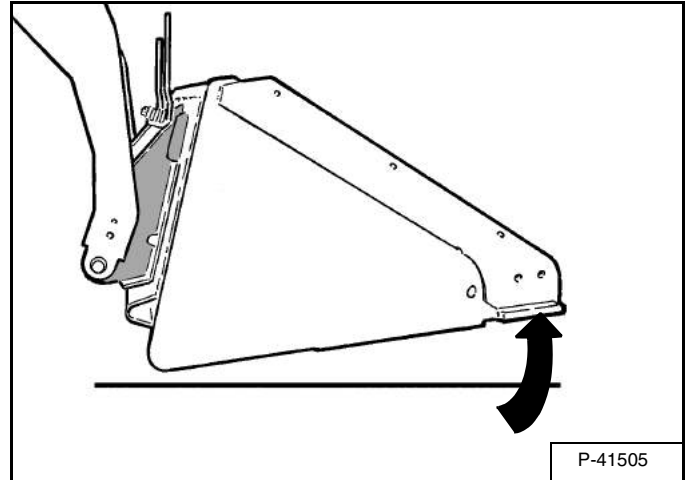

Tilt the Bob-Tach backward until the attachment is slightly off the ground [Figure 39]. This will cause the attachment mounting frame to fit up against the front of the Bob-Tach.

OPERATING PROCEDURE WITH LOADERS (CONT'D)

Installation (Cont'd)

Power Bob-Tach (Cont'd)

Figure 40

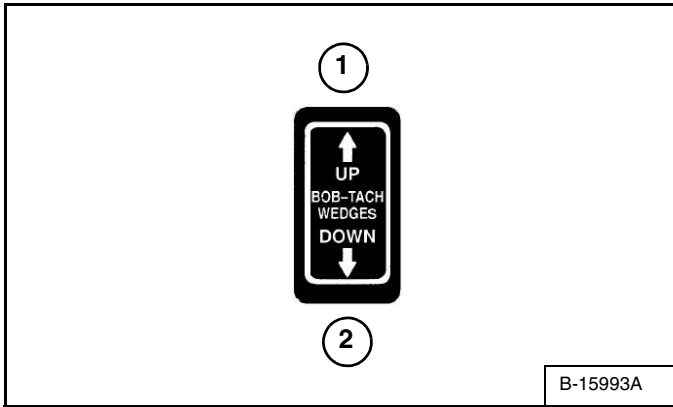

NOTE: The Power Bob-Tach system has continuous pressurized hydraulic oil to keep the wedges in the engaged position and prevent attachment disengagement. Because the wedges can slowly lower, the operator may need to reactivate the switch (BOB-TACH “WEDGES UP”) to be sure both wedges are fully raised before installing the attachment.

Push and hold the BOB-TACH “WEDGES UP” switch (Item 1) [Figure 40] until the levers are fully raised (wedges fully raised).

Figure 41

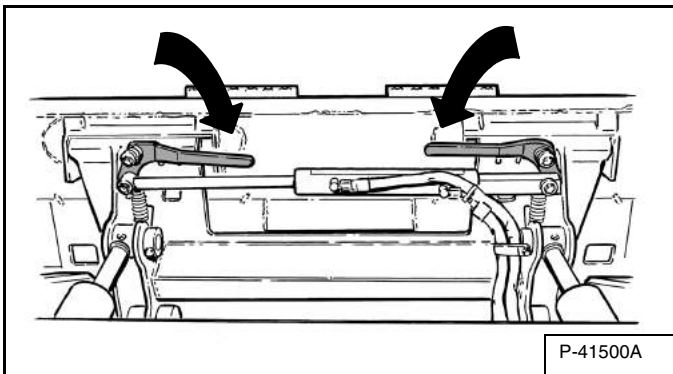

Push and hold the BOB-TACH “WEDGES DOWN” switch (Item 2) [Figure 40] until the levers are fully engaged in the locked position [Figure 41] (wedges fully extended through the attachment mounting frame holes).

Figure 42

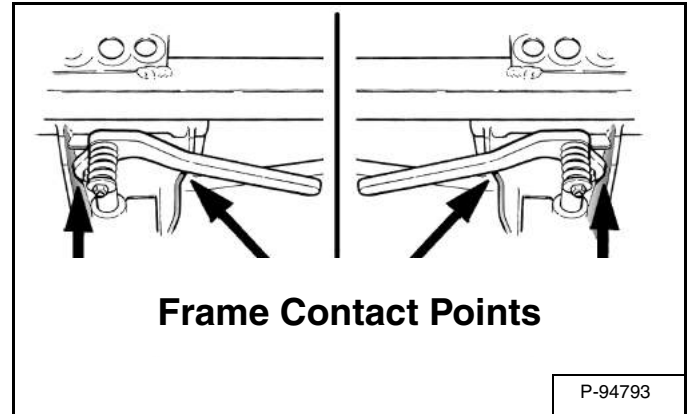

Both levers must contact the frame as shown when locked [Figure 42].

If both levers do not engage in the locked position, see your Bobcat dealer for maintenance.

! WARNING

AVOID INJURY OR DEATH

The Bob-Tach wedges must extend through the holes in the attachment mounting frame. Levers must be fully down and locked. Failure to secure wedges can allow attachment to come off.

W-2715-0208

Figure 43

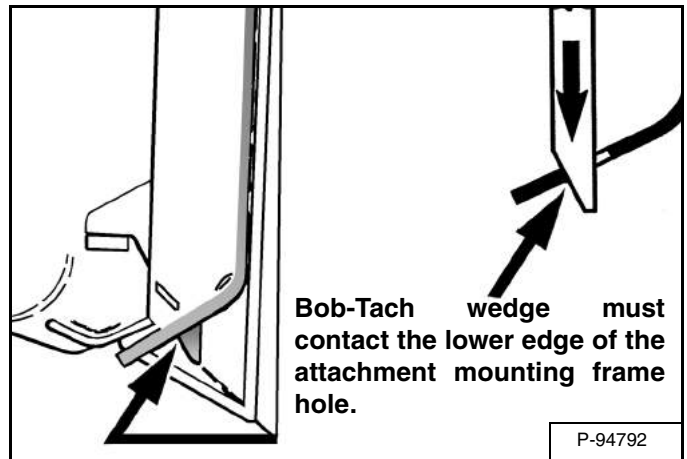

The wedges must extend through the holes in the attachment mounting frame, securely fastening the attachment to the Bob-Tach [Figure 43].

Lower the lift arms and put the attachment flat on the ground.

OPERATING PROCEDURE WITH LOADERS (CONT'D)

Installation (Cont'd)

Power Bob-Tach (Cont'd)

Stop the engine and exit the loader. (See Entering And Exiting The Loader on Page 34.)



AVOID INJURY OR DEATH

Before you leave the operator's seat:

- Lower the lift arms and put the attachment flat on the ground.
- Stop the engine.
- Engage the parking brake.
- Raise the seat bar.
- Move all controls to the **NEUTRAL / LOCKED** position to make sure the lift, tilt and traction drive functions are deactivated.

The seat bar system must deactivate these functions when the seat bar is up. See your Bobcat dealer for service if controls do not deactivate.

W-2463-1110

OPERATING PROCEDURE WITH LOADERS (CONT'D)

Installation (Cont'd)

Hose Routing (Earlier Version)

Figure 44

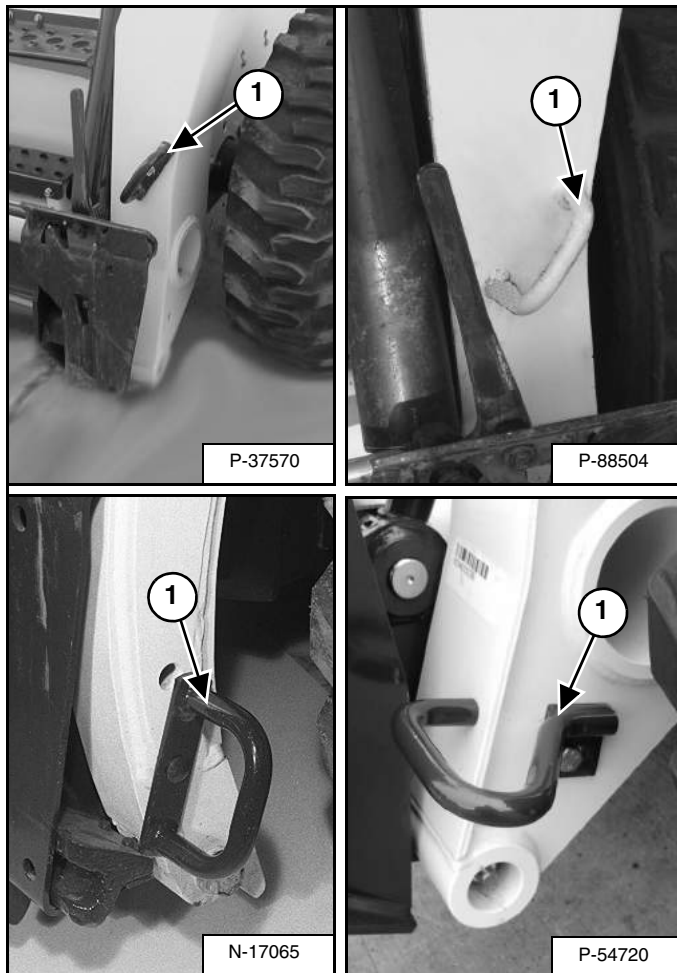

Route hoses through hose guide (Item 1) [Figure 44] and connect quick couplers to the loader. (See Hydraulic Quick Couplers on Page 43.)

NOTE: Hose guide styles vary between loader models. Hose guides are not included with the attachment. See your Bobcat dealer for available hose guide kits.

Hose Routing (Removable - If Equipped)

Figure 45

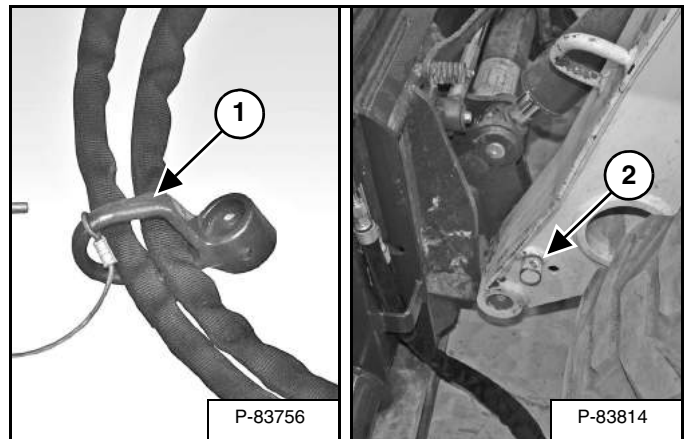

NOTE: Some attachments include removable hose guide (Item 1) for use on loaders equipped with a mounting post (Item 2) [Figure 45]. Removable hose guide and mounting post kits are available through your Bobcat dealer.

Figure 46

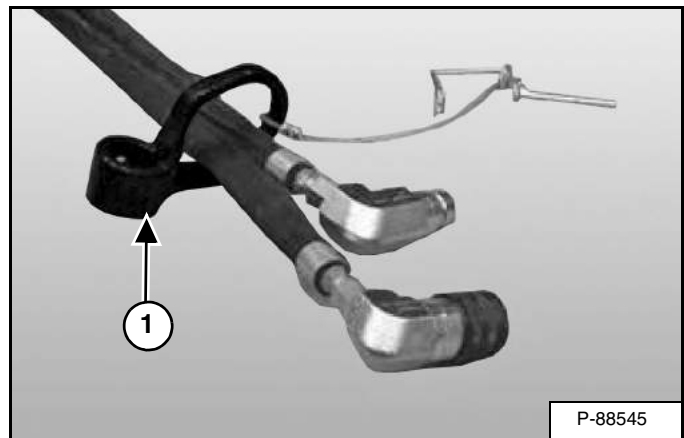

The removable hose guide (Item 1) [Figure 46] is pre-installed on the hydraulic hoses. If the orientation of the hose guide needs to be changed. (See Hose Guide Installation (Removable - If Equipped) on Page 32.)

OPERATING PROCEDURE WITH LOADERS (CONT'D)

Installation (Cont'd)

Hose Routing (Removable - If Equipped) (Cont'd)

Figure 47

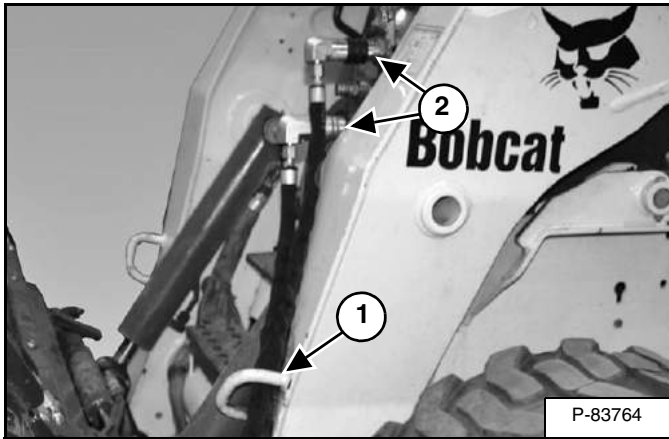

If your loader has an earlier version hose guide, route the attachment hydraulic hoses through the hose guide (Item 1). Connect the quick couplers to the loader (Item 2) [Figure 47]. (See Hydraulic Quick Couplers on Page 43.)

Figure 48

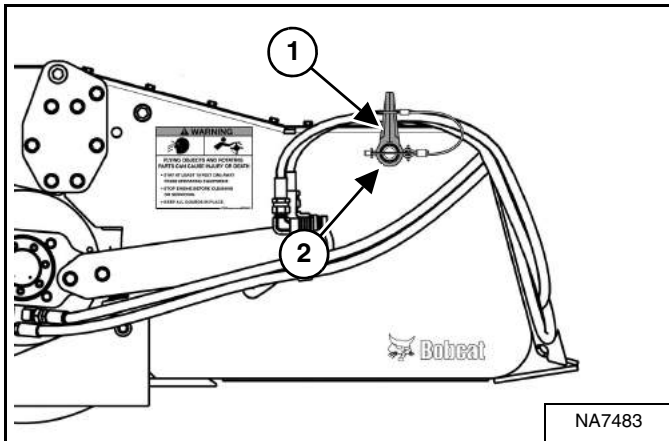

Remove the removable hose guide (Item 1) from the storage post (Item 2) [Figure 48] (if equipped).

Figure 49

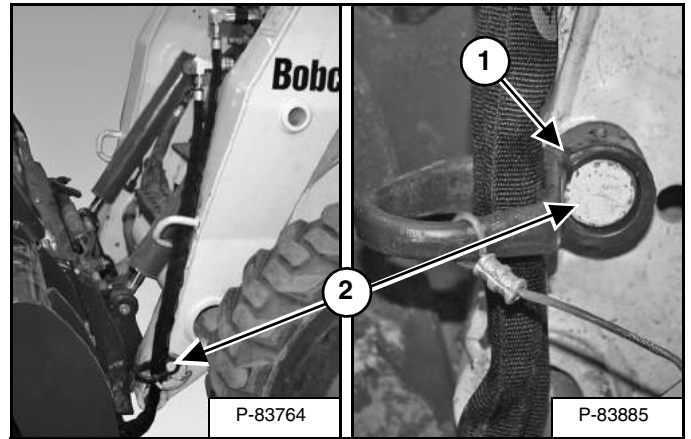

Install the removable hose guide (Item 1) onto the mounting post (Item 2) [Figure 49] located on the side of the loader lift arm.

Figure 50

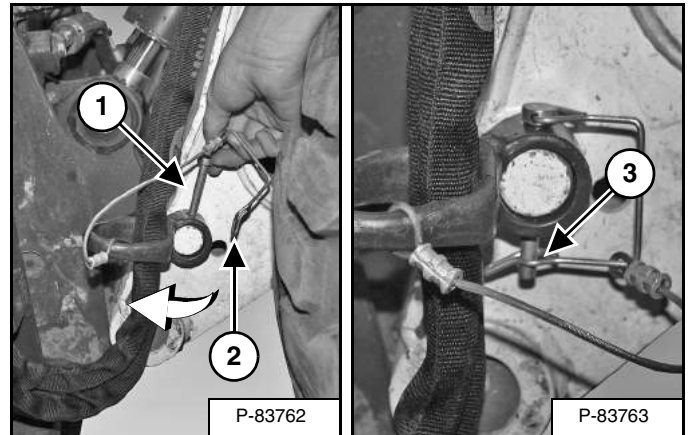

Insert lock pin (Item 1) through the removable hose guide and mounting post and latch eyelet (Item 2) onto the lock pin (Item 3) [Figure 50].

OPERATING PROCEDURE WITH LOADERS (CONT'D)

Installation (Cont'd)

For First Time Installation

New attachments and new loaders are factory equipped with flush face couplers. If installing an attachment equipped with poppet style couplers, the attachment couplers will have to be changed to match the loader. See your Bobcat dealer for parts information.

IMPORTANT

- **Thoroughly clean the quick couplers before making connections. Dirt can quickly damage the system.**
- **Contain and dispose of any oil leakage in an environmentally safe manner.**

I-2278-0608

With the loader engine off and using the hose guides (if equipped), route the attachment hydraulic hoses to the loader. Connect the attachment hydraulic quick couplers to the loader couplers. (See Hydraulic Quick Couplers on Page 43.)

Check that the attachment hydraulic hoses are not twisted or contacting any moving parts of the loader or attachment.

NOTE: It may be necessary to loosen the quick couplers on the attachment hydraulic hoses to remove any twists in the hoses.

WARNING

AVOID INJURY OR DEATH

Wear safety glasses to prevent eye injury when any of the following conditions exist:

- **When fluids are under pressure.**
- **Flying debris or loose material is present.**
- **Engine is running.**
- **Tools are being used.**

W-2019-0907

Loosen the quick coupler connections on the attachment hydraulic hoses while connected to the loader. Do not remove the quick couplers.

Rotate the attachment hydraulic hoses as needed so the hoses are not twisted or contacting any moving parts of the loader or attachment.

With the twist(s) removed from the hydraulic hoses, tighten the attachment quick coupler connections while the couplers are still connected to the loader. This will help hold the hydraulic hoses in position while tightening.

Tighten the quick couplers connections to 63 N•m (46 ft-lb) torque before starting the loader.

Enter the loader. (See Entering And Exiting The Loader on Page 34.)

Start the engine, press the PRESS TO OPERATE LOADER button and release the parking brake.

Engage auxiliary hydraulics. (See the loader's Operation & Maintenance Manual and Operator's Handbook for correct procedure.)

WARNING

AVOID INJURY OR DEATH

Diesel fuel or hydraulic fluid under pressure can penetrate skin or eyes, causing serious injury or death. Fluid leaks under pressure may not be visible. Use a piece of cardboard or wood to find leaks. Do not use your bare hand. Wear safety goggles. If fluid enters skin or eyes, get immediate medical attention from a physician familiar with this injury.

W-2072-0807

Check the attachment hydraulic quick coupler connections for leaks.

OPERATING PROCEDURE WITH LOADERS (CONT'D)

Hydraulic Quick Couplers

IMPORTANT

- Thoroughly clean the quick couplers before making connections. Dirt can quickly damage the system.
- Contain and dispose of any oil leakage in an environmentally safe manner.

I-2278-0608

New attachments and new loaders are factory equipped with flush face couplers. If installing an attachment equipped with poppet style couplers, the attachment couplers will have to be changed to match the loader. See your Bobcat dealer for parts information.

NOTE: Make sure the quick couplers are fully engaged. If the quick couplers do not fully engage, check to see that the couplers are the same size and type.

Figure 51

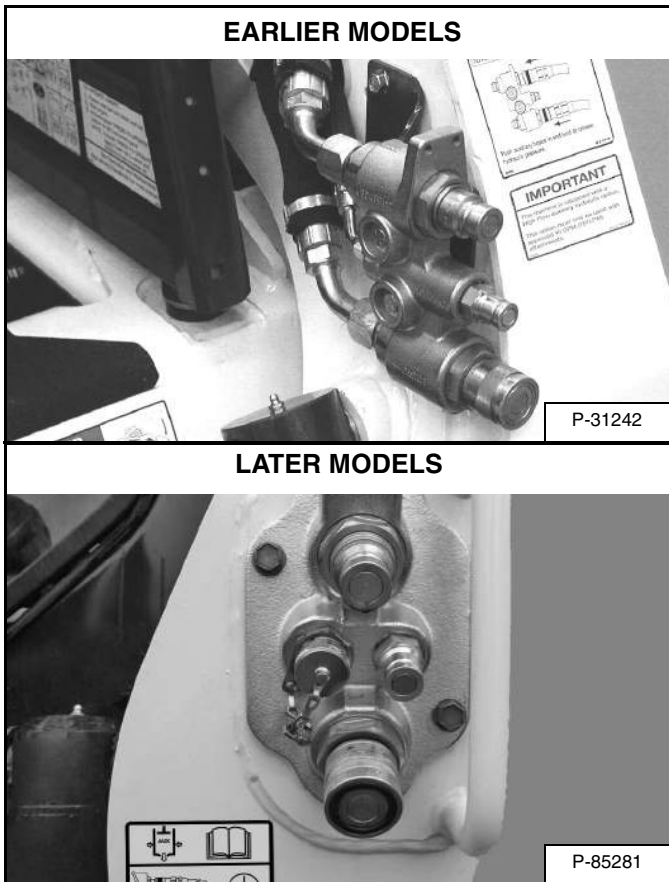

! WARNING

AVOID BURNS

Hydraulic fluid, tubes, fittings and quick couplers can get hot when running machine and attachments. Be careful when connecting and disconnecting quick couplers.

W-2220-0396

To Connect:

Remove any dirt or debris from the surface of both the male and female couplers, and from the outside diameter of the male coupler. Visually check the couplers for corroding, cracking, damage, or excessive wear. If any of these conditions exist, the coupler(s) must be replaced [Figure 51].

Install the male coupler into the female coupler. Full connection is made when the ball release sleeve slides forward on the female coupler [Figure 51].

NOTE: Check that the attachment hydraulic hoses are not twisted or contacting any moving parts of the loader or attachment. (See For First Time Installation on Page 42.) for proper adjustment.

To Disconnect:

Relieve hydraulic pressure. (See the loader's Operation & Maintenance Manual and Operator's Handbook for correct procedure.)

Push the couplers together, retract the sleeve on the female coupler until the couplers disconnect.

OPERATING PROCEDURE WITH LOADERS (CONT'D)

Hydraulic Quick Couplers (Cont'd)

Figure 52

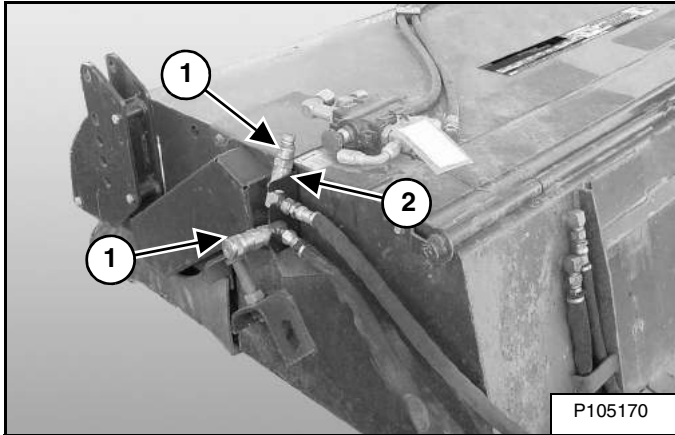

When the sweeper is not connected to the loader, install the hoses (Item 1) into the hose hanger bracket (Item 2) [Figure 52] (if equipped).

Figure 53

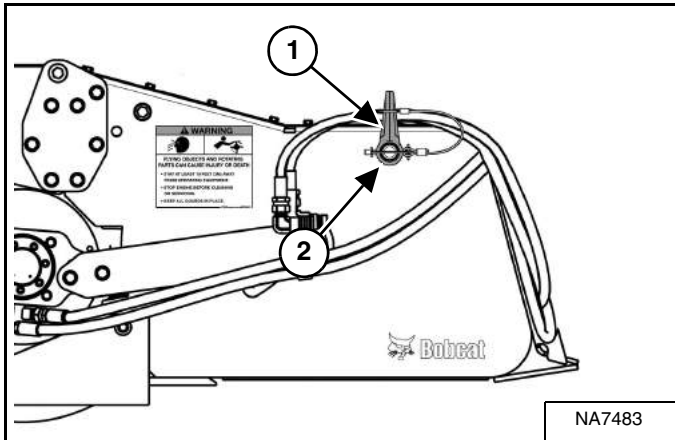

When the sweeper is not connected to the loader, install the removable hose guide (Item 1) onto the storage post (Item 2) [Figure 53] (if equipped).

Control Functions

NOTE: The auxiliary hydraulics must be activated prior to attachment operation.

NOTE: Do not operate sweeper using high flow auxiliary hydraulics.

Enter the loader. (See Entering And Exiting The Loader on Page 34.)

Start the engine and release the parking brake.

Engage auxiliary hydraulics. (See the loader's Operation & Maintenance Manual and Operator's Handbook for correct procedure.)

Figure 54

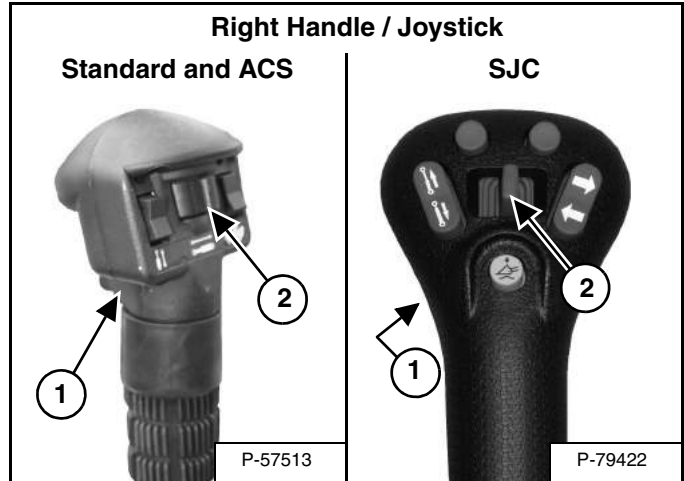

Push the front button (Item 1) [Figure 54] on the right steering lever once for continuous flow, the brush will rotate counterclockwise to sweep in a forward direction.

Push the button (Item 1) [Figure 54] a second time to disengage continuous flow (detent).

To reverse the sweeper rotation, press the switch (Item 2) [Figure 54] to the left.

Continuous (Detent) Reverse Direction Operation

To activate continuous reverse sweeper rotation, hold the switch (Item 2) to the left and press the button (Item 1) [Figure 54].

To deactivate continuous reverse operation, push the button (Item 1) [Figure 54] a second time.

OPERATING PROCEDURE WITH LOADERS (CONT'D)

Operation With The Loader

Sweeper Operation

Figure 55

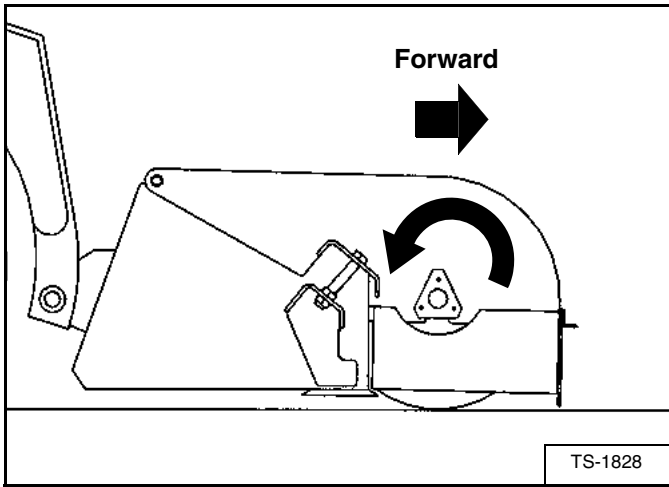

Lower the sweeper slowly to the surface. Make sure the cutting edge of the sweeper bucket is level and just above the surface and the brushes are in contact with the surface [Figure 55].

Put the loader lift arms in the float position and use the tilt function to level the sweeper. (See the loader's Operation & Maintenance Manual and Operator's Handbook for correct procedure.)

WARNING

AVOID INJURY OR DEATH

- Bystanders must keep at least 3 m (10 ft) away from the machine and attachment when operating.
- Never leave the operating position when the engine is running.

W-2320-0910

Figure 56

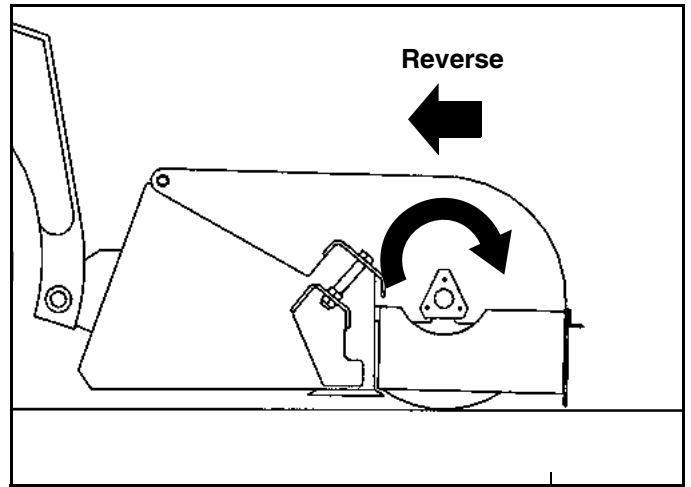

If the debris is packed (or stuck) on the surface and the broom will not sweep it up, reverse broom rotation. (See Control Functions on Page 44.) Lower the cutting edge to the surface and move the loader backward. The attachment cutting edge will scrape the surface while the broom sweeps the debris into the bucket [Figure 56].

WARNING

AVOID INJURY OR DEATH

Wear safety glasses to prevent eye injury when any of the following conditions exist:

- When fluids are under pressure.
- Flying debris or loose material is present.
- Engine is running.
- Tools are being used.

W-2019-0907

OPERATING PROCEDURE WITH LOADERS (CONT'D)

Operation With The Loader (Cont'd)

Figure 57

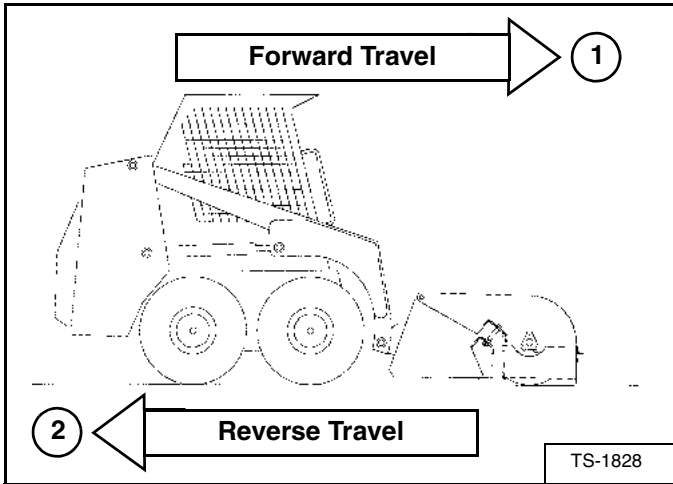
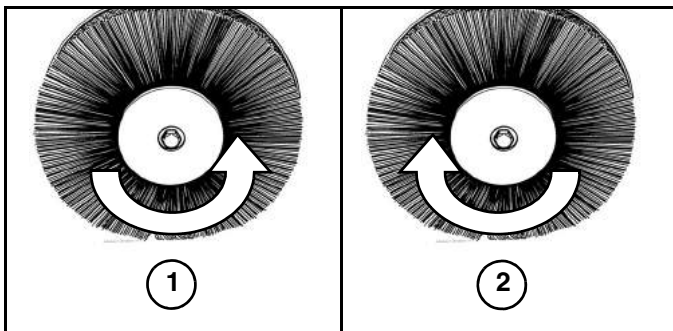

Figure 58



Forward Travel

When traveling in the forward direction (Item 1) [Figure 57] operate the sweeper in the counterclockwise direction (Item 1) [Figure 58] with the cutting edge slightly above the surface to be swept.

NOTE: Traveling in the forward direction (Item 1) [Figure 57] reduces wear on cutting edge and reduces scratching of swept surface.

Reverse Travel

When traveling in the reverse direction (Item 2) [Figure 57] operate the sweeper in the clockwise direction (Item 2) [Figure 58] with the cutting edge set on the surface to be swept.

Bristles Types

1. High Carbon Wire - For use with aggressive conditions such as mud, rocks, etc.
2. Polypropylene - For use with normal conditions such as dirt, sand, leaves, etc.
3. Combination Of Bristles - For use with varying conditions such as dry sweeping. (Not as effective for aggressive conditions.)

Figure 59

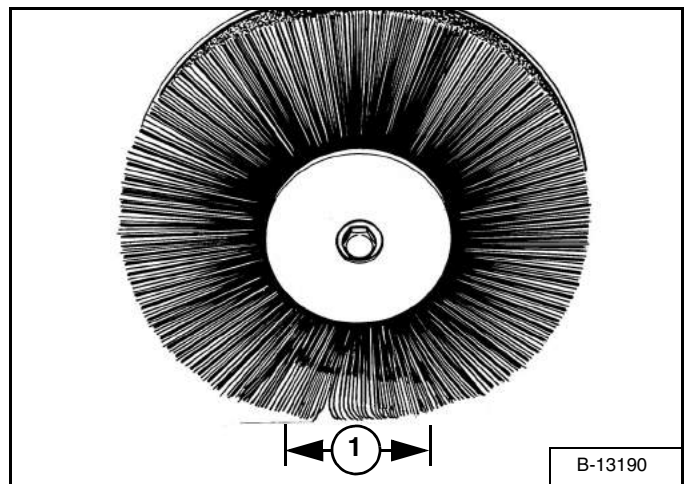

A 50 - 76 mm (2 - 3 in) (Item 1) [Figure 59] pattern is recommended for ground contact and allows the tips, or ends of the bristles, to dig and break up the debris then throw the debris off the swept surface into the bucket.

Excessive down pressure can result in the following problems which will reduce broom performance:

1. The sides of the bristles trying to dig and break up the debris and cause increased wear at the contact point.
2. The bristles are stressed and can break off in full length pieces.

OPERATING PROCEDURE WITH LOADERS (CONT'D)

Operation With The Loader (Cont'd)

Dumping The Sweeper

WARNING

AVOID INJURY OR DEATH

LIFT RESTRICTION - While dumping a loaded sweeper, the lowest part of the sweeper should not exceed 0,3 m (1 ft) from the ground. Tipping can result.

Lower sweeper to ground and stop engine before cleaning, servicing or repairing.

Consult the LIFT RESTRICTION decal before lifting or dumping.

W-2525-0910

NOTE: (See ATTACHMENT SIGNS (DECALS) on Page 18.) for location of lift restriction decal.

Figure 60



Lift the attachment off the ground. Tilt the sweeper attachment forward until it is empty [Figure 60]. The broom can be rotated to help empty the attachment. See Lift Restriction decal, before lifting or dumping.

OPERATING PROCEDURE WITH LOADERS (CONT'D)

Operation With The Loader (Cont'd)

Gutter Brush Operation (If Equipped)

Figure 61

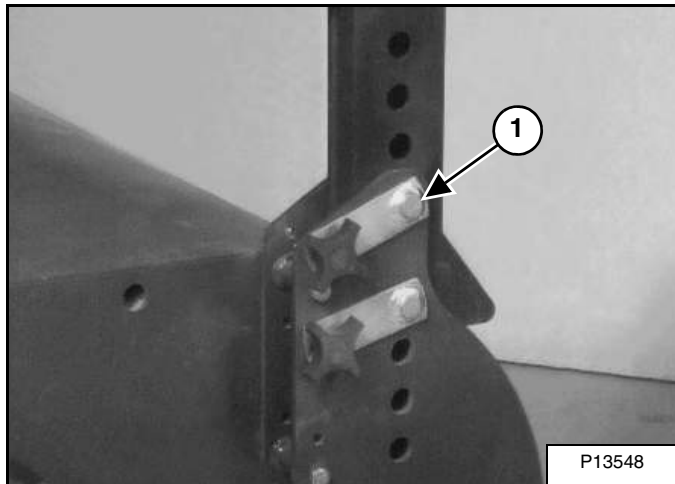
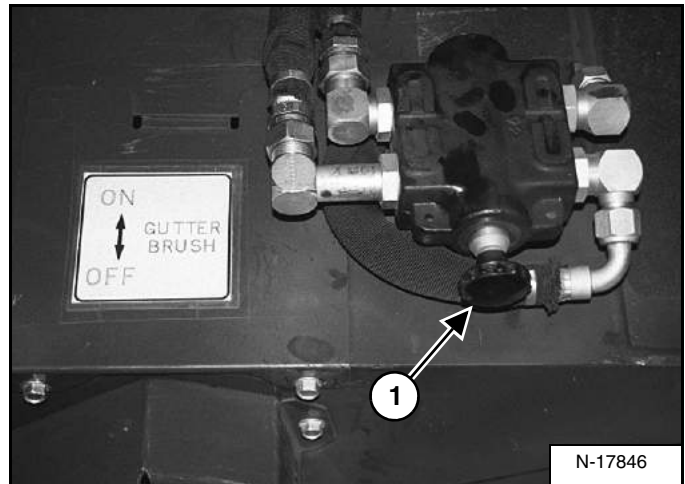

Figure 62



Remove the transport pin (Item 1) [Figure 61] and lower the gutter brush to the sweeping position [Figure 62].

Figure 63



Push the knob (Item 1) [Figure 63] into the ON position. The gutter brush will start to turn with the sweeper brush when the auxiliary hydraulics is engaged.

Figure 64

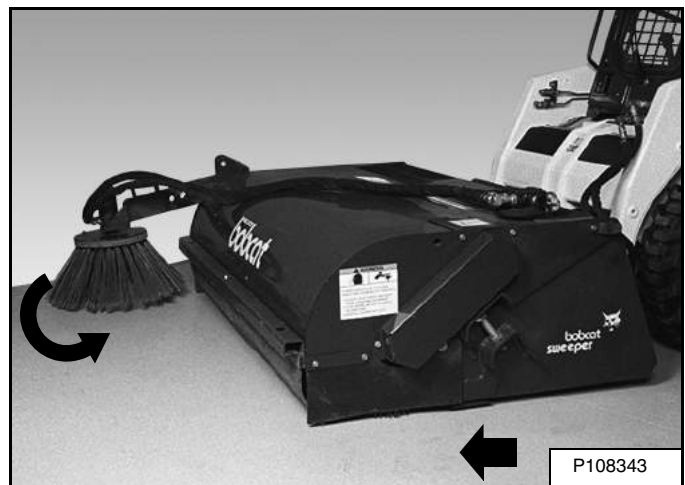

The gutter brush is designed to sweep debris from a curb or gutter out in front of the sweeper with the sweeper in a forward travel direction [Figure 64].

If the bucket sweeper is used in the reverse mode (scraping / sweeping) for any length of time, the gutter brush should be switched OFF and lifted to the transport position or removed from the sweeper.

The gutter brush can be mounted on either side of the sweeper. (See Gutter Brush on Page 23.)

OPERATING PROCEDURE WITH LOADERS (CONT'D)

Removal

Hose Removal (Removable - If Equipped)

Figure 65

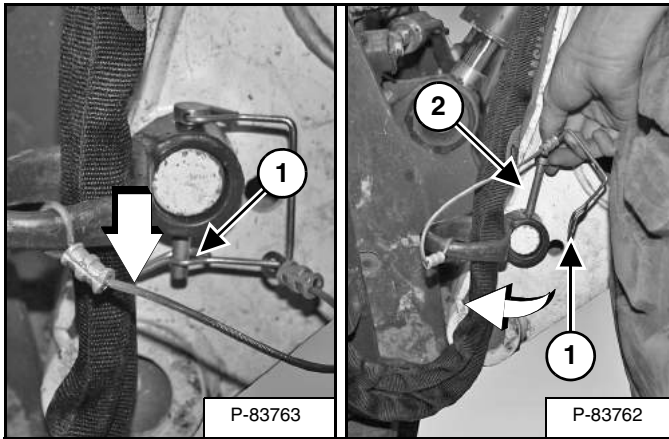

Unlatch eyelet (Item 1) from the lock pin (Item 2). Remove lock pin (Item 2) [Figure 65] from the removable hose guide and mounting post.

Figure 66

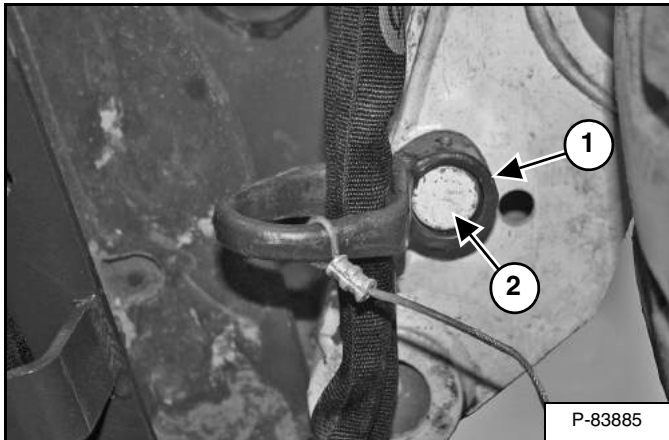

Remove the removable hose guide (Item 1) from the mounting post (Item 2) [Figure 66].

Disconnect the hydraulic quick couplers. (See Hydraulic Quick Couplers on Page 43.)

Remove hoses from hose guide (earlier version).

Figure 67

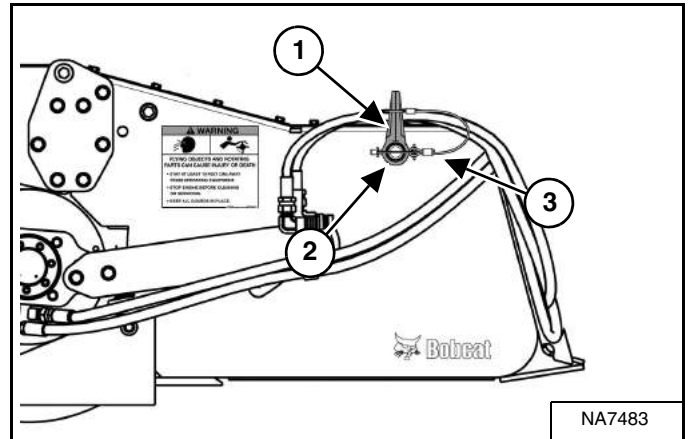

Install the removable hose guide (Item 1) onto the storage post (Item 2) [Figure 67] (if equipped).

Insert lock pin (Item 3) [Figure 67] through the removable hose guide and storage post. Latch eyelet onto the lock pin.

OPERATING PROCEDURE WITH LOADERS (CONT'D)

Removal (Cont'd)

Hand Lever Bob-Tach

Lower the lift arms and put the attachment flat on the ground. Lower or close the hydraulic equipment (if equipped).

NOTE: In muddy conditions or to prevent the attachment from freezing to the ground, put the attachment on planks or blocks before removing the attachment from the loader.

Stop the engine and release auxiliary hydraulic pressure (if applicable). (See the loader's Operation & Maintenance Manual and Operator's Handbook for correct procedure.)

Exit the loader. (See Entering And Exiting The Loader on Page 34.)

! WARNING

AVOID INJURY OR DEATH

Before you leave the operator's seat:

- Lower the lift arms and put the attachment flat on the ground.
- Stop the engine.
- Engage the parking brake.
- Raise the seat bar.
- Move all controls to the **NEUTRAL / LOCKED** position to make sure the lift, tilt and traction drive functions are deactivated.

The seat bar system must deactivate these functions when the seat bar is up. See your Bobcat dealer for service if controls do not deactivate.

W-2463-1110

Disconnect auxiliary hydraulic hoses (if applicable). (See Hydraulic Quick Couplers on Page 43.)

Figure 68

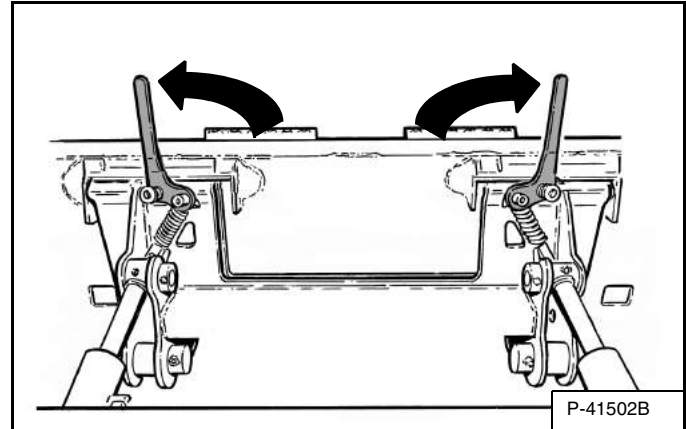

Pull the Bob-Tach levers up [Figure 68] until they are fully raised (wedges fully raised).

! WARNING

Bob-Tach levers have spring tension. Hold lever tightly and release slowly. Failure to obey warning can cause injury.

W-2054-1285

Enter the loader. (See Entering And Exiting The Loader on Page 34.)

Start the engine, press the PRESS TO OPERATE LOADER button and release the parking brake.

Figure 69

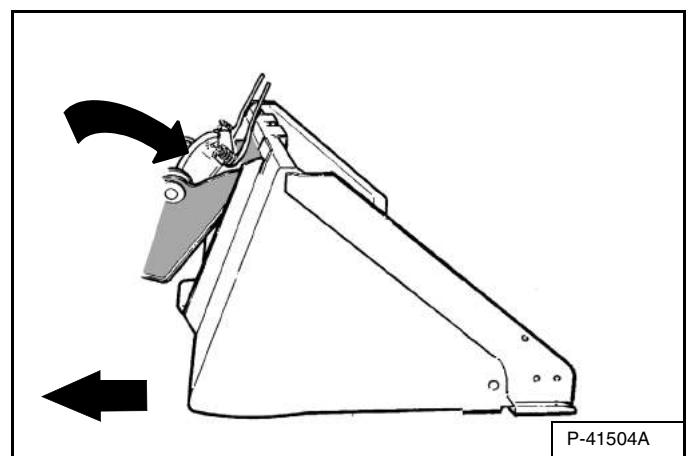

Tilt the Bob-Tach forward and drive the loader backward, away from the attachment [Figure 69].

OPERATING PROCEDURE WITH LOADERS (CONT'D)

Removal (Cont'd)

Power Bob-Tach

Lower the lift arms and put the attachment flat on the ground. Lower or close the hydraulic equipment (if equipped).

NOTE: In muddy conditions or to prevent the attachment from freezing to the ground, put the attachment on planks or blocks before removing the attachment from the loader.

Stop the engine and release auxiliary hydraulic pressure (if applicable). (See the loader's Operation & Maintenance Manual and Operator's Handbook for correct procedure.)

Exit the loader. (See Entering And Exiting The Loader on Page 34.)



AVOID INJURY OR DEATH

Before you leave the operator's seat:

- Lower the lift arms and put the attachment flat on the ground.
- Stop the engine.
- Engage the parking brake.
- Raise the seat bar.
- Move all controls to the **NEUTRAL / LOCKED** position to make sure the lift, tilt and traction drive functions are deactivated.

The seat bar system must deactivate these functions when the seat bar is up. See your Bobcat dealer for service if controls do not deactivate.

W-2463-1110

Disconnect auxiliary hydraulic hoses (if applicable). (See Hydraulic Quick Couplers on Page 43.)

Enter the loader. (See Entering And Exiting The Loader on Page 34.)

Start the engine, press the PRESS TO OPERATE LOADER button and release the parking brake.

Figure 70

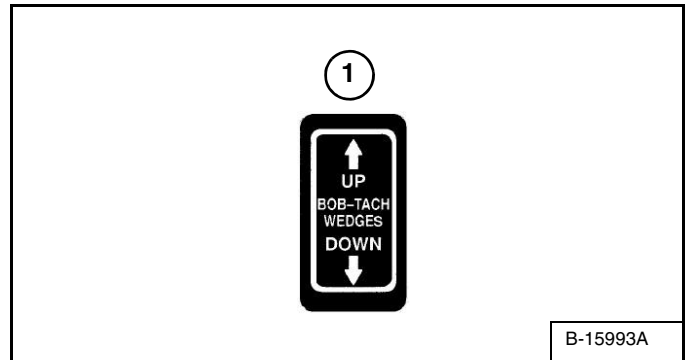
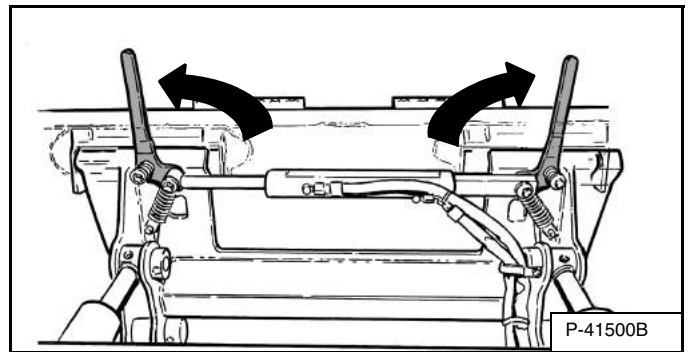

Figure 71



Push and hold the BOB-TACH "WEDGES UP" switch (Item 1) [Figure 70] (Front Panel) until the levers [Figure 71] are fully raised (wedges fully raised).

OPERATING PROCEDURE WITH LOADERS (CONT'D)

Removal (Cont'd)

Power Bob-Tach (Cont'd)

Figure 72

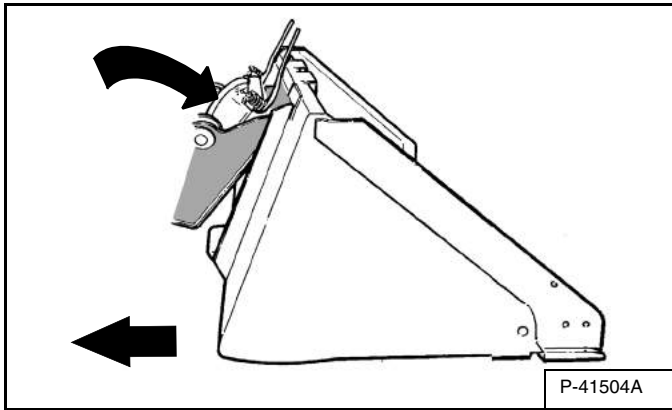

Tilt the Bob-Tach forward and drive the loader backward, away from the attachment [Figure 72].

NOTE: The Power Bob-Tach system has continuous pressurized hydraulic oil to keep the wedges in the engaged position and prevent attachment disengagement. Because the wedges can slowly lower, the operator may need to reactivate the switch (BOB-TACH “WEDGES UP”) when removing an attachment to be sure both wedges are fully raised.

OPERATING PROCEDURE WITH VERSAHANDLERS

Approved VersaHANDLER Models And Requirements

Figure 73

VERSAHANDLER MODEL	54 SWEEPER	60 SWEEPER	72 SWEEPER
V518			X
V723			X

X = Approved

The chart [Figure 73] shows the approved sweeper models for each VersaHANDLER® model.

The warranty is void if this attachment is used on a non-approved carrier. See your Bobcat dealer for an updated list of approved carriers.



WARNING

Never use attachments or buckets which are not approved by the Bobcat Company. Attachments and buckets for safe loads of specified densities are approved for each model. Unapproved attachments and buckets can cause injury or death.

W-2662-0108

Figure 74



The VersaHANDLER must be equipped with front auxiliary hydraulics [Figure 74] for proper operation of the sweeper. See your Bobcat dealer for available kits.

Figure 75

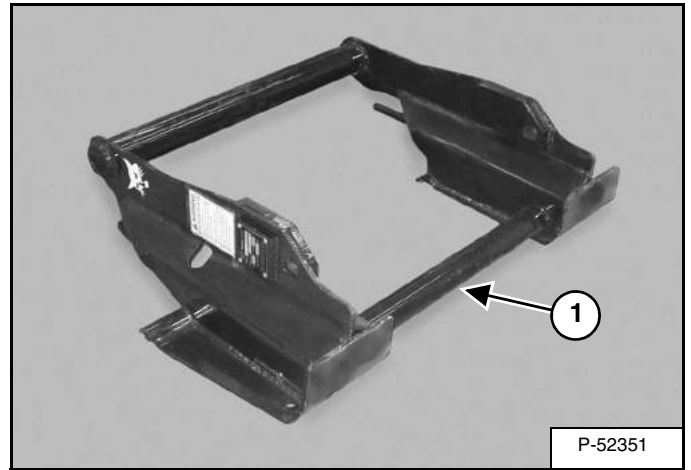

The adapter frame (Item 1) [Figure 75] is required to properly mount the sweeper to the VersaHANDLER.

OPERATING PROCEDURE WITH VERSAHANDLERS (CONT'D)

Machine / Attachment Setup

Hose Guide Installation (Sweeper)

Figure 76

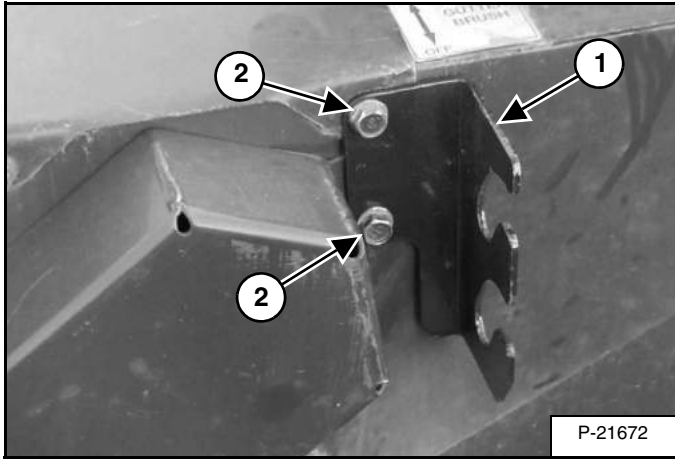

On some sweepers, the hose hanger bracket (Item 1) is not installed. The bracket will then be included in the shipping bag. Remove the two existing bolts (Item 2) and install the hose hanger bracket (Item 1) [Figure 76].

Figure 77

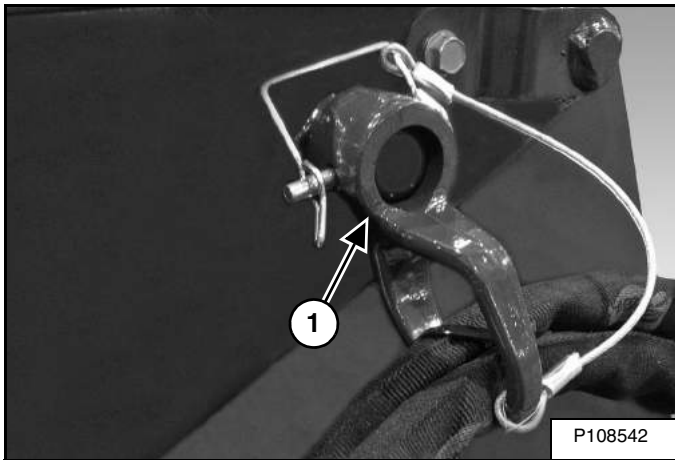

On some sweepers, the removable hose guide (Item 1) [Figure 77] is located on the left side of the sweeper.

OPERATING PROCEDURE WITH VERSAHANDLERS (CONT'D)

Entering And Exiting The VersaHANDLER

Entering



AVOID INJURY OR DEATH

When operating the machine:

- Keep the seat belt fastened snugly.
- Lower the restraint bar (if equipped).
- Keep your feet and arms inside the cab.

W-2810-1109

Figure 78

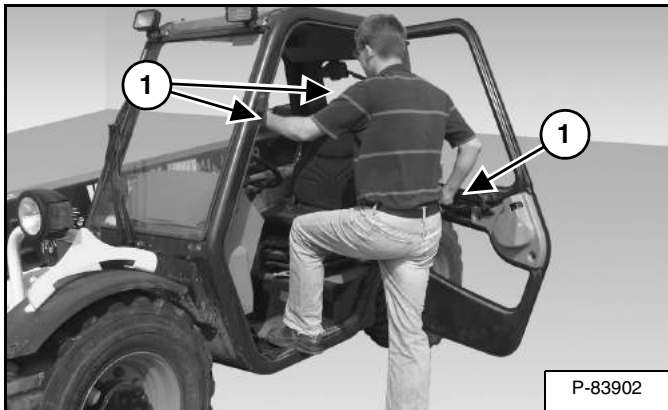

Use the hand grabs (Item 1) [Figure 78] to enter the operator cab.

NOTE: Maintain three-point contact at all times while entering or exiting the VersaHANDLER. Do not jump.

Figure 79

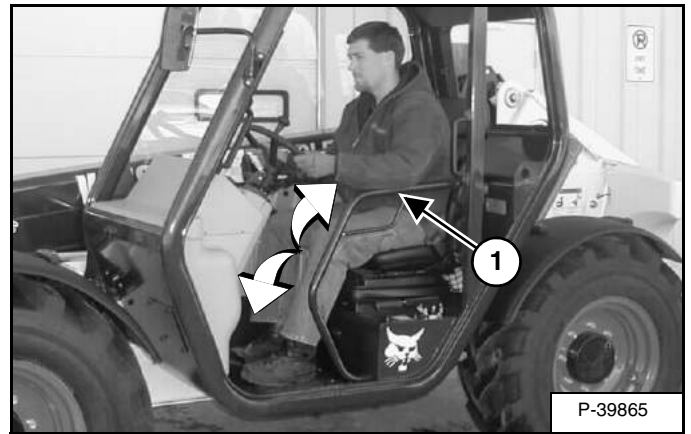

Fasten seat belt and lower the restraint bar (Item 1) [Figure 79] (if equipped), and engage the parking brake.

Put the Travel Direction Control lever and joystick in NEUTRAL.

See the VersaHANDLER's Operation & Maintenance Manual and Operator's Handbook for detailed information on operating the VersaHANDLER.

Exiting

Put the Travel Direction Control Lever and the Joystick in NEUTRAL.

Engage the parking brake.

Retract and lower the boom and attachment flat on the ground.

Stop the engine.

Raise the restraint bar (if equipped) and make sure the lift, tilt, boom extend, auxiliary hydraulic and traction drive functions are deactivated.

Remove the key.

Exit the VersaHANDLER.



Before you leave the operator's position:

- Put the travel Direction Control Lever and the Joystick in neutral.
- Engage the parking brake.
- Retract and lower the boom and attachment flat on the ground.
- Stop the engine. Raise the restraint bar (if equipped).

SEE THE MACHINE OPERATION & MAINTENANCE MANUAL FOR MORE INFORMATION.

W-2637-0607

OPERATING PROCEDURE WITH VERSAHANDLERS (CONT'D)

Installation

Hand Lever Bob-Tach

NOTE: The illustrations and instructions provided explain how to install a bucket attachment on to a VersaHANDLER. Follow these same instructions if you are installing different attachments such as a grapple, tiller, combo bucket, etc.

The attachment mounting frame for the attachment has a top flange that is designed to receive the top edge of the Bob-Tach and the lower part of the frame is designed to receive the Bob-Tach wedges.

WARNING

The signal word **WARNING** on the machine and in the manuals indicates a potentially hazardous situation which, if not avoided, could result in death or serious injury.

W-2044-1107

Always inspect the VersaHANDLER's Bob-Tach, attachment mounting frame and the adapter frame before installation. See the VersaHANDLER's Operation & Maintenance Manual. (See DAILY INSPECTION on Page 24.)

Figure 80

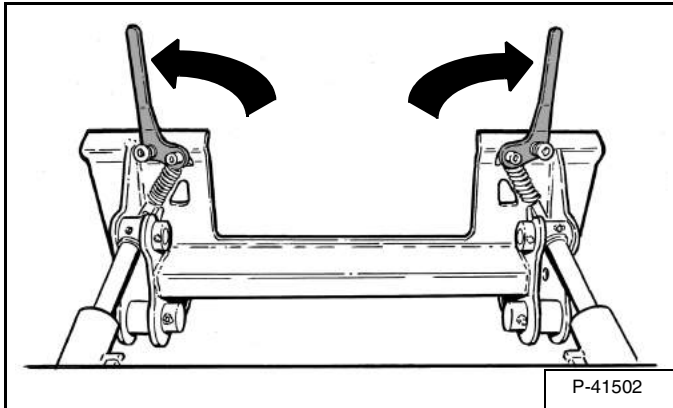

Pull the Bob-Tach levers up until they are fully raised (wedges fully raised) [Figure 80].

Enter the VersaHANDLER. (See Entering And Exiting The VersaHANDLER on Page 55.)

Start the engine and release the parking brake.

Figure 81

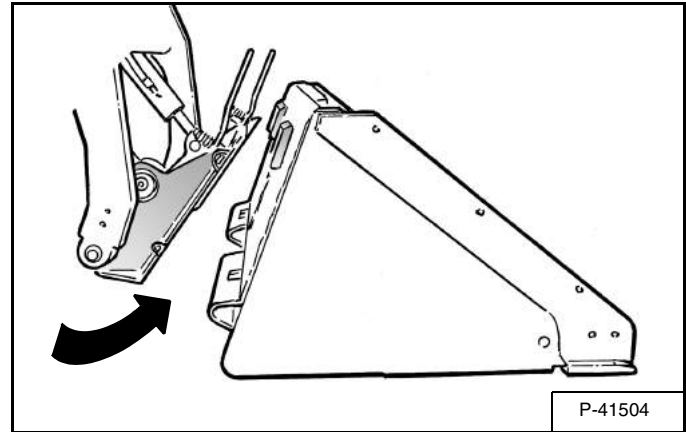

Lower the boom and tilt the Bob-Tach forward.

Drive the VersaHANDLER slowly forward until the top edge of the Bob-Tach is completely under the top flange of the attachment mounting frame [Figure 81].

NOTE: Be sure the Bob-Tach levers do not hit the attachment.

Figure 82

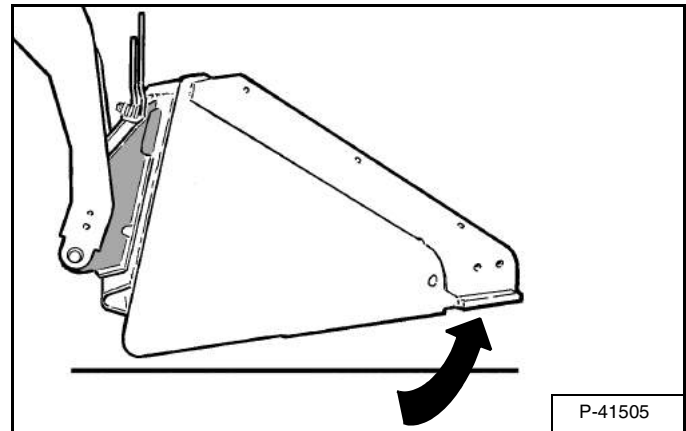

Tilt the Bob-Tach backward until the attachment is slightly off the ground [Figure 82]. This will cause the attachment mounting frame to fit up against the front of the Bob-Tach.

NOTE: When leaving the operator's seat to install an attachment, tilt the attachment until it is slightly off the ground.

Stop the engine and exit the VersaHANDLER. (See Entering And Exiting The VersaHANDLER on Page 55.)

OPERATING PROCEDURE WITH VERSAHANDLERS (CONT'D)

Installation (Cont'd)

Hand Lever Bob-Tach (Cont'd)

! WARNING

Before you leave the operator's position:

- Put the travel Direction Control Lever and the Joystick in neutral.
- Engage the parking brake.
- Retract and lower the boom and attachment flat on the ground.
- Stop the engine. Raise the restraint bar (if equipped).

SEE THE MACHINE OPERATION & MAINTENANCE MANUAL FOR MORE INFORMATION.

W-2637-0607

Figure 83

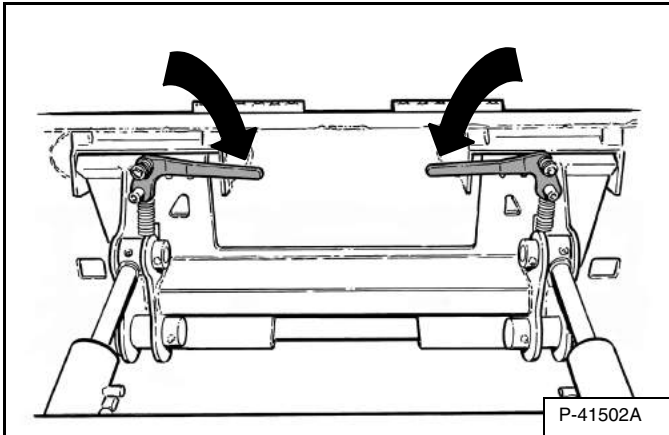

Push down on the Bob-Tach levers until they are fully engaged in the locked position [Figure 83] (wedges fully extended through the attachment mounting frame holes).

Figure 84

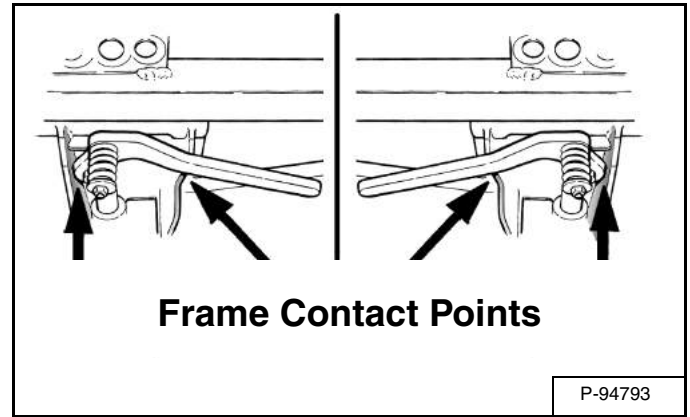

Both levers must contact the frame as shown when locked [Figure 84].

If both levers do not engage in the locked position, see your Bobcat dealer for maintenance.

! WARNING

AVOID INJURY OR DEATH

The Bob-Tach wedges must extend through the holes in the attachment mounting frame. Levers must be fully down and locked. Failure to secure wedges can allow attachment to come off.

W-2715-0208

Figure 85

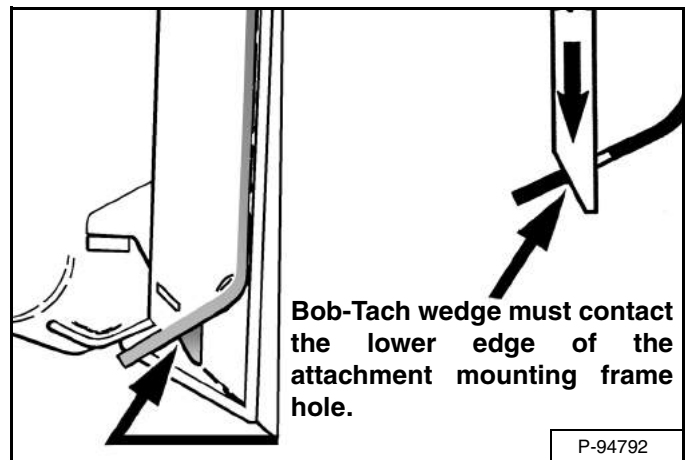

The wedges must extend through the holes in the attachment mounting frame, securely fastening the attachment to the Bob-Tach [Figure 85].

OPERATING PROCEDURE WITH VERSAHANDLERS (CONT'D)

Installation (Cont'd)

Hose Routing

Figure 86

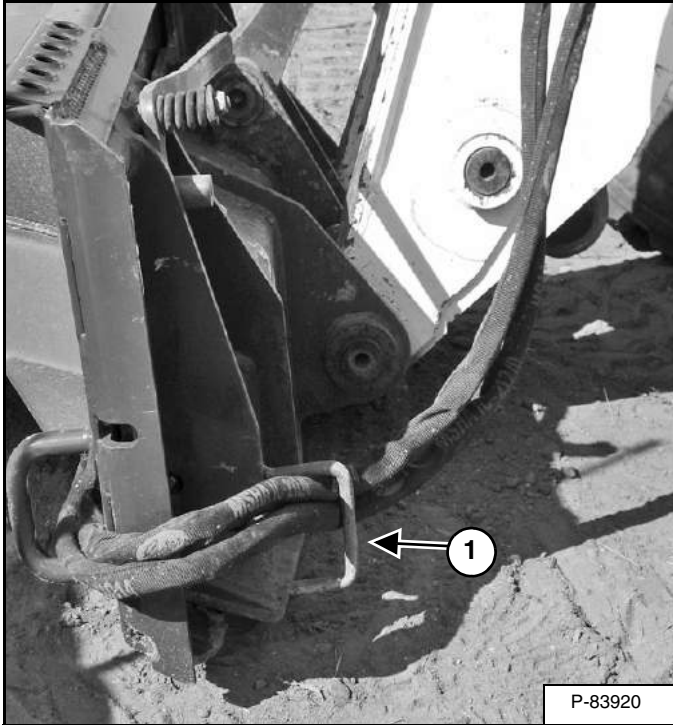

Route the hydraulic hoses through the hose guide (Item 1) [Figure 86] and connect quick couplers to the VersaHANDLER. (See Hydraulic Quick Couplers on Page 60.)

OPERATING PROCEDURE WITH VERSAHANDLERS (CONT'D)

Installation (Cont'd)

For First Time Installation

New attachments and new VersaHANDLERS are factory equipped with flush face couplers. If installing an attachment equipped with poppet style couplers, the attachment couplers will have to be changed to match the VersaHANDLER. See your Bobcat dealer for parts information.

IMPORTANT

- **Thoroughly clean the quick couplers before making connections. Dirt can quickly damage the system.**
- **Contain and dispose of any oil leakage in an environmentally safe manner.**

I-2278-0608

With the VersaHANDLER engine off and using the hose guides (if equipped), route the attachment hydraulic hoses to the VersaHANDLER. Connect the attachment hydraulic quick couplers to the VersaHANDLER couplers. (See Hydraulic Quick Couplers on Page 60.)

Check that the attachment hydraulic hoses are not twisted or contacting any moving parts of the VersaHANDLER or attachment.

NOTE: It may be necessary to loosen the quick couplers on the attachment hydraulic hoses to remove any twists in the hoses.

WARNING

AVOID INJURY OR DEATH

Wear safety glasses to prevent eye injury when any of the following conditions exist:

- **When fluids are under pressure.**
- **Flying debris or loose material is present.**
- **Engine is running.**
- **Tools are being used.**

W-2019-0907

Loosen the quick coupler connections on the attachment hydraulic hoses while connected to the VersaHANDLER. Do not remove the quick couplers.

Rotate the attachment hydraulic hoses as needed so the hoses are not twisted or contacting any moving parts of the VersaHANDLER or attachment.

With the twist(s) removed from the hydraulic hoses, tighten the attachment quick coupler connections while the couplers are still connected to the VersaHANDLER. This will help hold the hydraulic hoses in position while tightening.

Tighten the quick couplers connections to 63 N•m (46 ft•lb) torque before starting the VersaHANDLER.

Enter the VersaHANDLER. (See Entering And Exiting The VersaHANDLER on Page 55.)

Start the engine and release the parking brake.

Engage auxiliary hydraulics. (See the VersaHANDLER's Operation & Maintenance Manual and Operator's Handbook for correct procedure.)

WARNING

AVOID INJURY OR DEATH

Diesel fuel or hydraulic fluid under pressure can penetrate skin or eyes, causing serious injury or death. Fluid leaks under pressure may not be visible. Use a piece of cardboard or wood to find leaks. Do not use your bare hand. Wear safety goggles. If fluid enters skin or eyes, get immediate medical attention from a physician familiar with this injury.

W-2072-0807

Check the attachment hydraulic quick coupler connections for leaks.

OPERATING PROCEDURE WITH VERSAHANDLERS (CONT'D)

Hydraulic Quick Couplers

IMPORTANT

- Thoroughly clean the quick couplers before making connections. Dirt can quickly damage the system.
- Contain and dispose of any oil leakage in an environmentally safe manner.

I-2278-0608

New attachments and new VersaHANDLERS are factory equipped with flush face couplers. If installing an attachment equipped with poppet style couplers, the attachment couplers will have to be changed to match the VersaHANDLER. See your Bobcat dealer for parts information.

NOTE: Make sure the quick couplers are fully engaged. If the quick couplers do not fully engage, check to see that the couplers are the same size and type.

Figure 87



! WARNING

AVOID BURNS

Hydraulic fluid, tubes, fittings and quick couplers can get hot when running machine and attachments. Be careful when connecting and disconnecting quick couplers.

W-2220-0396

To Connect:

Remove any dirt or debris from the surface of both the male and female couplers, and from the outside diameter of the male coupler. Visually check the couplers for corroding, cracking, damage, or excessive wear. If any of these conditions exist, the coupler(s) must be replaced [Figure 87].

Install the male coupler into the female coupler. Full connection is made when the ball release sleeve slides forward on the female coupler [Figure 87].

NOTE: Check that the attachment hydraulic hoses are not twisted or contacting any moving parts of the VersaHANDLER or attachment. (See For First Time Installation on Page 59.) for proper adjustment.

To Disconnect:

Relieve hydraulic pressure. (See the VersaHANDLER's Operation & Maintenance Manual and Operator's Handbook for correct procedure.)

Push the couplers together, retract the sleeve on the female coupler until the couplers disconnect.

OPERATING PROCEDURE WITH VERSAHANDLERS (CONT'D)

Hydraulic Quick Couplers (Cont'd)

Figure 88

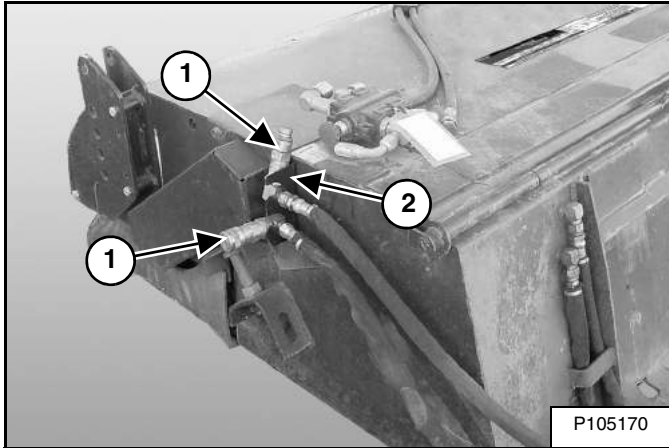

When the sweeper is not connected to the VersaHANDLER, install the hoses (Item 1) into the hose hanger bracket (Item 2) [Figure 88].

Figure 89

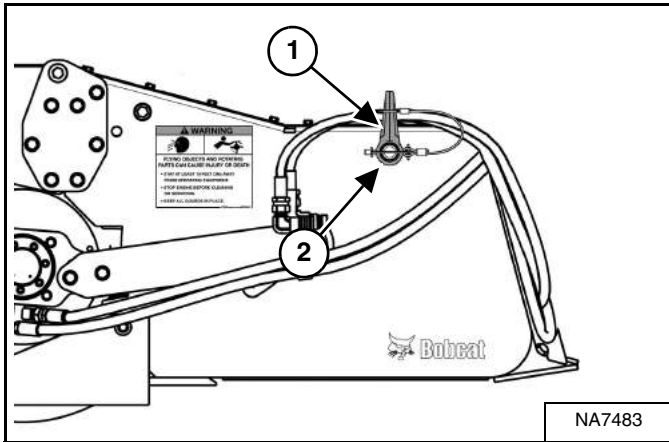

When the sweeper is not connected to the VersaHANDLER, install the removable hose guide (Item 1) onto the storage post (Item 2) [Figure 89] (if equipped).

Control Functions

IMPORTANT

When using ground engaging attachments, boom extension must not exceed 250 mm (9.8 in). Exceeding this limit can cause boom and / or hydraulic cylinder damage.

I-2266-0910

Move to the operator position, fasten seat belt and lower the restraint bar (if equipped), start the engine and disengage the parking brake. (See Entering And Exiting The VersaHANDLER on Page 55.)

Engage the auxiliary hydraulics. (See the VersaHANDLER's Operation & Maintenance Manual and Operator's Handbook for correct procedure.)

NOTE: Auxiliary hydraulics must be activated prior to attachment operation.

NOTE: Do not operate sweeper using high-flow auxiliary hydraulics.

Figure 90

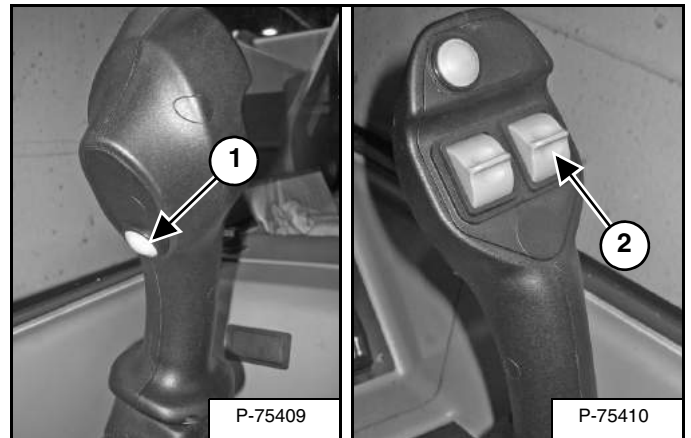

Press the button (Item 1) [Figure 90] to start the sweeper rotation. Press the button a second time to stop the sweeper.

To reverse the sweeper rotation, push and hold the switch (Item 2) down, then press the button (Item 1) [Figure 90]. Release both the switch and button for continuous sweeper rotation.

Press the button (Item 1) [Figure 90] a second time to stop the sweeper rotation.

OPERATING PROCEDURE WITH VERSAHANDLERS (CONT'D)

Operation With The VersaHANDLER

Load Capacity Chart

Figure 91

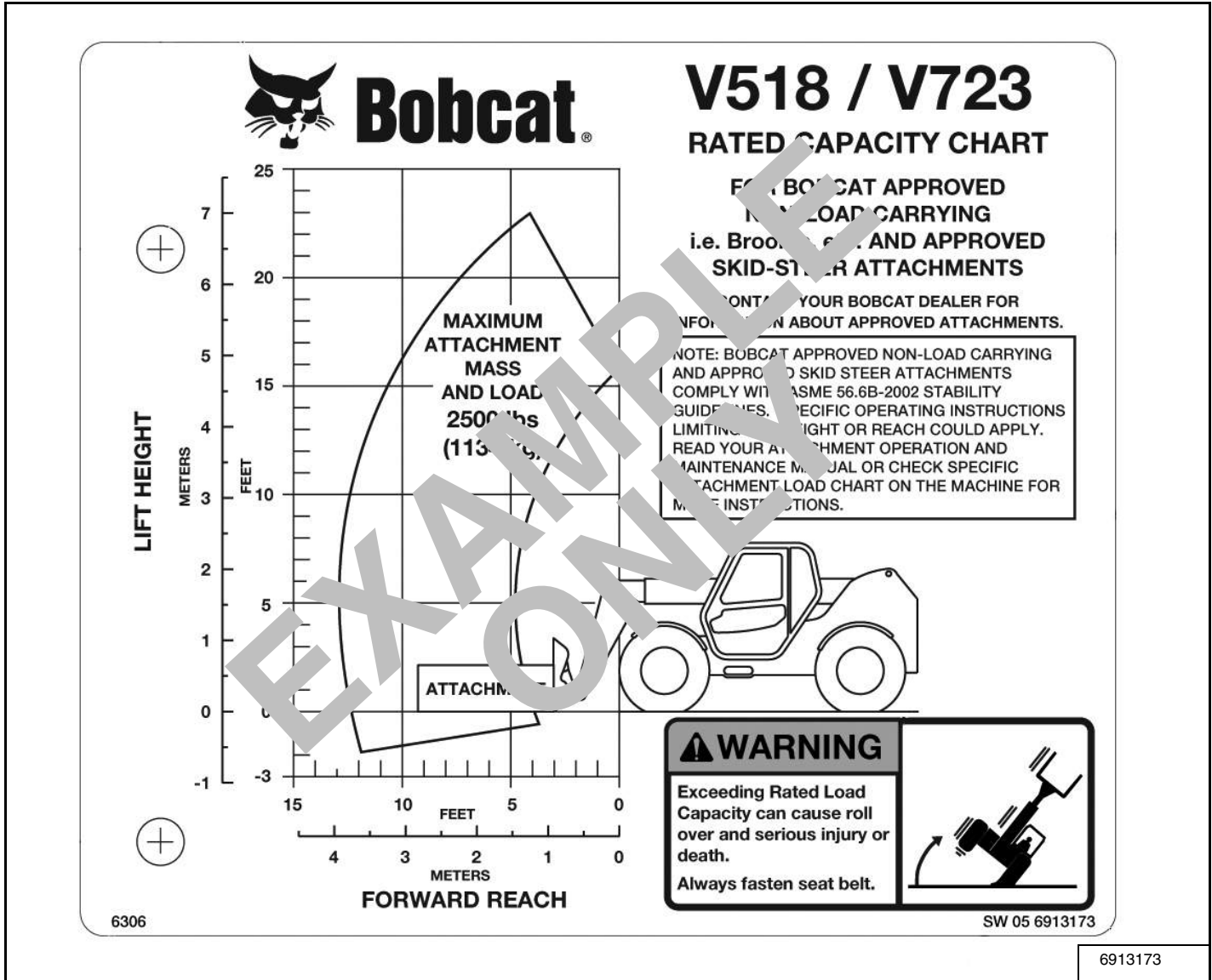

The Load Capacity Chart [Figure 91] is an “EXAMPLE ONLY”. See the VersaHANDLER Operation & Maintenance Manual and Operator’s Handbook for more information on the Load Capacity Charts for your VersaHANDLER.

OPERATING PROCEDURE WITH VERSAHANDLERS (CONT'D)

Operation With The VersaHANDLER (Cont'd)

Sweeper Operation

Figure 92

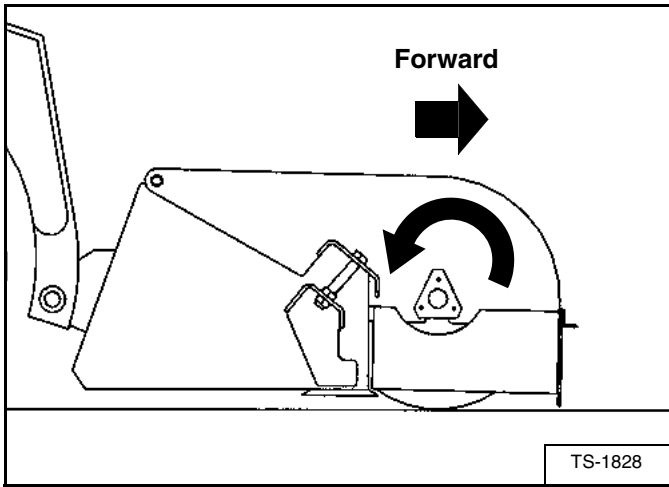

Lower the sweeper slowly to the surface. Make sure the cutting edge of the sweeper bucket is just above the surface, level with the surface and the brushes are in contact with the surface [Figure 92].

Put the VersaHANDLER boom in the float position and use the tilt function to level the sweeper. (See the VersaHANDLER's Operation & Maintenance Manual and Operator's Handbook for correct procedure.)

WARNING

AVOID INJURY OR DEATH

- Bystanders must keep at least 3 m (10 ft) away from the machine and attachment when operating.
- Never leave the operating position when the engine is running.

W-2320-0910

Figure 93

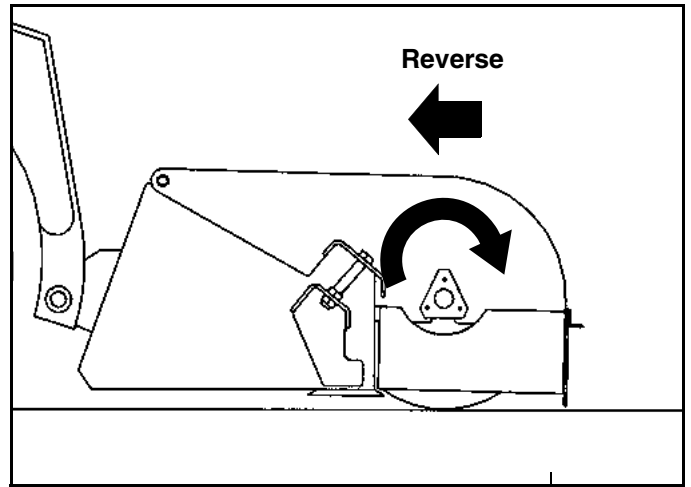

If the debris is packed (or stuck) on the surface and the broom will not sweep it up, reverse broom rotation. (See Control Functions on Page 61.) Lower the cutting edge to the surface and move the VersaHANDLER backward. The attachment cutting edge will scrape the surface while the broom sweeps the debris into the bucket [Figure 93].

WARNING

AVOID INJURY OR DEATH

Wear safety glasses to prevent eye injury when any of the following conditions exist:

- When fluids are under pressure.
- Flying debris or loose material is present.
- Engine is running.
- Tools are being used.

W-2019-0907

OPERATING PROCEDURE WITH VERSAHANDLERS (CONT'D)

Operation With The VersaHANDLER (Cont'd)

Sweeper Operation (Cont'd)

Figure 94

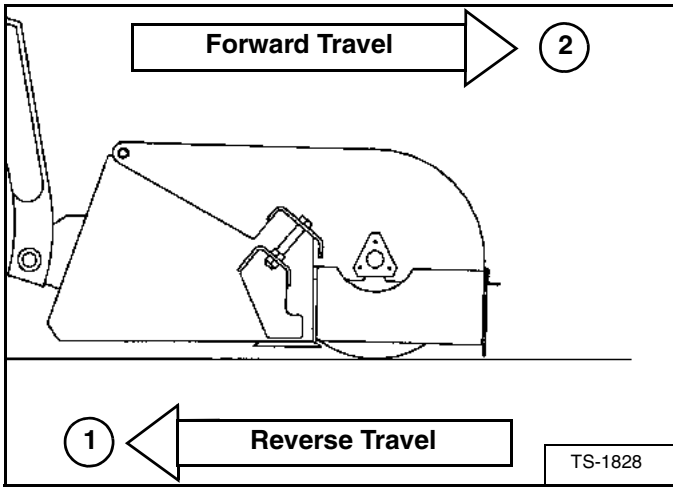
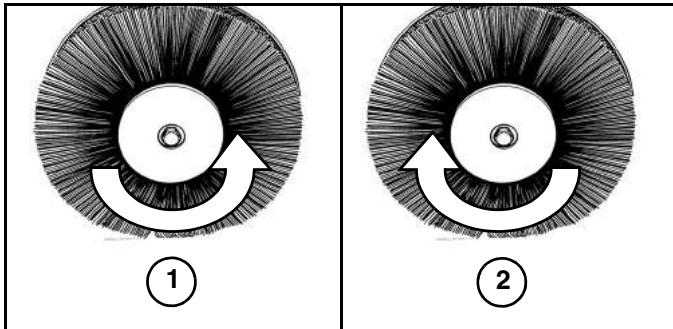

Figure 95



Forward Travel

When traveling in the forward direction (Item 1) [Figure 94] operate the sweeper in the counterclockwise direction (Item 1) [Figure 95] with the cutting edge slightly above the surface to be swept.

NOTE: Traveling in the forward direction (Item 1) [Figure 94] reduces wear on cutting edge and reduces scratching of swept surface.

Reverse Travel

When traveling in the reverse direction (Item 2) [Figure 94] operate the sweeper in the clockwise direction (Item 2) [Figure 95] with the cutting edge set on the surface to be swept.

Bristles Types

1. High Carbon Wire - For use with aggressive conditions such as mud, rocks, etc.
2. Polypropylene - For use with normal conditions such as dirt, sand, leaves, etc.
3. Combination Of Bristles - For use with varying conditions such as dry sweeping. (Not as effective for aggressive conditions.)

Figure 96

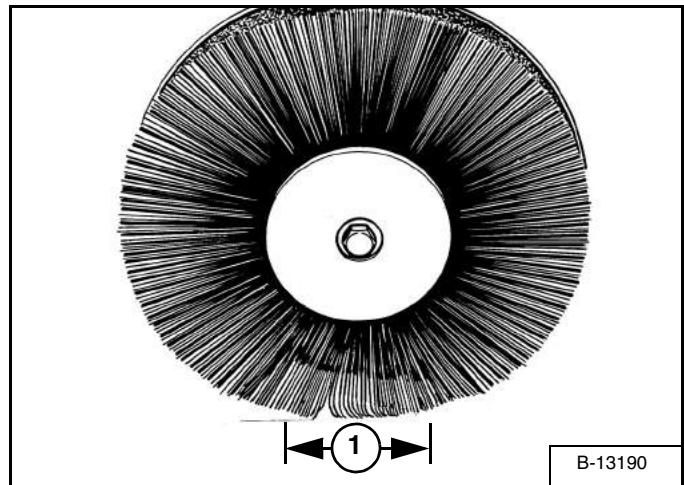

A 50 - 76 mm (2 - 3 in) (Item 1) [Figure 96] pattern is recommended for ground contact and allows the tips, or ends of the bristles, to dig and break up the debris then throw the debris off the swept surface into the bucket.

Excessive down pressure can result in the following problems which will reduce broom performance:

1. The sides of the bristles trying to dig and break up the debris and cause increased wear at the contact point.
2. The bristles are stressed and can break off in full length pieces.

OPERATING PROCEDURE WITH VERSAHANDLERS (CONT'D)

Operation With The VersaHANDLER (Cont'd)

Dumping The Sweeper

Figure 97



Lift the attachment off the ground. Tilt the sweeper attachment forward until it is empty **[Figure 97]**. The broom can be rotated to help empty the attachment.

Gutter Brush Operation (If Equipped)

Figure 98

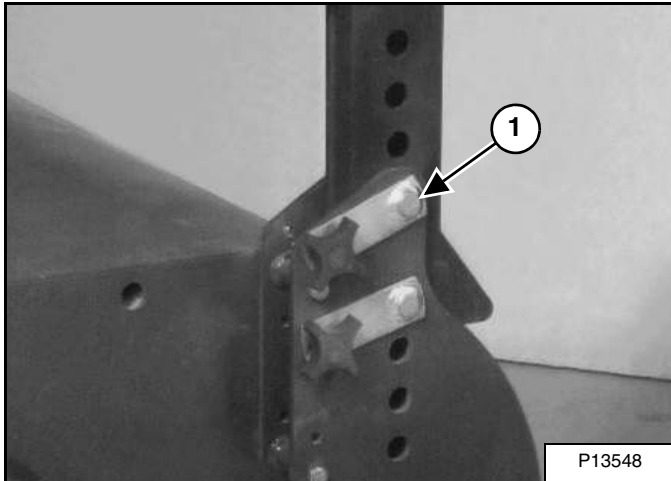
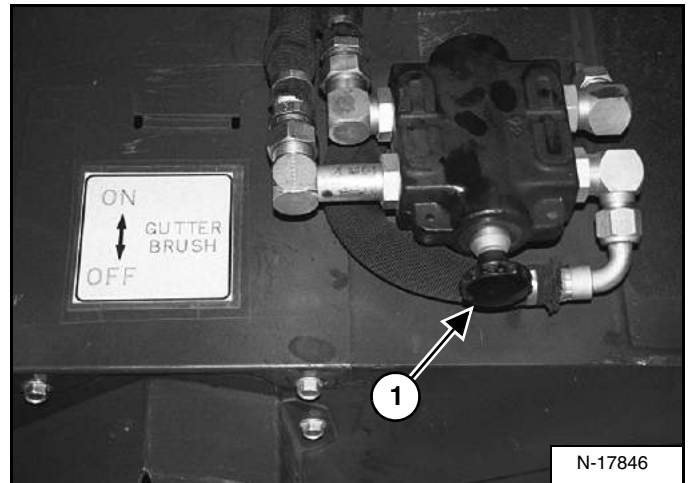

Figure 99



Remove the transport pin (Item 1) **[Figure 98]** and lower the gutter brush to the sweeping position **[Figure 99]**.

Figure 100



Push the knob (Item 1) **[Figure 100]** into the ON position. The gutter brush will start to turn with the sweeper brush when the auxiliary hydraulics is engaged.

OPERATING PROCEDURE WITH VERSAHANDLERS (CONT'D)

Operation With The VersaHANDLER (Cont'd)

Gutter Brush Operation (If Equipped) (Cont'd)

Figure 101

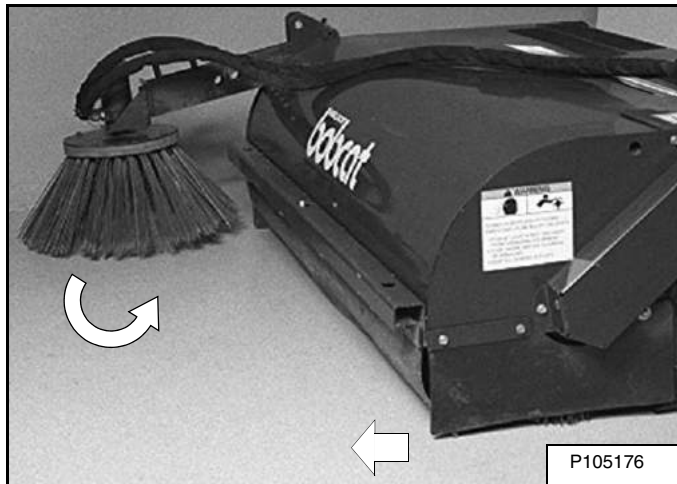

The gutter brush is designed to sweep debris from a curb or gutter out in front of the sweeper with the sweeper in a forward travel direction **[Figure 101]**.

If the sweeper is used in the reverse mode (scraping / sweeping) for any length of time, the gutter brush should be switched OFF and lifted to the transport position or removed from the sweeper.

The gutter brush can be mounted on either side of the sweeper. (See Gutter Brush on Page 23.)

OPERATING PROCEDURE WITH VERSAHANDLERS (CONT'D)

Removal

Hand Lever Bob-Tach

Lower the boom and put the attachment flat on the ground and lower or close the hydraulic equipment.

NOTE: In muddy conditions or to prevent the attachment from freezing to the ground, put the attachment on planks or blocks before removing the attachment from the VersaHANDLER.

Stop the engine and release auxiliary hydraulic pressure (if applicable). (See the VersaHANDLER's Operation & Maintenance Manual and Operator's Handbook for correct procedure.)

Exit the VersaHANDLER. (See Entering And Exiting The VersaHANDLER on Page 55.)

WARNING

Before you leave the operator's position:

- Put the travel Direction Control Lever and the Joystick in neutral.
- Engage the parking brake.
- Retract and lower the boom and attachment flat on the ground.
- Stop the engine. Raise the restraint bar (if equipped).

SEE THE MACHINE OPERATION & MAINTENANCE MANUAL FOR MORE INFORMATION.

W-2637-0607

Disconnect auxiliary hydraulic hoses. (See Hydraulic Quick Couplers on Page 60.)

Figure 102

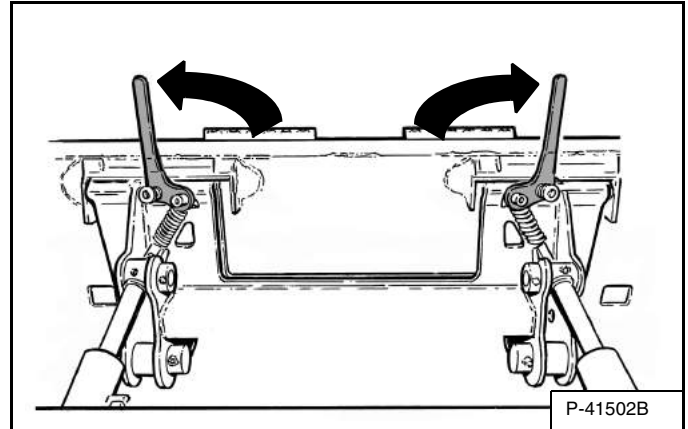

Pull the Bob-Tach levers up until they are fully raised (wedges fully raised) [Figure 102].

WARNING

Bob-Tach levers have spring tension. Hold lever tightly and release slowly. Failure to obey warning can cause injury.

W-2054-1285

Enter the VersaHANDLER. (See Entering And Exiting The VersaHANDLER on Page 55.)

Start the engine and release the parking brake.

Figure 103

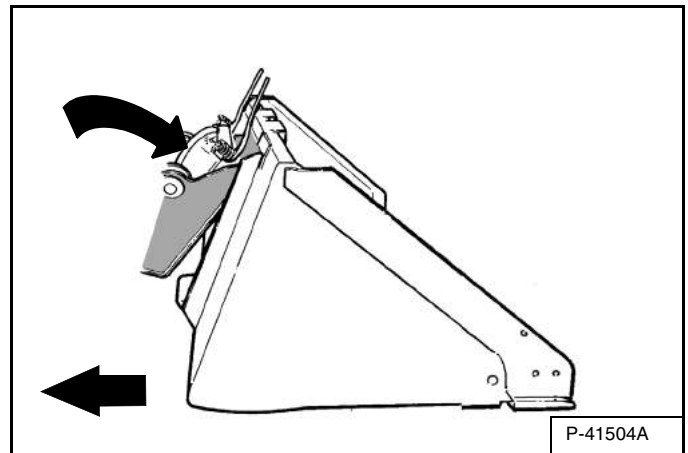

Tilt the Bob-Tach forward and drive the VersaHANDLER backward, away from the attachment [Figure 103].

OPERATING PROCEDURE WITH UTILITY WORK MACHINES

Approved Work Machine Models And Requirements

Figure 104

WORK MACHINE MODEL	54 SWEEPER	60 SWEEPER	72 SWEEPER
5600	X	X	
5610	X	X	

X = Approved

The chart [Figure 104] shows the approved sweeper models for each work machine model.

The warranty is void if this attachment is used on a non-approved carrier. See your Bobcat dealer for an updated list of approved carriers.



Never use attachments or buckets which are not approved by the Bobcat Company. Attachments and buckets for safe loads of specified densities are approved for each model. Unapproved attachments and buckets can cause injury or death.

W-2662-0108

Figure 105

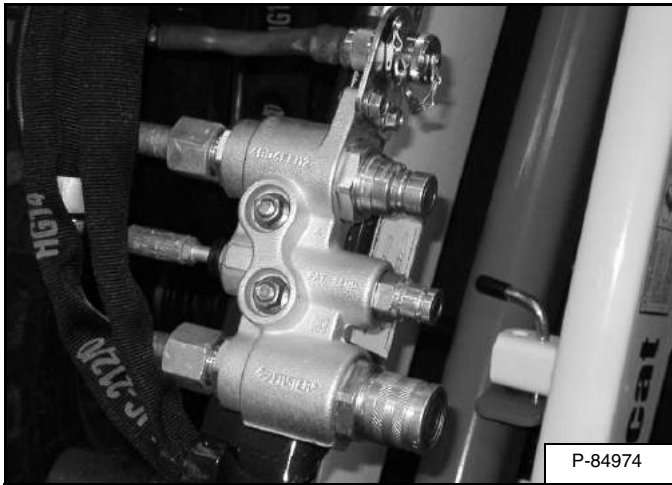

The work machine must be equipped with front auxiliary hydraulics [Figure 105] for proper operation of the sweeper. See your Bobcat work machine dealer for available kits for your model work machine.

OPERATING PROCEDURE WITH UTILITY WORK MACHINES (CONT'D)

Machine / Attachment Setup

NOTE: The work machine may be equipped with an earlier version hose guide or a removable hose guide mounting post. The earlier version hose guide and removable hose guide cannot be used together. See your Bobcat dealer for available kits.

Hose Guide Installation (Earlier Version)

Figure 106

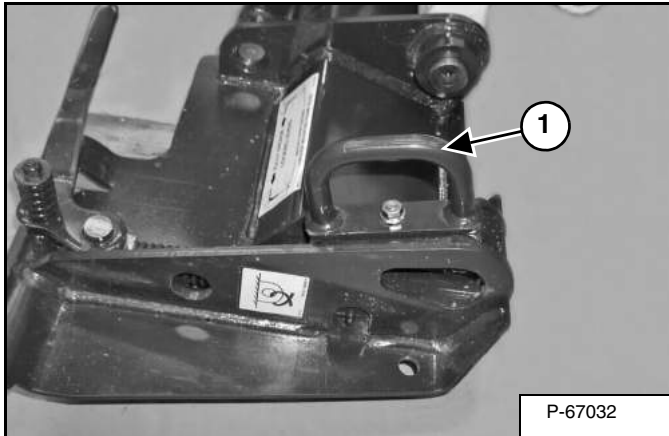

Install the hose guide (Item 1) [Figure 106] on the work machine.

NOTE: Hose guides are not included with the attachment. See your Bobcat dealer for available hose guide kits.

Hose Guide Installation (Removable - If Equipped)

Figure 107

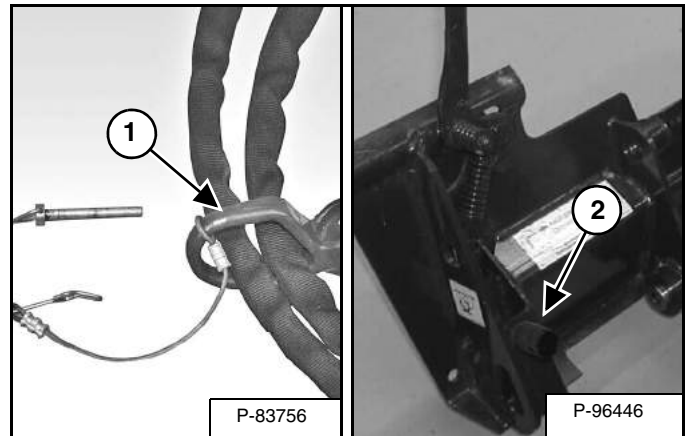

NOTE: Some attachments include a removable hose guide (Item 1) for use on work machines equipped with the mounting post (Item 2) [Figure 107]. Removable hose guide and mounting post kits are available through your Bobcat dealer.

NOTE: The removable hose guide is factory installed on the attachment for use with work machines. You may need to reorientate the removable hose guide for your specific work machine.

Installation of removable hose guide is done during hose routing. (See Hose Routing (Removable - If Equipped) on Page 77.)

Figure 108

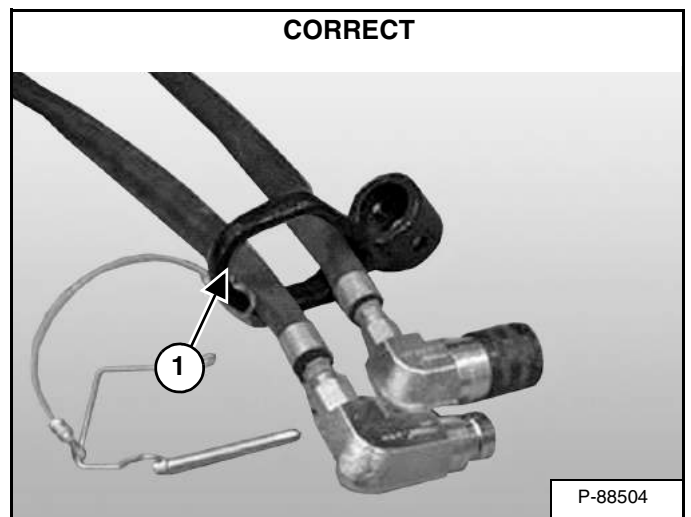

Shown is the correct orientation of the removable hose guide for the work machine (Item 1) [Figure 108].

OPERATING PROCEDURE WITH UTILITY WORK MACHINES (CONT'D)

Machine / Attachment Setup (Cont'd)

Hose Guide Installation (Removable - If Equipped) (Cont'd)

Use the following procedure to reorientate the removable hose guide for use on the work machine.

Figure 109

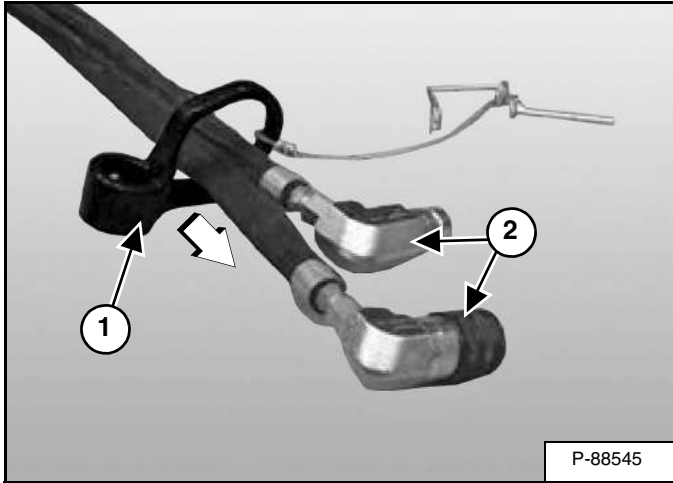

To change the removable hose guide (Item 1) [Figure 109] orientation, slide the removable hose guide off the hoses.

NOTE: It may be necessary to remove the hose couplers (Item 2) [Figure 109].

Figure 110

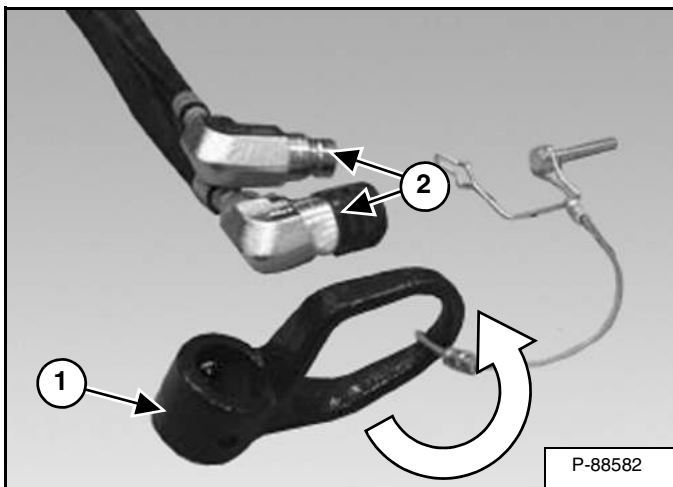

Flip the removable hose guide (Item 1) over to reverse its orientation on the hoses (Item 2) [Figure 110].

Figure 111

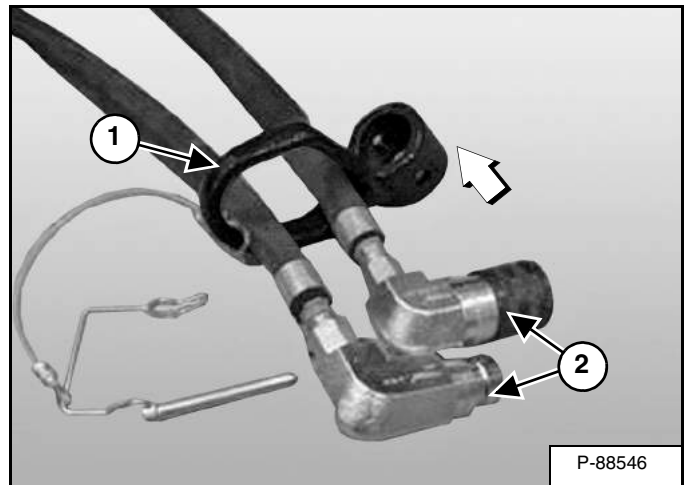

Slide the removable hose guide (Item 1) [Figure 111] back onto the hoses.

NOTE: If the couplers (Item 2) [Figure 111] were removed, reinstall at this time.

OPERATING PROCEDURE WITH UTILITY WORK MACHINES (CONT'D)

Entering And Exiting The Work Machine

Entering



AVOID INJURY OR DEATH

When operating the machine:

- Keep the seat belts fastened snugly.
- The arm rest must be lowered.
- Keep your feet and arms inside the cab.

W-2454-1102

Enter and exit the operator seat of the work machine from the left side.

NOTE: The left side of the work machine as viewed from the operator seat.

Figure 112



Enter the cab [Figure 112].

NOTE: Maintain three-point contact at all times while entering or exiting the work machine. Do not jump.

Figure 113

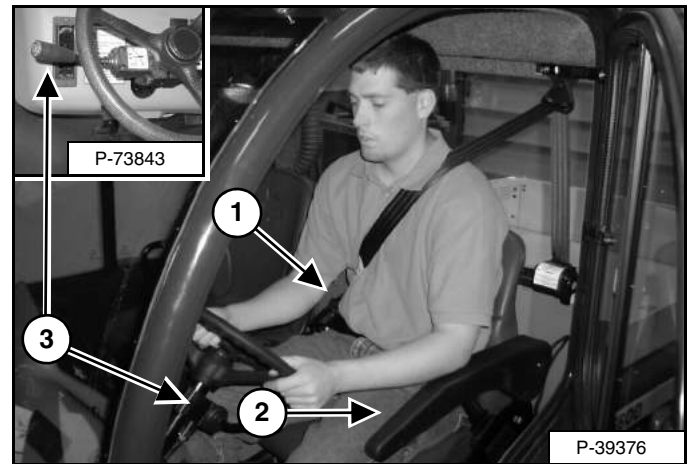

Fasten the seat belt snugly (Item 1) and lower the operator arm rest (Item 2) [Figure 113]. Adjust the belt so that it fits snug around the lower part of your hips. Passenger must also fasten seat belt.

Put the Travel Direction Control Lever (Item 3) [Figure 113] in PARK.

See the work machine's Operation & Maintenance Manual and Operator's Handbook for detailed information on operating the work machine.

Exiting

Put the Travel Direction Control Lever (Item 3) [Figure 113] in PARK.

Lower the lift arm and put the attachment flat on the ground.

Lower the attachment to the ground (if equipped).

Stop the engine.

Raise the operator arm rest, unfasten seat belt and remove the key.

Exit the work machine.



AVOID INJURY OR DEATH

Before you leave the operator's seat:

- Lower the lift arm, put attachment and implement (if equipped) flat on the ground.
- Put Travel Direction Control Lever in PARK.
- Stop the engine.
- Raise operator arm rest.

W-2740-0608

OPERATING PROCEDURE WITH UTILITY WORK MACHINES (CONT'D)

Installation

Hand Lever Bob-Tach

NOTE: The illustrations and instructions provided explain how to install a bucket attachment on to a work machine. Follow these same instructions if you are installing different attachments such as a grapple, tiller, combo bucket, etc.

The attachment mounting frame for the attachment has a top flange that is designed to receive the top edge of the Bob-Tach and the lower part of the frame is designed to receive the Bob-Tach wedges.



Warnings on the machine and in the manuals are for your safety. Failure to obey warnings can cause serious injury or death.

W-2744-0608

Always inspect the work machine's Bob-Tach and the attachment mounting frame before installation. See the work machine's Operation & Maintenance Manual. (See DAILY INSPECTION on Page 24.)

Figure 114

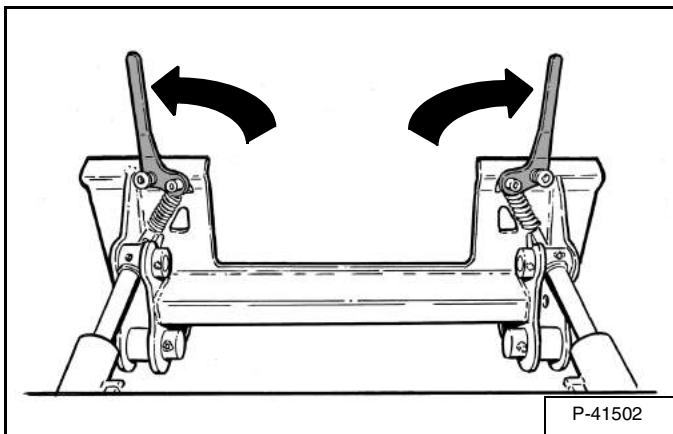

Pull the Bob-Tach levers up until they are fully raised (wedges fully raised) [Figure 114].

Enter the work machine. (See Entering And Exiting The Work Machine on Page 71.)

Start the engine.

Figure 115

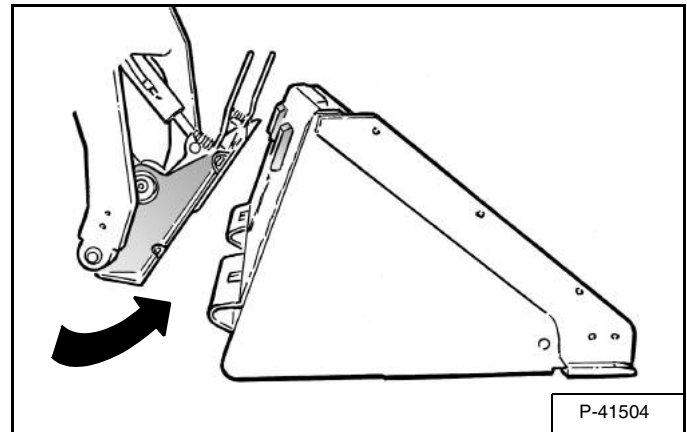

Lower the lift arm and tilt the Bob-Tach forward.

Drive the work machine slowly forward until the top edge of the Bob-Tach is completely under the top flange of the attachment mounting frame [Figure 115].

NOTE: Be sure the Bob-Tach levers do not hit the attachment.

Figure 116

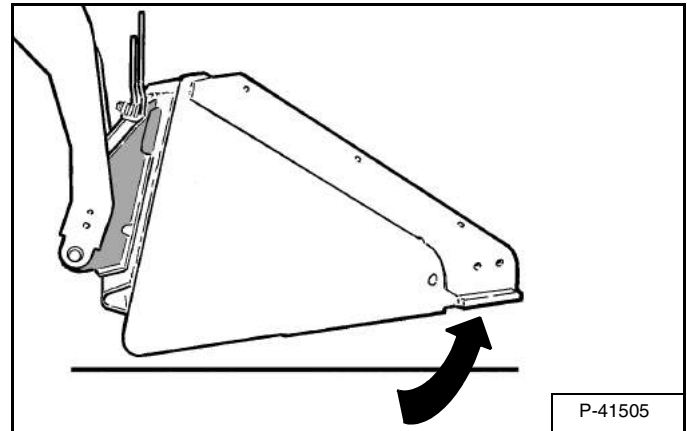

Tilt the Bob-Tach backward until the attachment is slightly off the ground [Figure 116]. This will cause the attachment mounting frame to fit up against the front of the Bob-Tach.

NOTE: When leaving the operator's seat to install an attachment, tilt the attachment until it is slightly off the ground.

Stop the engine and exit the work machine. (See Entering And Exiting The Work Machine on Page 71.)

OPERATING PROCEDURE WITH UTILITY WORK MACHINES (CONT'D)

Installation (Cont'd)

Hand Lever Bob-Tach (Cont'd)

! WARNING

AVOID INJURY OR DEATH

Before you leave the operator's seat:

- Lower the lift arm, put attachment and implement (if equipped) flat on the ground.
- Put Travel Direction Control Lever in PARK.
- Stop the engine.
- Raise operator arm rest.

W-2740-0608

Figure 117

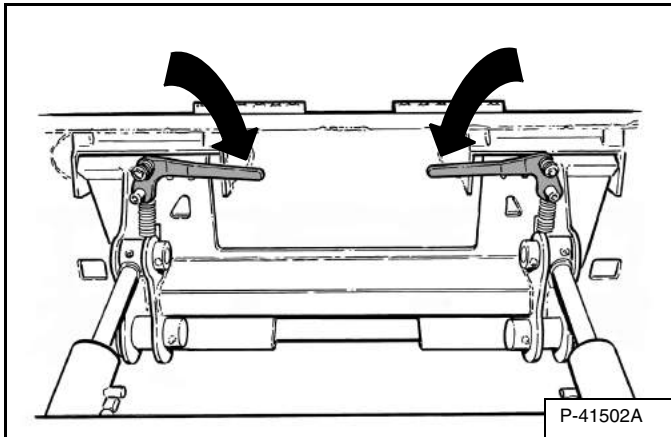

Push down on the Bob-Tach levers until they are fully engaged in the locked position [Figure 117] (wedges fully extended through the attachment mounting frame holes).

Figure 118

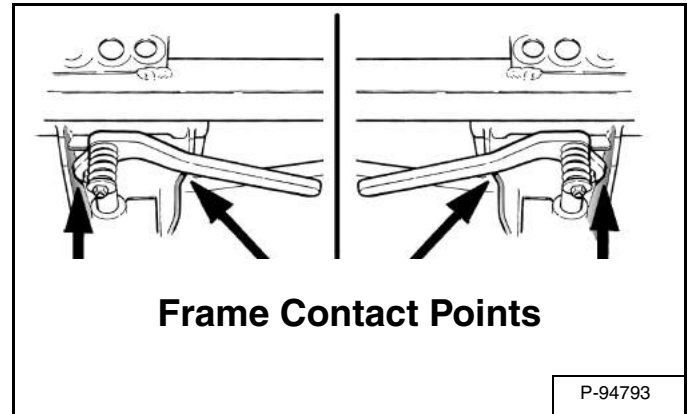

Both levers must contact the frame as shown when locked [Figure 118].

If both levers do not engage in the locked position, see your Bobcat dealer for maintenance.

! WARNING

AVOID INJURY OR DEATH

The Bob-Tach wedges must extend through the holes in the attachment mounting frame. Levers must be fully down and locked. Failure to secure wedges can allow attachment to come off.

W-2715-0208

Figure 119

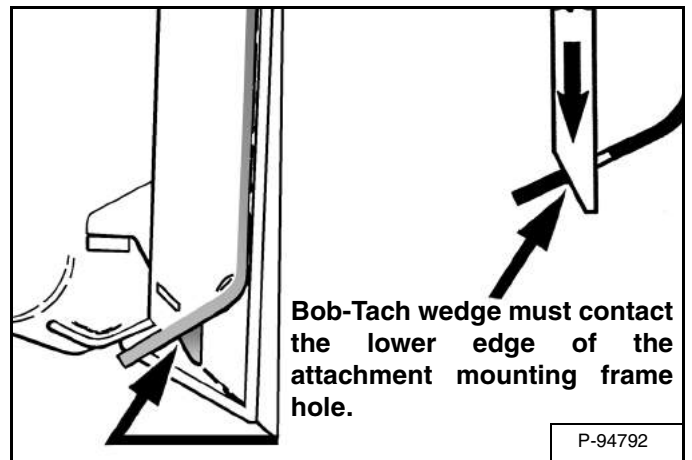

The wedges must extend through the holes in the attachment mounting frame, securely fastening the attachment to the Bob-Tach [Figure 119].

OPERATING PROCEDURE WITH UTILITY WORK MACHINES (CONT'D)

Installation (Cont'd)

Power Bob-Tach

! WARNING

Warnings on the machine and in the manuals are for your safety. Failure to obey warnings can cause serious injury or death.

W-2744-0608

This work machine may be equipped with a Power Bob-Tach.

Enter the work machine. (See Entering And Exiting The Work Machine on Page 71.)

Start the engine.

Figure 120

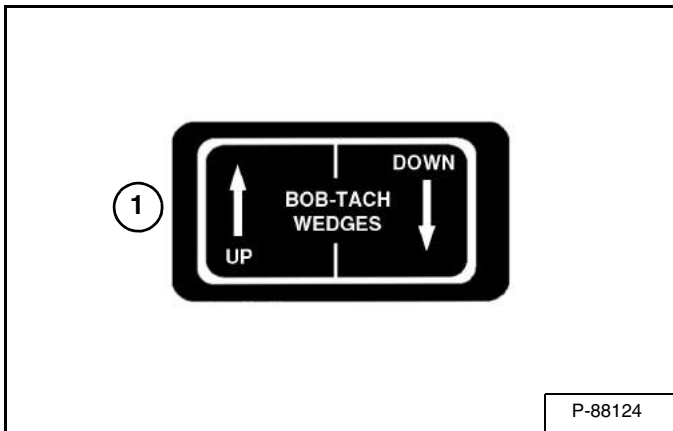
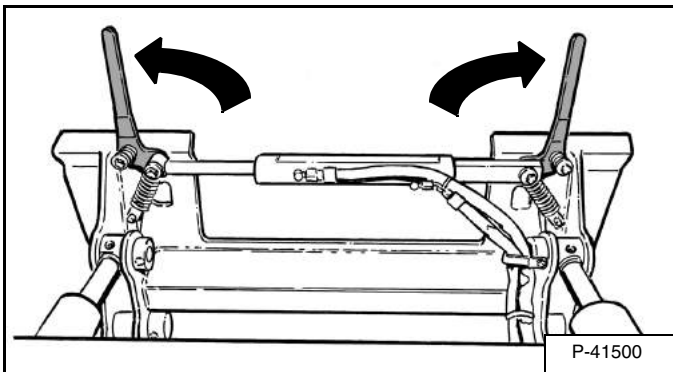
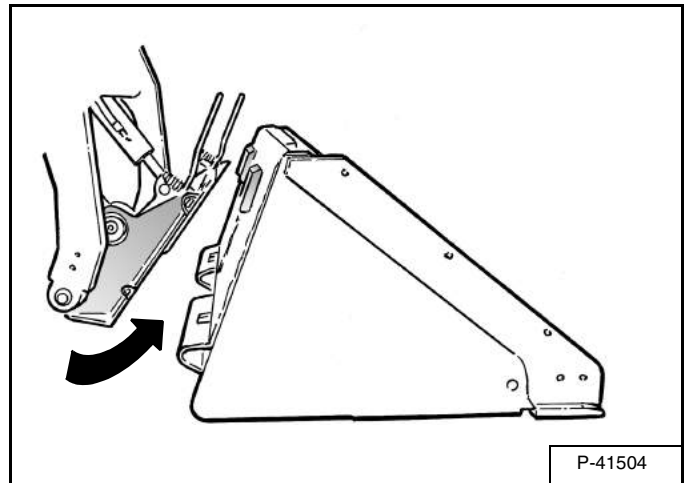

Figure 121



Push and hold the BOB-TACH “WEDGES UP” switch (Item 1) [Figure 120] until the levers are fully raised (wedges fully raised) [Figure 121].

Figure 122



Lower the lift arm and tilt the Bob-Tach slightly forward.

Drive the work machine slowly forward until the top edge of the Bob-Tach is completely under the top flange of the attachment mounting frame [Figure 122].

NOTE: Be sure the Bob-Tach levers do not hit the attachment.

Figure 123

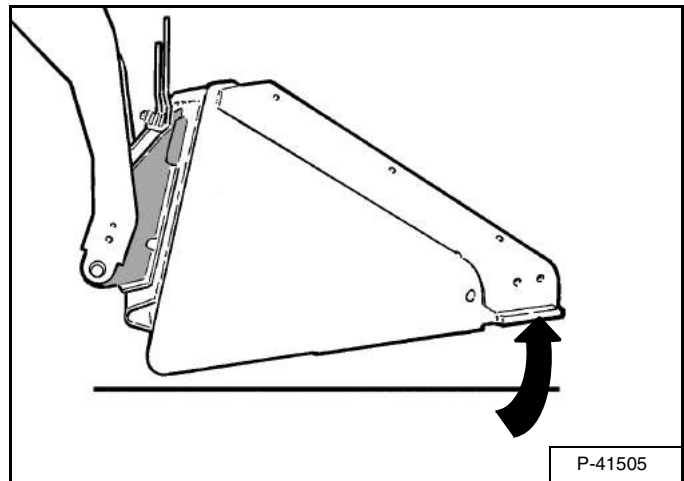

Tilt the Bob-Tach backward until the attachment is slightly off the ground [Figure 123]. This will cause the attachment mounting frame to fit up against the front of the Bob-Tach.

OPERATING PROCEDURE WITH UTILITY WORK MACHINES (CONT'D)

Installation (Cont'd)

Power Bob-Tach (Cont'd)

Figure 124

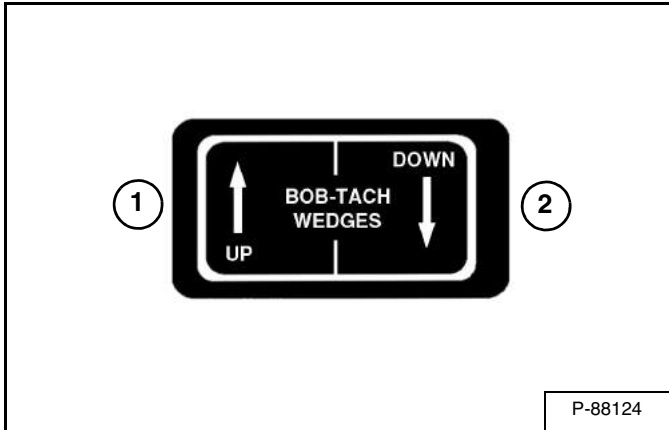

NOTE: The Power Bob-Tach system has continuous pressurized hydraulic oil to keep the wedges in the engaged position and prevent attachment disengagement. Because the wedges can slowly lower, the operator may need to reactivate the switch (BOB-TACH “WEDGES UP”) to be sure both wedges are fully raised before installing the attachment.

Push and hold the BOB-TACH “WEDGES UP” switch (Item 1) [Figure 124] until the levers are fully raised (wedges fully raised).

Figure 125

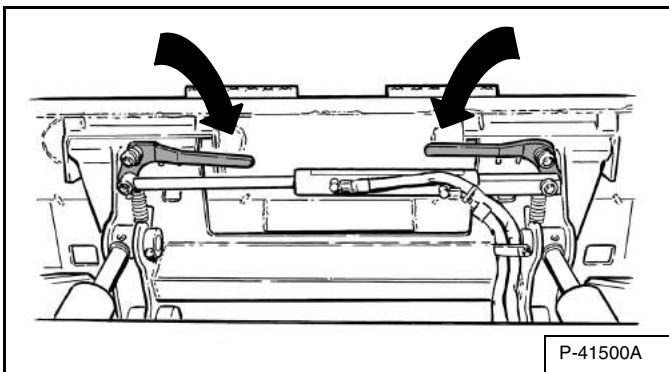

Push and hold the BOB-TACH “WEDGES DOWN” switch (Item 2) [Figure 124] until the levers are fully engaged in the locked position [Figure 125] (wedges fully extended through the attachment mounting frame holes).

Figure 126

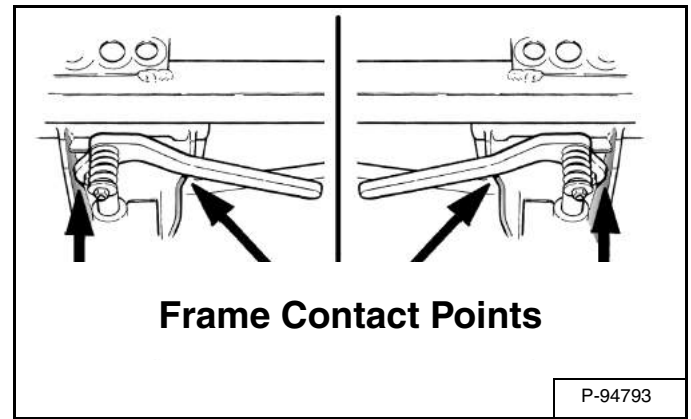

Both levers must contact the frame as shown when locked [Figure 126].

If both levers do not engage in the locked position, see your Bobcat dealer for maintenance.

WARNING

AVOID INJURY OR DEATH

The Bob-Tach wedges must extend through the holes in the attachment mounting frame. Levers must be fully down and locked. Failure to secure wedges can allow attachment to come off.

W-2715-0208

Figure 127

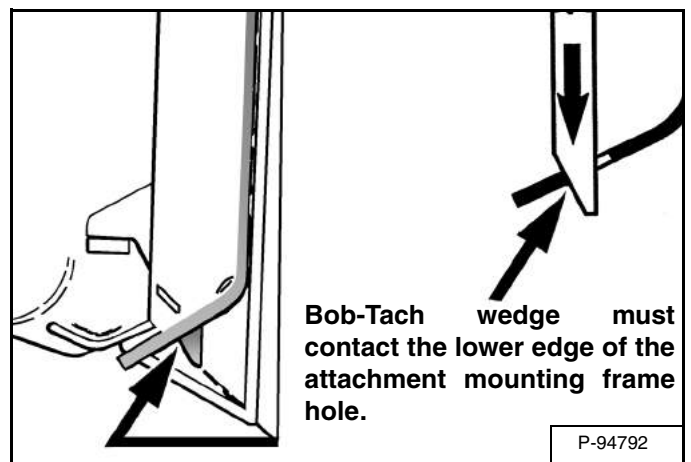

The wedges must extend through the holes in the attachment mounting frame, securely fastening the attachment to the Bob-Tach [Figure 127].

Lower the lift arm and put the attachment flat on the ground.

OPERATING PROCEDURE WITH UTILITY WORK MACHINES (CONT'D)

Installation (Cont'd)

Power Bob-Tach (Cont'd)

Stop the engine and exit the work machine. (See Entering And Exiting The Work Machine on Page 71.)



WARNING

AVOID INJURY OR DEATH

Before you leave the operator's seat:

- Lower the lift arm, put attachment and implement (if equipped) flat on the ground.
- Put Travel Direction Control Lever in **PARK**.
- Stop the engine.
- Raise operator arm rest.

W-2740-0608

OPERATING PROCEDURE WITH UTILITY WORK MACHINES (CONT'D)

Installation (Cont'd)

NOTE: Your work machine may be equipped with an earlier version hose guide or a removable hose guide mounting post. The earlier version hose guide and removable hose guide cannot be used together. See your Bobcat dealer for available kits.

Hose Routing (Earlier Version)

Figure 128

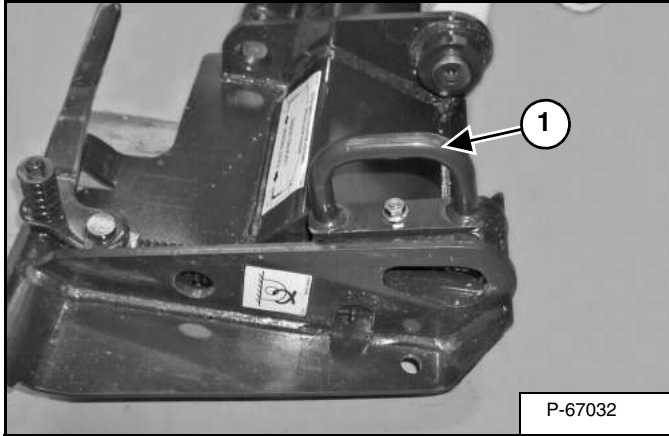

Route hoses through hose guide (Item 1) [Figure 128] and connect quick couplers to the work machine. (See Hydraulic Quick Couplers on Page 81.)

Hose Routing (Removable - If Equipped)

Figure 129

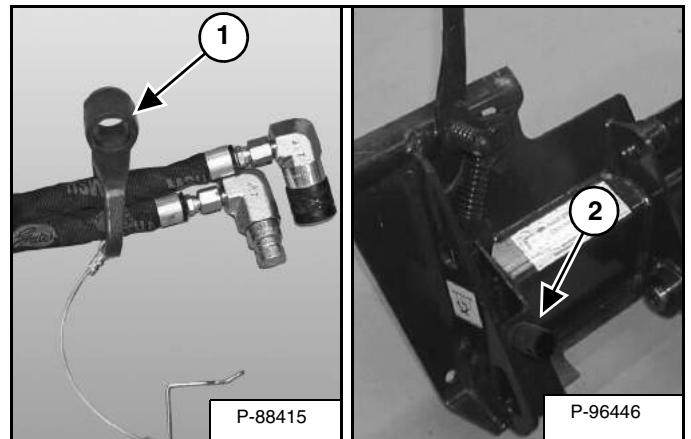

NOTE: Some attachments include removable hose guide (Item 1) for use on work machines equipped with a mounting post (Item 2) [Figure 129]. Removable hose guide and mounting post kits are available through your Bobcat dealer.

Figure 130

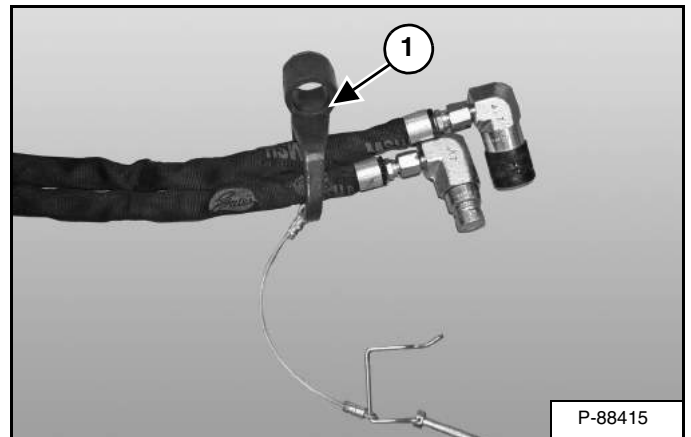

The removable hose guide (Item 1) [Figure 130] is pre-installed on the hydraulic hoses. If the orientation of the hose guide needs to be changed, (See Hose Guide Installation (Removable - If Equipped) on Page 69.)

OPERATING PROCEDURE WITH UTILITY WORK MACHINES (CONT'D)

Installation (Cont'd)

Hose Routing (Removable - If Equipped) (Cont'd)

Figure 131

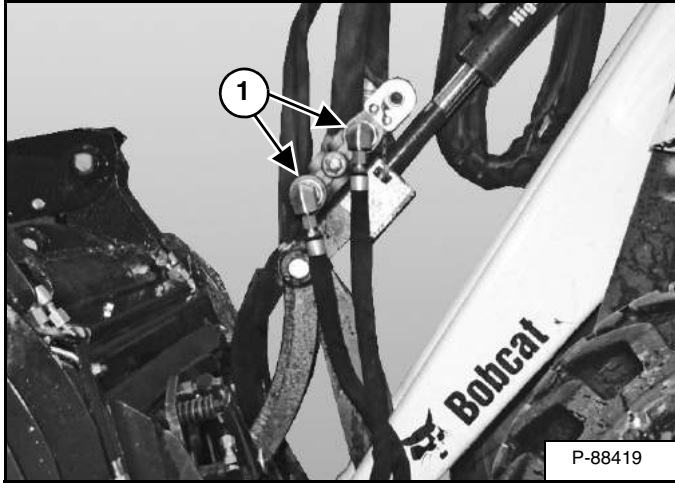

Connect the hydraulic quick couplers to the work machine (Item 1) [Figure 131]. (See Hydraulic Quick Couplers on Page 81.)

Figure 132

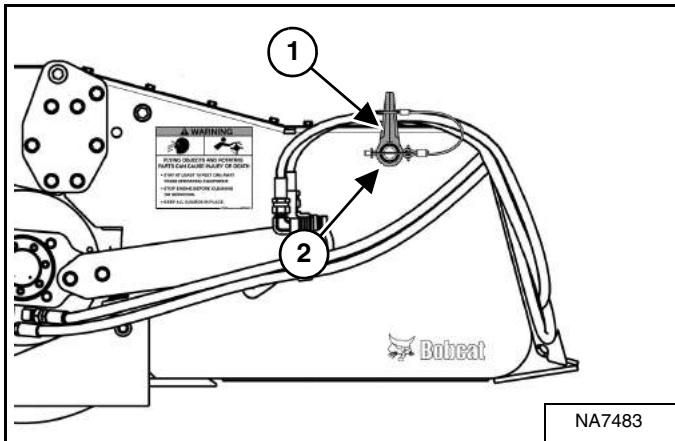

Remove the removable hose guide (Item 1) from the storage post (Item 2) [Figure 132] (if equipped).

Figure 133

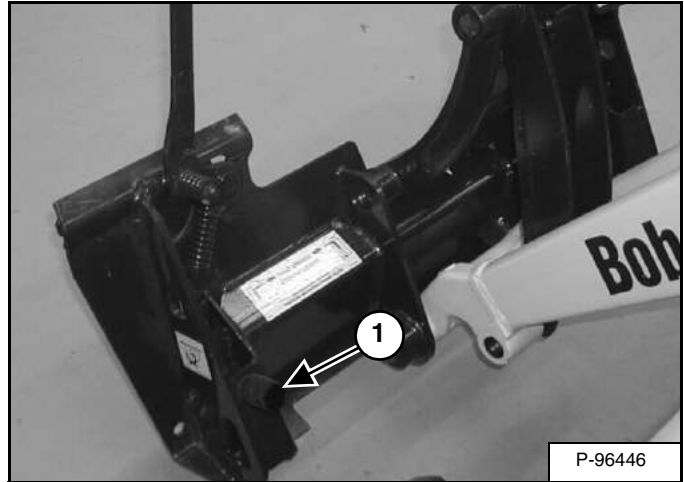

Install the removable hose guide onto the mounting post (Item 1) [Figure 133] located on the back of the Bob-Tach.

Figure 134

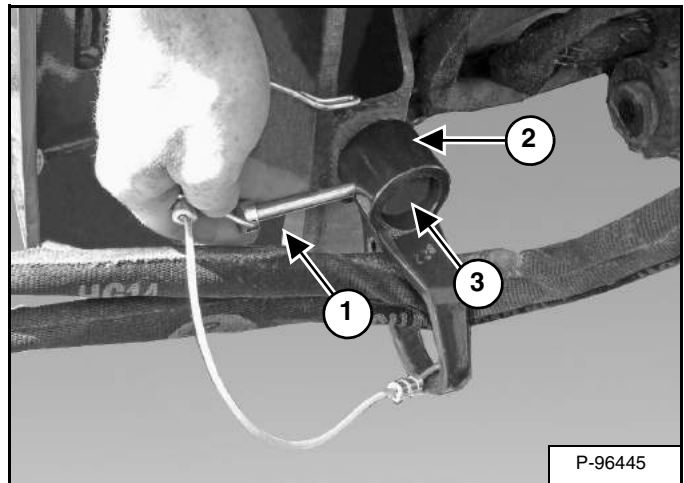

Insert lock pin (Item 1) through the removable hose guide (Item 2) and mounting post (Item 3) [Figure 134].

OPERATING PROCEDURE WITH UTILITY WORK MACHINES (CONT'D)

Installation (Cont'd)

Hose Routing (Removable - If Equipped) (Cont'd)

Figure 135

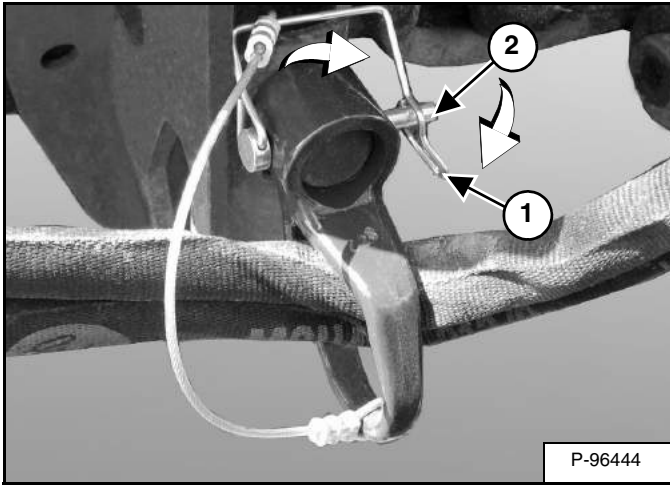

Secure the latch eye (Item 1) onto the lock pin (Item 2) **[Figure 135]**.

Figure 136



Hose routing for work machines should be similar as shown **[Figure 136]**.

OPERATING PROCEDURE WITH UTILITY WORK MACHINES (CONT'D)

Installation (Cont'd)

For First Time Installation

New attachments and new work machines are factory equipped with flush face couplers. If installing an attachment equipped with poppet style couplers, the attachment couplers will have to be changed to match the work machine. See your Bobcat dealer for parts information.

IMPORTANT

- **Thoroughly clean the quick couplers before making connections. Dirt can quickly damage the system.**
- **Contain and dispose of any oil leakage in an environmentally safe manner.**

I-2278-0608

With the work machine engine off and using the hose guides (if equipped), route the attachment hydraulic hoses to the machine. Connect the attachment hydraulic quick couplers to the work machine couplers. (See Hydraulic Quick Couplers on Page 81.)

Verify that the attachment hydraulic hoses are not twisted or contacting any moving parts of the work machine or attachment.

NOTE: It may be necessary to loosen the quick couplers on the attachment hydraulic hoses to remove any twists in the hoses.

WARNING

AVOID INJURY OR DEATH

Wear safety glasses to prevent eye injury when any of the following conditions exist:

- **When fluids are under pressure.**
- **Flying debris or loose material is present.**
- **Engine is running.**
- **Tools are being used.**

W-2019-0907

Loosen the quick coupler connections on the attachment hydraulic hoses while connected to the work machine. Do not remove the quick couplers.

Rotate the attachment hydraulic hoses as needed so the hoses are not twisted or contacting any moving parts of the work machine or attachment.

With the twist(s) removed from the hydraulic hoses, tighten the attachment quick coupler connections while the couplers are still connected to the work machine. This will help hold the hydraulic hoses in position while tightening.

Tighten the quick couplers connections to 63 N•m (46 ft-lb) torque before starting the work machine.

Enter the work machine. (See Entering And Exiting The Work Machine on Page 71.)

Start the engine and release the parking brake.

Engage auxiliary hydraulics. (See the work machine's Operation & Maintenance Manual and Operator's Handbook for correct procedure.)

WARNING

AVOID INJURY OR DEATH

Diesel fuel or hydraulic fluid under pressure can penetrate skin or eyes, causing serious injury or death. Fluid leaks under pressure may not be visible. Use a piece of cardboard or wood to find leaks. Do not use your bare hand. Wear safety goggles. If fluid enters skin or eyes, get immediate medical attention from a physician familiar with this injury.

W-2072-0807

Check the attachment hydraulic quick coupler connections for leaks.

OPERATING PROCEDURE WITH UTILITY WORK MACHINES (CONT'D)

Hydraulic Quick Couplers

IMPORTANT

- Thoroughly clean the quick couplers before making connections. Dirt can quickly damage the system.
- Contain and dispose of any oil leakage in an environmentally safe manner.

I-2278-0608

New attachments and new work machines are factory equipped with flush face couplers. If installing an attachment equipped with poppet style couplers, the attachment couplers will have to be changed to match the work machine. See your Bobcat dealer for parts information.

NOTE: Make sure the quick couplers are fully engaged. If the quick couplers do not fully engage, check to see that the couplers are the same size and type.

Figure 137

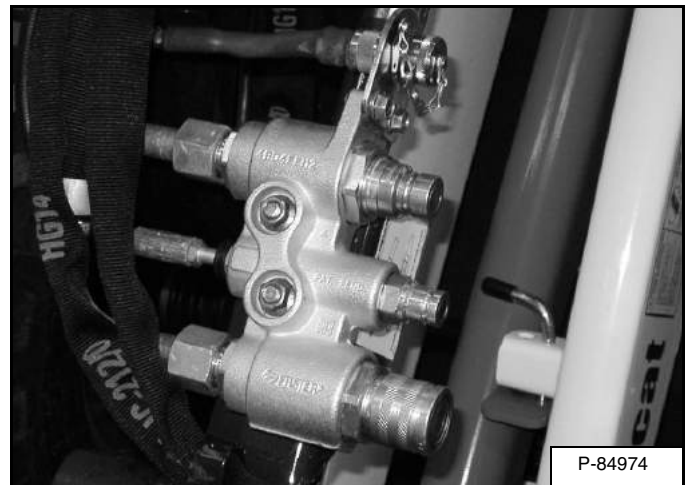

! WARNING

AVOID BURNS

Hydraulic fluid, tubes, fittings and quick couplers can get hot when running machine and attachments. Be careful when connecting and disconnecting quick couplers.

W-2220-0396

To Connect:

Remove any dirt or debris from the surface of both the male and female couplers, and from the outside diameter of the male coupler. Visually check the couplers for corroding, cracking, damage, or excessive wear. If any of these conditions exist, the coupler(s) must be replaced [Figure 137].

Install the male coupler into the female coupler. Full connection is made when the ball release sleeve slides forward on the female coupler [Figure 137].

NOTE: Check that the attachment hydraulic hoses are not twisted or contacting any moving parts of the work machine or attachment. (See For First Time Installation on Page 80.) for proper adjustment.

To Disconnect:

Relieve hydraulic pressure. (See the work machine's Operation & Maintenance Manual and Operator's Handbook for correct procedure.)

Push the couplers together, retract the sleeve on the female coupler until the couplers disconnect.

OPERATING PROCEDURE WITH UTILITY WORK MACHINES (CONT'D)

Hydraulic Quick Couplers (Cont'd)

Figure 138

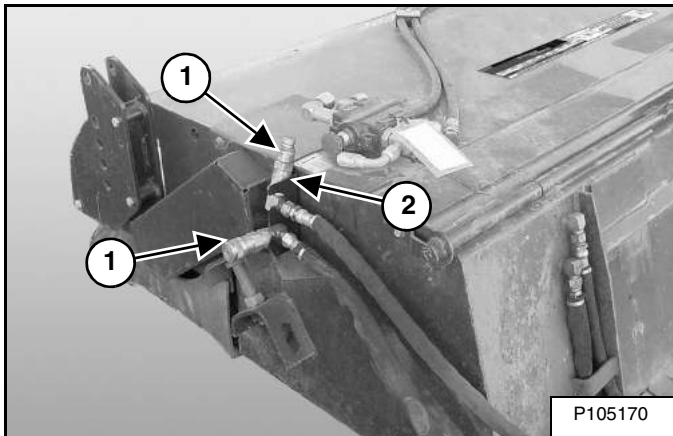

When the sweeper is not connected to the loader, install the hoses (Item 1) into the hose hanger bracket (Item 2) [Figure 138] (if equipped).

Figure 139

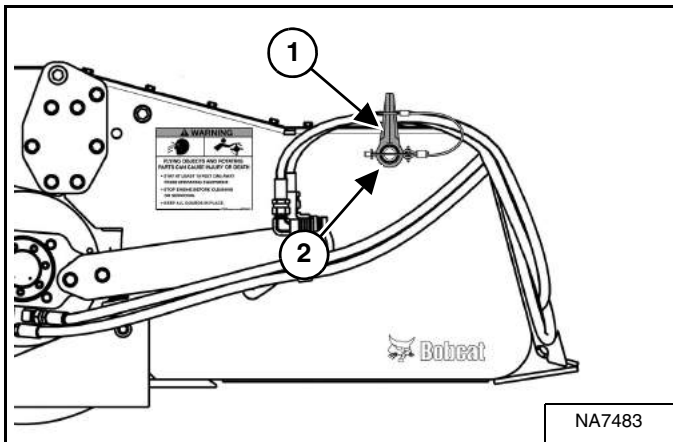

When the sweeper is not connected to the loader, install the removable hose guide (Item 1) onto the storage post (Item 2) [Figure 139] (if equipped).

Control Functions

Enter the work machine. (See Entering And Exiting The Work Machine on Page 71.)

Start the engine.

Engage auxiliary hydraulics. (See the work machine's Operation & Maintenance Manual and Operator's Handbook for correct procedure.)

NOTE: The auxiliary hydraulics must be activated prior to attachment operation.

NOTE: Do not operate sweeper using high-flow auxiliary hydraulics.

Figure 140

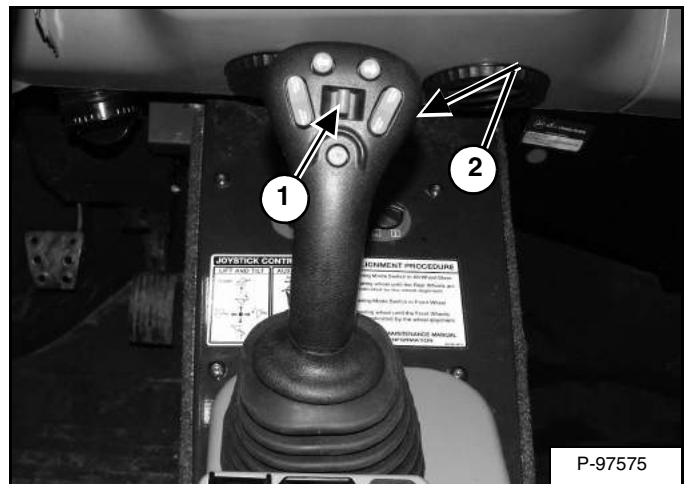

Push the front button (Item 2) on the joystick once for continuous flow, the brush will rotate counterclockwise to sweep in a forward direction. Push the button (Item 2) a second time to disengage continuous flow (detent). To reverse the sweeper rotation, press the switch (Item 1) [Figure 140] to the left.

Continuous (Detent) Reverse Direction Operation

To activate continuous reverse sweeper rotation, hold the switch (Item 1) to the left and press the button (Item 2) [Figure 140].

To deactivate continuous reverse operation, push the button (Item 2) [Figure 140] a second time.

OPERATING PROCEDURE WITH UTILITY WORK MACHINES (CONT'D)

Operation With The Work Machine

Sweeper Operation

Figure 141

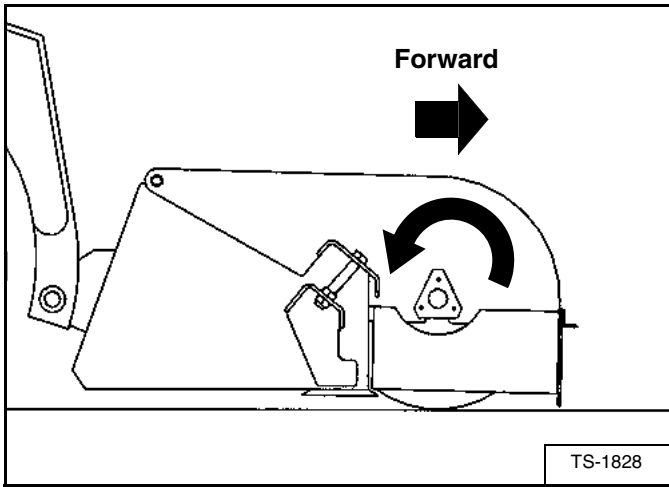

Lower the sweeper slowly to the surface. Make sure the cutting edge of the sweeper bucket is just above the surface, level with the surface and the brushes are in contact with the surface [Figure 141].

Put the work machine lift arm in the float position and use the tilt function to level the sweeper. (See the work machine's Operation & Maintenance Manual and Operator's Handbook for correct procedure.)

WARNING

AVOID INJURY OR DEATH

- Bystanders must keep at least 3 m (10 ft) away from the machine and attachment when operating.
- Never leave the operating position when the engine is running.

W-2320-0910

Figure 142

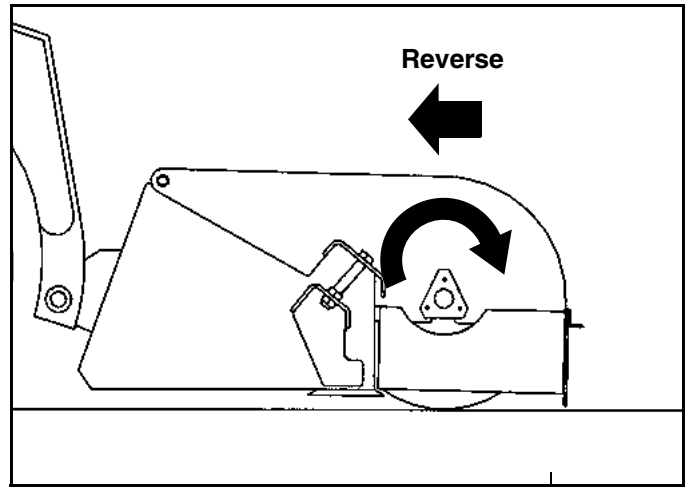

If the debris is packed (or stuck) on the surface and the broom will not sweep it up, reverse broom rotation. (See Control Functions on Page 82.) Lower the cutting edge to the surface and move the work machine backward. The attachment cutting edge will scrape the surface while the broom sweeps the debris into the bucket [Figure 142].

WARNING

AVOID INJURY OR DEATH

Wear safety glasses to prevent eye injury when any of the following conditions exist:

- When fluids are under pressure.
- Flying debris or loose material is present.
- Engine is running.
- Tools are being used.

W-2019-0907

OPERATING PROCEDURE WITH UTILITY WORK MACHINES (CONT'D)

Operation With The Work Machine (Cont'd)

Sweeper Operation (Cont'd)

Figure 143

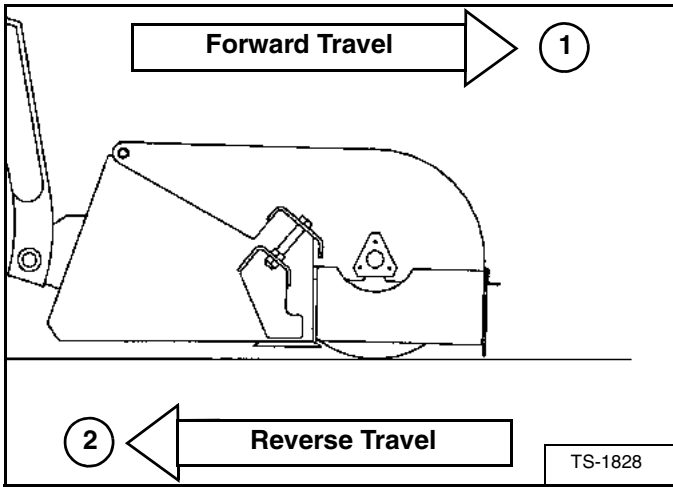
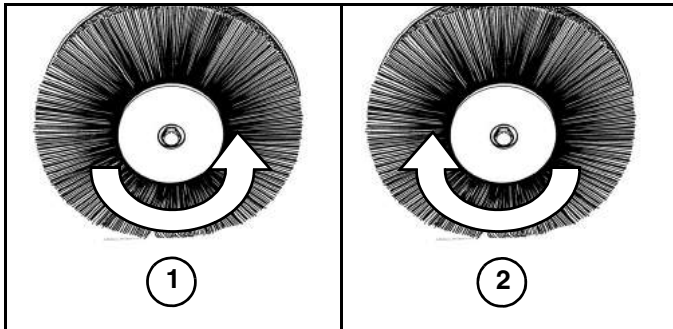

Figure 144



Forward Travel

When traveling in the forward direction (Item 1) [Figure 143] operate the sweeper in the counterclockwise direction (Item 1) [Figure 144] with the cutting edge slightly above the surface to be swept.

NOTE: Traveling in the forward direction (Item 1) [Figure 143] reduces wear on cutting edge and reduces scratching of swept surface.

Reverse Travel

When traveling in the reverse direction (Item 2) [Figure 143] operate the sweeper in the clockwise direction (Item 2) [Figure 144] with the cutting edge set on the surface to be swept.

Bristles Types

1. High Carbon Wire - For use with aggressive conditions such as mud, rocks, etc.
2. Polypropylene - For use with normal conditions such as dirt, sand, leaves, etc.
3. Combination Of Bristles - For use with varying conditions such as dry sweeping. (Not as effective for aggressive conditions.)

Figure 145

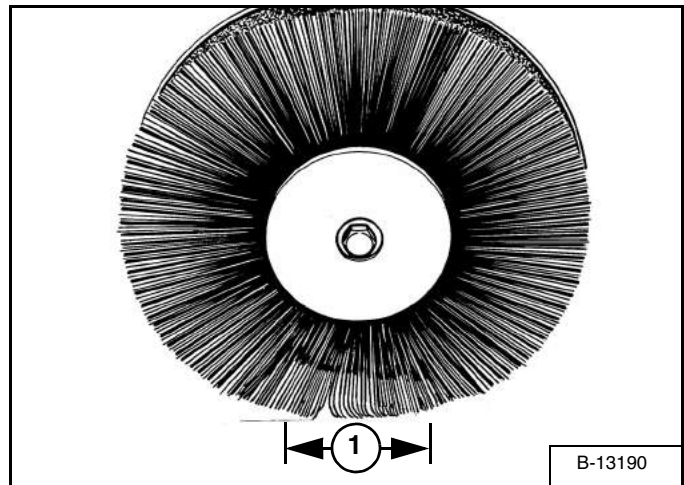

A 50 - 76 mm (2 - 3 in) (Item 1) [Figure 145] pattern is recommended for ground contact and allows the tips, or ends of the bristles, to dig and break up the debris then throw the debris off the swept surface into the bucket.

Excessive down pressure can result in the following problems which will reduce broom performance:

1. The sides of the bristles trying to dig and break up the debris and cause increased wear at the contact point.
2. The bristles are stressed and can break off in full length pieces.

OPERATING PROCEDURE WITH UTILITY WORK MACHINES (CONT'D)

Operation With The Work Machine (Cont'd)

Dumping The Sweeper

WARNING

AVOID INJURY OR DEATH

LIFT RESTRICTION - While dumping a loaded sweeper, the lowest part of the sweeper should not exceed 0,3 m (1 ft) from the ground. Tipping can result.

Lower sweeper to ground and stop engine before cleaning, servicing or repairing.

Consult the LIFT RESTRICTION decal before lifting or dumping.

W-2525-0910

NOTE: (See ATTACHMENT SIGNS (DECALS) on Page 18.) for location of lift restriction decal.

Figure 146

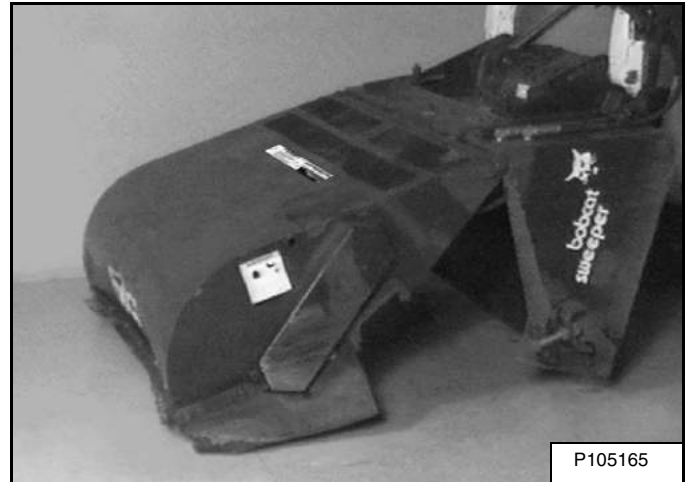

Lift the attachment off the ground. Tilt the sweeper attachment forward until it is empty [Figure 146]. The broom can be rotated to help empty the attachment.

OPERATING PROCEDURE WITH UTILITY WORK MACHINES (CONT'D)

Operation With The Work Machine (Cont'd)

Gutter Brush Operation (If Equipped)

Figure 147

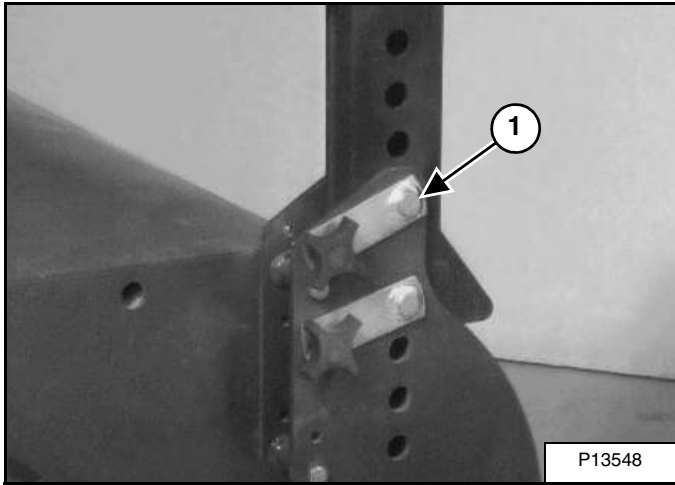

Figure 149

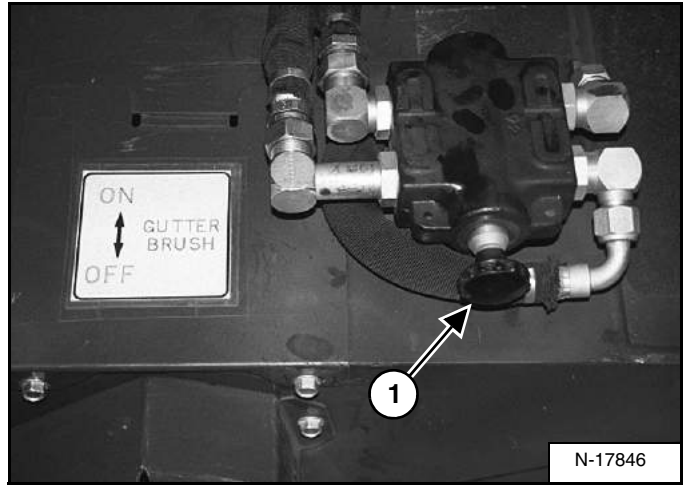

Figure 148



Remove the transport pin (Item 1) [Figure 147] and lower the gutter brush to the sweeping position [Figure 148].

Push the knob (Item 1) [Figure 149] into the ON position. The gutter brush will start to turn with the sweeper brush when the auxiliary hydraulics is engaged.

Figure 150

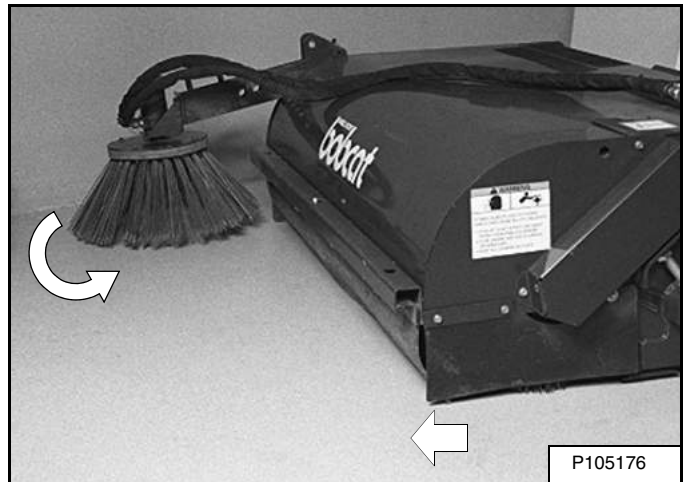

The gutter brush is designed to sweep debris from a curb or gutter out in front of the sweeper with the sweeper in a forward travel direction [Figure 150].

If the sweeper is used in the reverse mode (scraping / sweeping) for any length of time, the gutter brush should be switched OFF and lifted to the transport position or removed from the sweeper.

The gutter brush can be mounted on either side of the sweeper. (See Gutter Brush on Page 23.)

OPERATING PROCEDURE WITH UTILITY WORK MACHINES (CONT'D)

Removal

Hose Removal (Earlier Version)

Disconnect the quick couplers to the work machine. (See Hydraulic Quick Couplers on Page 81.)

Figure 151

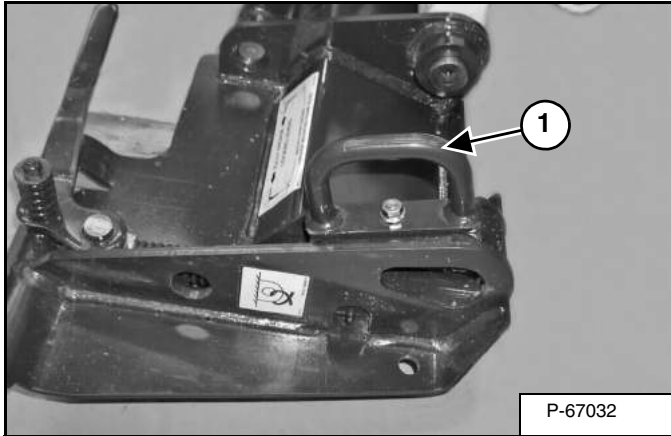

Slide the hoses through hose guide (Item 1) [Figure 151].

Hose Removal (Removable - If Equipped)

Figure 152

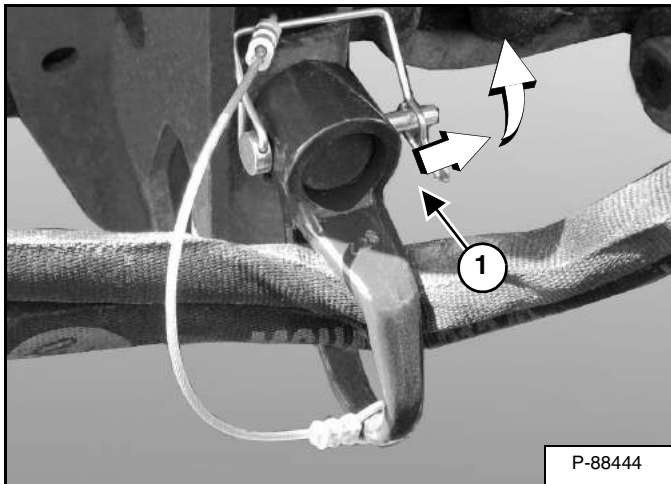

Unlatch eyelet (Item 1) [Figure 152] from the lock pin.

Figure 153

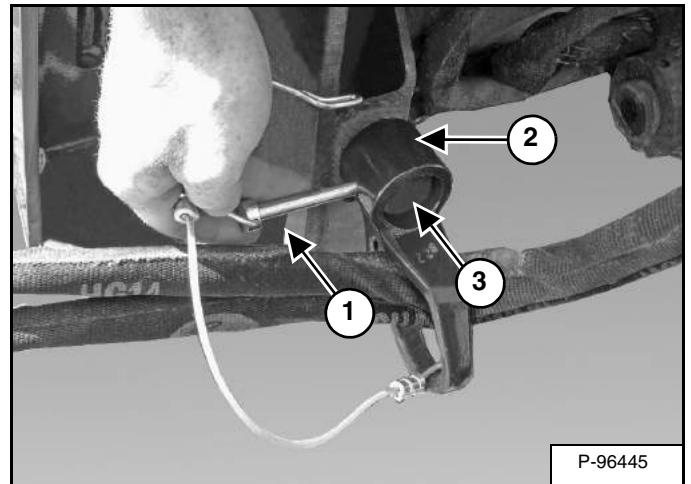

Remove the lock pin (Item 1) from the removable hose guide (Item 2) and mounting post (Item 3) [Figure 153].

Figure 154

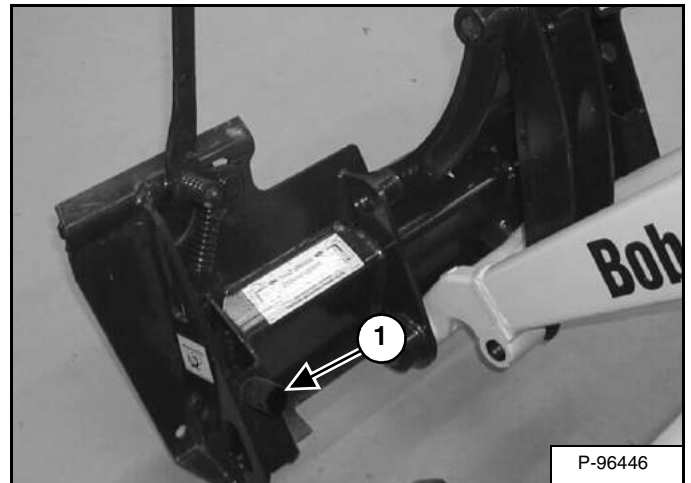

Remove the removable hose guide from the mounting post (Item 1) [Figure 154].

Disconnect the hydraulic quick couplers. (See Hydraulic Quick Couplers on Page 81.)

OPERATING PROCEDURE WITH UTILITY WORK MACHINES (CONT'D)

Removal (Cont'd)

Hose Removal (Removable - If Equipped) (Cont'd)

Figure 155

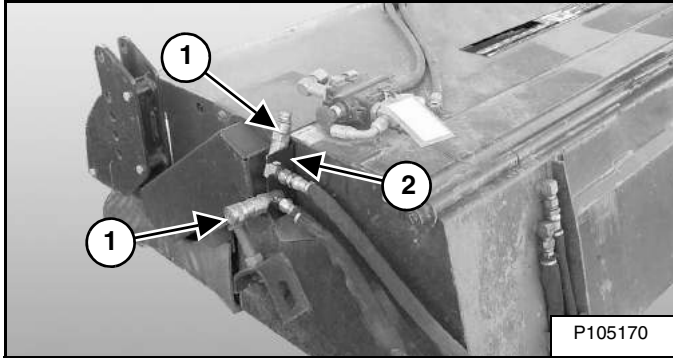

When the sweeper is not connected to the work machine, install the hoses (Item 1) into the hose hanger bracket (if equipped) (Item 2) [Figure 155].

Figure 156

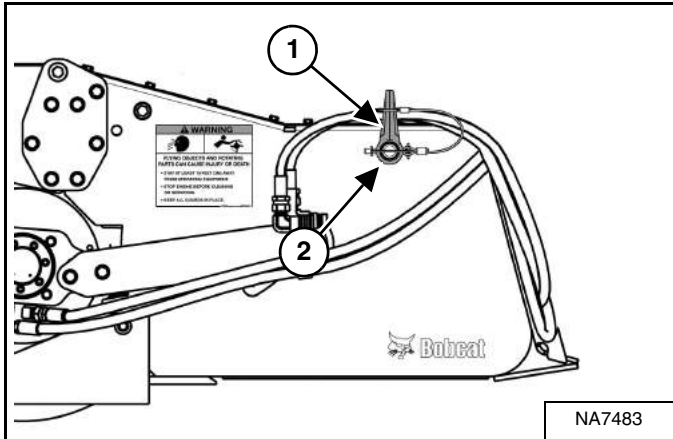

When the sweeper is not connected to the loader, install the removable hose guide (Item 1) onto the storage post (Item 2) [Figure 156] (if equipped).

OPERATING PROCEDURE WITH UTILITY WORK MACHINES (CONT'D)

Removal (Cont'd)

Hand Lever Bob-Tach

Lower the lift arm and put the attachment flat on the ground. Lower or close the hydraulic equipment (if equipped).

NOTE: In muddy conditions or to prevent the attachment from freezing to the ground, put the attachment on planks or blocks before removing the attachment from the work machine.

Stop the engine and release auxiliary hydraulic pressure (if applicable). (See the work machine's Operation & Maintenance Manual and Operator's Handbook for correct procedure.)

Exit the work machine. (See Entering And Exiting The Work Machine on Page 71.)



AVOID INJURY OR DEATH

Before you leave the operator's seat:

- Lower the lift arm, put attachment and implement (if equipped) flat on the ground.
- Put Travel Direction Control Lever in PARK.
- Stop the engine.
- Raise operator arm rest.

W-2740-0608

Disconnect auxiliary hydraulic hoses. (See Hydraulic Quick Couplers on Page 81.)

Figure 157

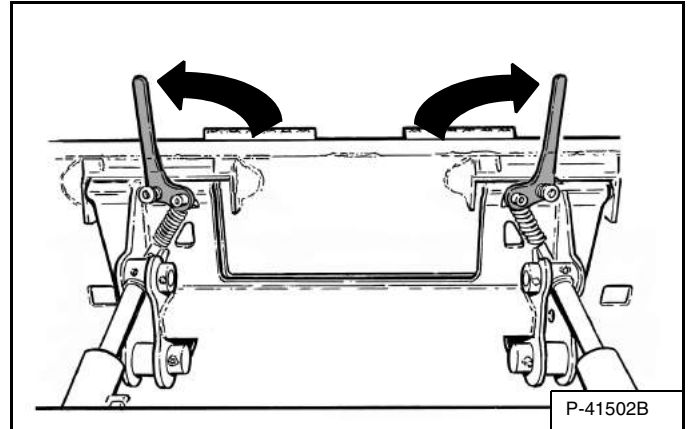

Pull the Bob-Tach levers up until they are fully raised (wedges fully raised) [Figure 157].



Bob-Tach levers have spring tension. Hold lever tightly and release slowly. Failure to obey warning can cause injury.

W-2054-1285

Enter the work machine. (See Entering And Exiting The Work Machine on Page 71.)

Start the engine.

Figure 158

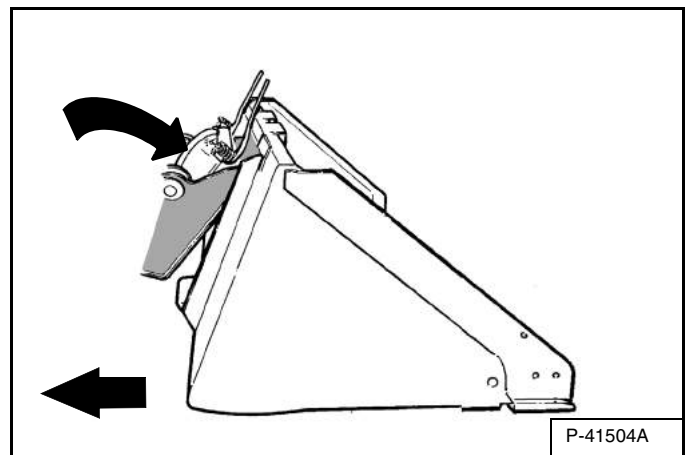

Tilt the Bob-Tach forward and drive the work machine backward, away from the attachment [Figure 158].

OPERATING PROCEDURE WITH UTILITY WORK MACHINES (CONT'D)

Removal (Cont'd)

Power Bob-Tach

Lower the lift arm and put the attachment flat on the ground. Lower or close the hydraulic equipment.

NOTE: In muddy conditions or to prevent the attachment from freezing to the ground, put the attachment on planks or blocks before removing the attachment from the work machine.

Stop the engine and release auxiliary hydraulic pressure (if applicable). (See the work machine's Operation & Maintenance Manual and Operator's Handbook for correct procedure.)

Exit the work machine. (See Entering And Exiting The Work Machine on Page 71.)

WARNING

AVOID INJURY OR DEATH

Before you leave the operator's seat:

- Lower the lift arm, put the attachment flat on the ground.
- Put Travel Direction Control Lever in PARK.
- Stop the engine.
- Raise operator arm rest.

W-2443-1102

Disconnect auxiliary hydraulic hoses. (See Hydraulic Quick Couplers on Page 81.)

Enter the work machine. (See Entering And Exiting The Work Machine on Page 71.)

Start the engine.

Figure 159

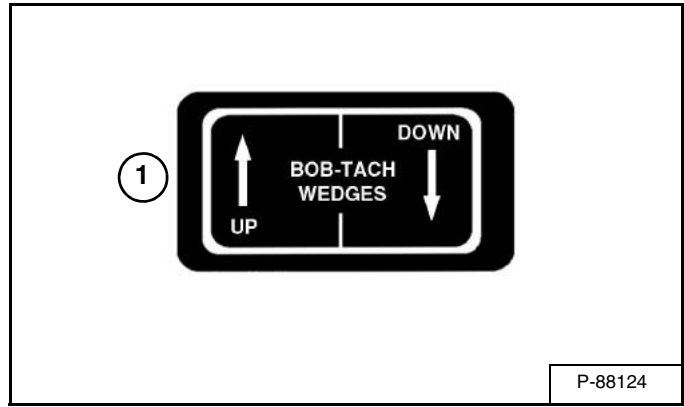
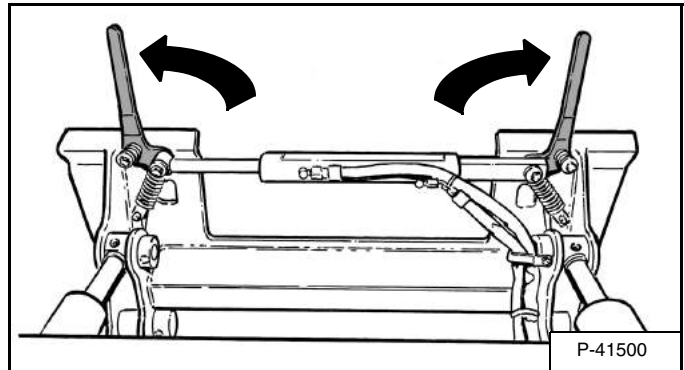
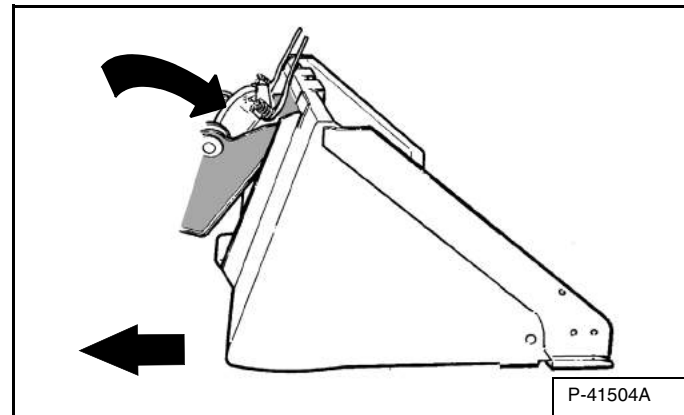

Figure 160



Push and hold the BOB-TACH "WEDGES UP" switch (Item 1) [Figure 159] until the levers are fully raised (wedges fully raised) [Figure 160].

Figure 161



Tilt the Bob-Tach forward and drive the work machine backward, away from the attachment [Figure 161].

NOTE: The Power Bob-Tach system has continuous pressurized hydraulic oil to keep the wedges in the engaged position and prevent attachment disengagement. Because the wedges can slowly lower, the operator may need to reactivate the switch (BOB-TACH "WEDGES UP") when removing an attachment to be sure both wedges are fully raised.

LIFTING THE ATTACHMENT

Procedure

NOTE: Use chains that are in good condition and of adequate size to lift the attachment.

Figure 162

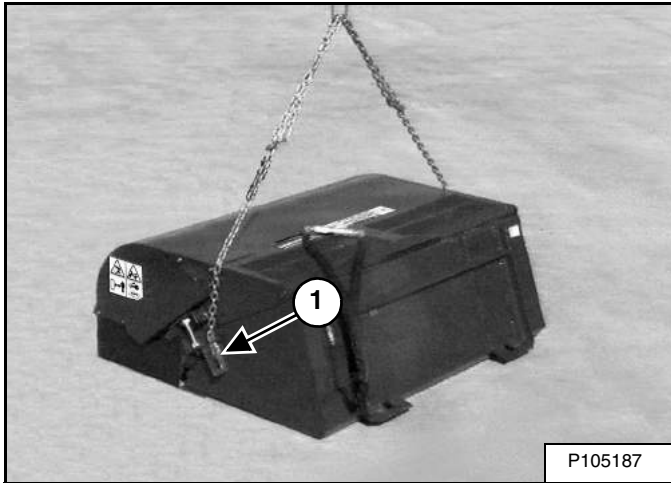

Connect the chains to the slot in the sweeper adjustment brackets on each of the sweeper (Item 1) [Figure 162].

Position the lifting chains in a location which will balance the sweeper while lifting.

TRANSPORTING THE ATTACHMENT ON A TRAILER

Fastening

NOTE: Use chains that are in good condition and of adequate size to secure the attachment.

Figure 163

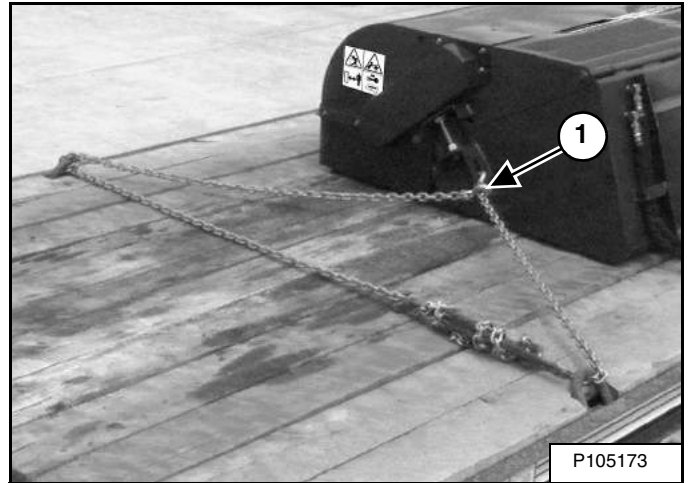

Connect the chains to the slot in the sweeper adjustment brackets on each end of the frame (Item 1) [Figure 163].

Use chain binders to prevent the attachment from moving during transport.

TRANSPORTING THE ATTACHMENT AND MACHINE ON A TRAILER

Loading And Fastening



AVOID SERIOUS INJURY OR DEATH

Adequately designed ramps of sufficient strength are needed to support the weight of the machine when loading onto a transport vehicle. Wood ramps can break and cause personal injury.

W-2058-0807

Be sure the transport and towing vehicles are of adequate size and capacity for weight of machine and attachment combination. (See machine and attachment Operation & Maintenance Manuals for specifications.)

Loading

The rear of the trailer must be blocked or supported when loading and unloading to prevent the front of the trailer from raising.

- Load the heaviest end of the machine and attachment combination first.
- Lower the attachment to the floor.
- Stop the engine.
- Engage the parking brake (if equipped).
- Exit the machine. (See the machine's Operation & Maintenance Manual for the correct procedure.)

Fastening

Install the chains at the front and rear tie down positions on the machine. (See the machine's Operation & Maintenance Manual to properly chain the machine to the transport vehicle.)

- Install chains on the attachment (if needed).
- Fasten each end of the chain to the transport vehicle.

NOTE: Use chain binders to prevent the attachment and machine from moving during transport.

PREVENTIVE MAINTENANCE

MAINTENANCE SAFETY	95
TROUBLESHOOTING	97
Chart	97
REGULAR MAINTENANCE	98
Drive Chain Adjustment	98
Adjusting The Stop Bolts	99
Adjusting The Gutter Brush	100
REMOVAL AND INSTALLATION OF BROOM	101
Procedure	101
REMOVAL AND INSTALLATION DRIVE CHAIN	107
Procedure	107
REMOVAL AND INSTALLATION GUTTER BRUSH BRISTLES	108
Procedure	108
ATTACHMENT STORAGE AND RETURN TO SERVICE	111
Storage	111
Return To Service	111



Bobcat®

MAINTENANCE SAFETY



WARNING







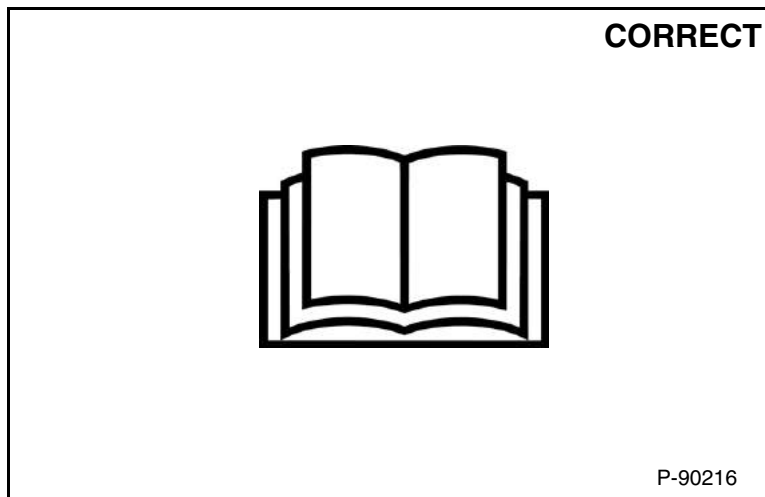

Instructions are necessary before operating or servicing machine. Read and understand the Operation & Maintenance Manual, Operator's Handbook and signs (decals) on machine. Follow warnings and instructions in the manuals when making repairs, adjustments or servicing. Check for correct function after adjustments, repairs or service. Untrained operators and failure to follow instructions can cause injury or death.

W-2003-0807



Safety Alert Symbol: This symbol with a warning statement, means: "Warning, be alert! Your safety is involved!" Carefully read the message that follows.



-  **Never service attachments / implements without instructions. See Operation & Maintenance Manual and Attachment / Implement Service Manual.**
-  **Cleaning and maintenance are required daily.**
-  **Never service or adjust attachment / implement with the engine running unless instructed to do so in manual.**
-  **Always lower the attachment / implement to the ground before lubricating or servicing.**
-  **Avoid contact with leaking hydraulic fluid or diesel fuel under pressure. It can penetrate skin or eyes.**
-  **Stop, cool and clean engine of flammable materials before checking fluids.**
-  **Keep body, loose objects and clothing away from moving parts, electrical contacts, hot parts and exhaust.**
-  **Safety glasses are needed for eye protection from electrical arcs, battery acid, compressed springs, fluids under pressure and flying debris or when tools are used. Use eye protection approved for type of welding.**

MSW30-0409



Bobcat®

TROUBLESHOOTING

Chart

 <b style="font-size: 24px; margin-left: 10px;">WARNING	<p>Instructions are necessary before operating or servicing machine. Read and understand the Operation & Maintenance Manual, Operator's Handbook and signs (decals) on machine. Follow warnings and instructions in the manuals when making repairs, adjustments or servicing. Check for correct function after adjustments, repairs or service. Untrained operators and failure to follow instructions can cause injury or death.</p> <p style="text-align: right; font-size: 10px;">W-2003-0807</p>
--	---

If the attachment is not working correctly, check the hydraulic system of the machine thoroughly before making any repairs on the attachment. attachment problems can be affected by a hydraulic system that is not operating to specifications. Connect a flow meter to the machine to check the hydraulic pump output, relief valve setting and tubelines to check flow and pressure. (See the machine's Service Manual for the correct procedure to connect the flow meter.)

Use the following troubleshooting chart to locate and correct problems which most often occur with the attachment.

PROBLEM	CAUSE	CORRECTION
Sweeper will not rotate.	Auxiliary front hydraulics not engaged.	Engage the machine's front auxiliary hydraulics. (See the machine's Operation & Maintenance Manual.)
	Auxiliary hydraulic switch not engaged.	Engage auxiliary hydraulic switch.
	Drive chain broken.	Repair or replace drive chain.
	Excessive hydraulic leakage.	Check hoses and hydraulic motor.
	No hydraulic flow.	Check hydraulic pump flow.
Sweeper bristles wear quickly.	Too much down pressure being applied to the broom.	Use the correct amount of down pressure needed for the conditions present.
Sweeper operation not effective.	Sweeper bristles worn.	Adjust bristle to cutting edge distance. Replace sweeper bristle sections.
	Sweeper rotating in wrong direction of machine travel.	Reverse sweeper rotation or the direction of machine travel.
Gutter Brush will not rotate.	Control valve for Gutter Brush not activated.	Move the valve spool to activate Gutter Brush.
Gutter Brush operation not effective.	Gutter Brush not making contact with surface.	Lower Gutter Brush to sweeping position.
	Gutter Brush rotating in wrong direction of machine travel.	Change direction of machine travel.

REGULAR MAINTENANCE

Drive Chain Adjustment

! WARNING

AVOID INJURY OR DEATH

Wear safety glasses to prevent eye injury when any of the following conditions exist:

- When fluids are under pressure.
- Flying debris or loose material is present.
- Engine is running.
- Tools are being used.

W-2019-0907

Figure 164

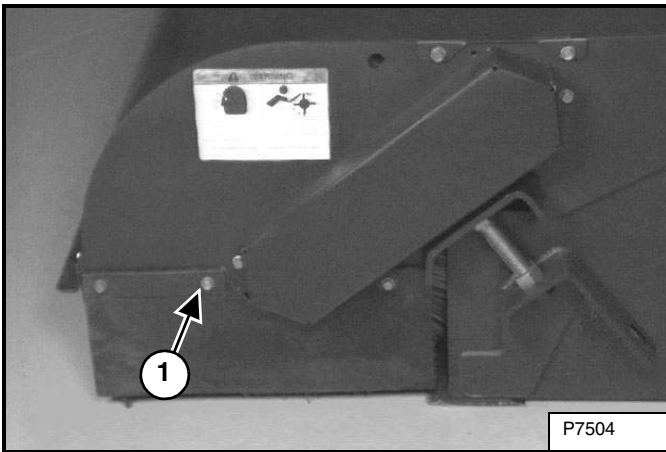

Remove the bolts (Item 1) [Figure 164] from the chain cover.

Remove the chain cover.

Figure 165

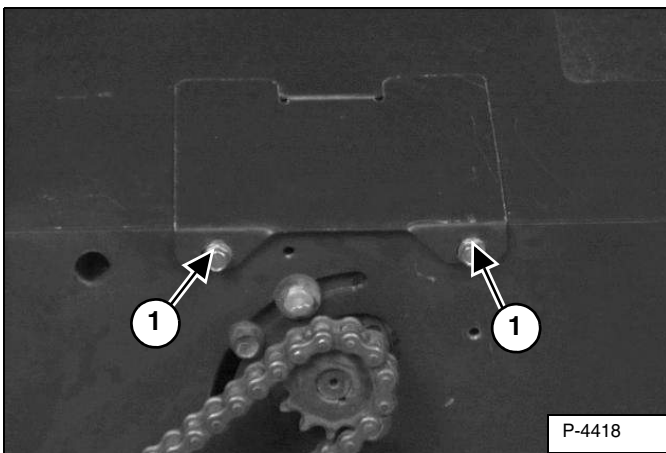

Remove the bolts (Item 1) [Figure 165] from the motor cover and remove the cover.

Figure 166

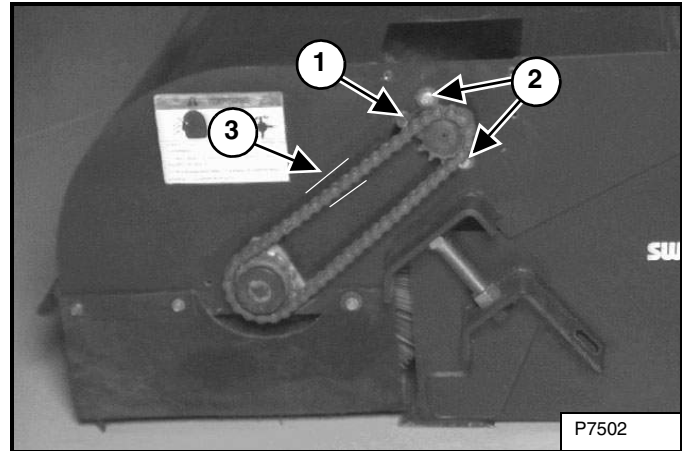

Loosen the motor bolts (Item 2) and the adjustment bolt (Item 1) [Figure 166]

Move the hydraulic motor until the drive chain (Item 3) [Figure 166] has 6 mm (0.25 in) deflection at the middle of the chain.

Tighten motor bolts (Item 2) and adjustment bolt (Item 1) [Figure 166].

Figure 167

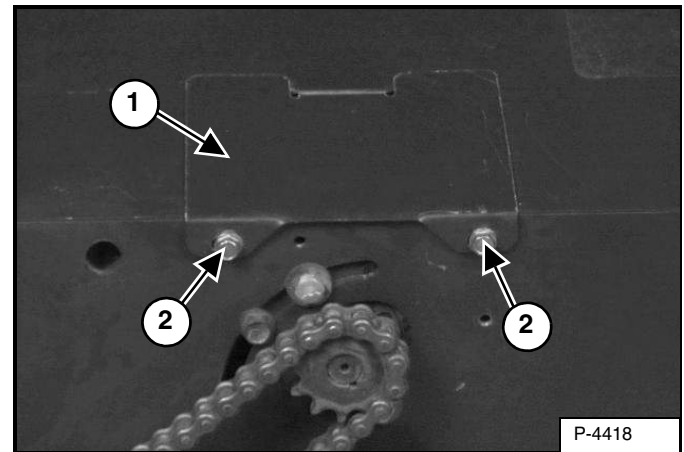

Install the motor cover (Item 1). Install and tighten the bolts (Item 2) [Figure 167]

REGULAR MAINTENANCE (CONT'D)

Drive Chain Adjustment (Cont'd)

Figure 168

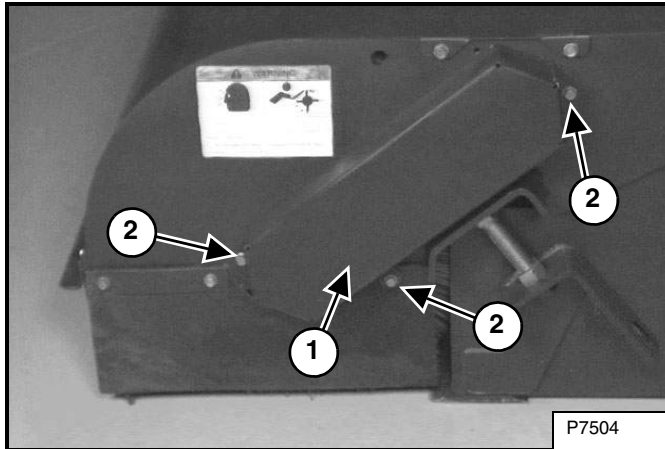

Install the chain cover (Item 1), install the bolts (Item 2) [Figure 168] and tighten.

! WARNING

AVOID INJURY OR DEATH

Never operate with covers or guards removed.

W-2121-0788

Adjusting The Stop Bolts

! WARNING

AVOID INJURY OR DEATH

Wear safety glasses to prevent eye injury when any of the following conditions exist:

- When fluids are under pressure.
- Flying debris or loose material is present.
- Engine is running.
- Tools are being used.

W-2019-0907

Raise the sweeper cutting edge above the ground level.

Figure 169

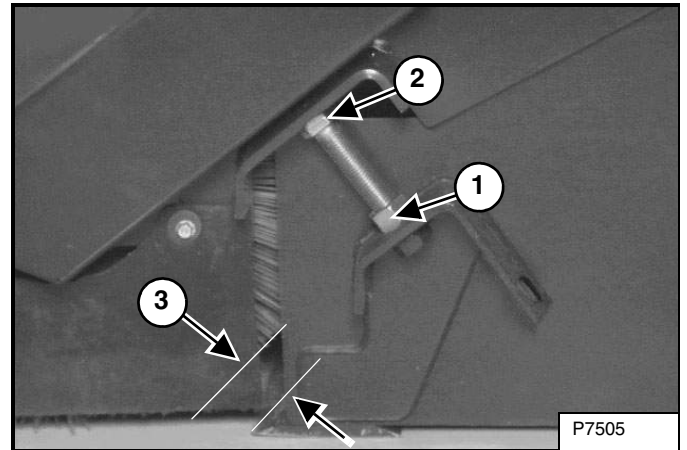

Loosen the lock nut (Item 1) on the adjustment bolt (Item 2) [Figure 169].

Turn the adjustment bolts (both sides) in or out until the broom bristles have a 24,5 - 51 mm (1 - 2 in) distance between bristles and cutting edge (Item 3) [Figure 169].

The bristles and cutting edge will wear, check adjustment regularly.

REGULAR MAINTENANCE (CONT'D)

Adjusting The Gutter Brush

As the brush wears, the brush will need to be lowered to keep the same angle.

Figure 170

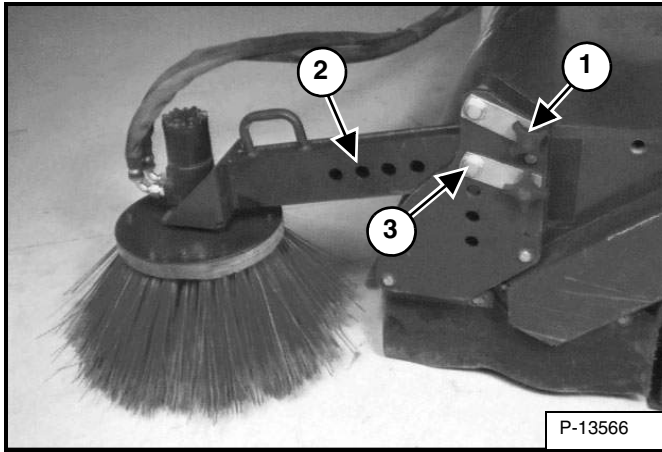

Remove the nut (Item 1) **[Figure 170]**.

Hold the pivot arm (Item 2) remove the pivot pin (Item 3) **[Figure 170]**.

Lower the arm to the next hole.

Install the pin, nut and tighten.

REMOVAL AND INSTALLATION OF BROOM

Procedure

Earlier Models



AVOID INJURY OR DEATH

Wear safety glasses to prevent eye injury when any of the following conditions exist:

- When fluids are under pressure.
- Flying debris or loose material is present.
- Engine is running.
- Tools are being used.

W-2019-0907

Remove the drive chain. (See REMOVAL AND INSTALLATION DRIVE CHAIN on Page 107.)

Figure 171

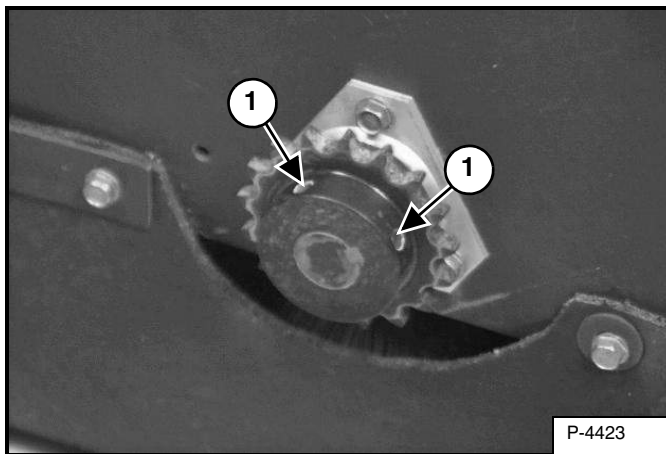

Remove the set screws (Item 1) [Figure 171] and remove the sprocket.

Figure 172

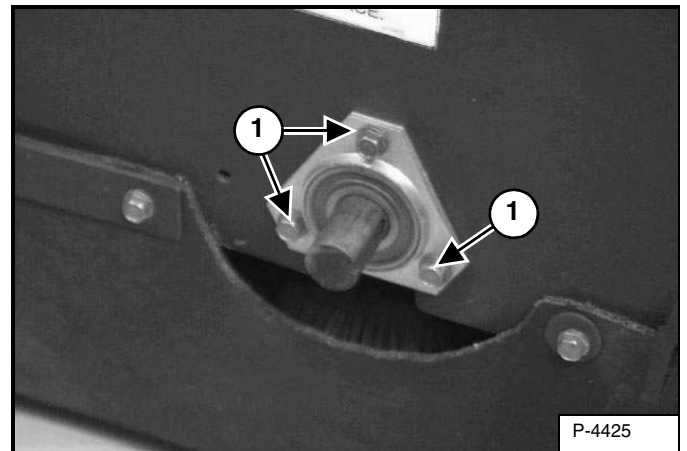

Remove the bolts (Item 1) [Figure 172] from the bearing mounting flange (both ends).

Figure 173

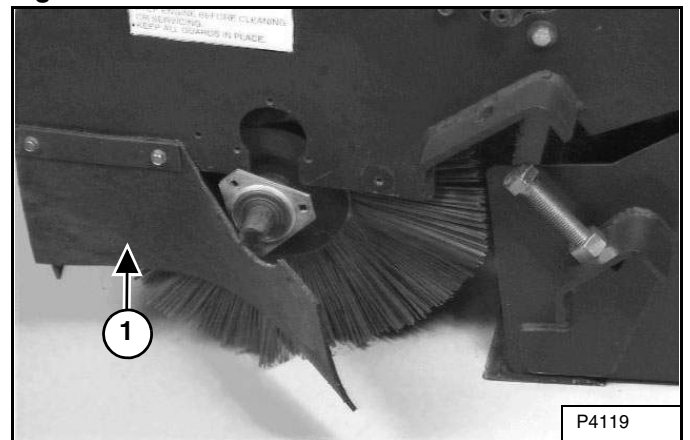

The rubber side cover (Item 1) [Figure 173] (both ends), can be loosened or removed if needed.

Use a proper chain hoist and lift the broom mounting frame [Figure 173].

Remove the broom.

REMOVAL AND INSTALLATION OF BROOM (CONT'D)

Procedure (Cont'd)

Earlier Models (Cont'd)

Figure 174



Make sure the hub plate is not damaged. Check to make sure the locking ring is tight [Figure 174].

Set the brush roller on end in a support.

Figure 175

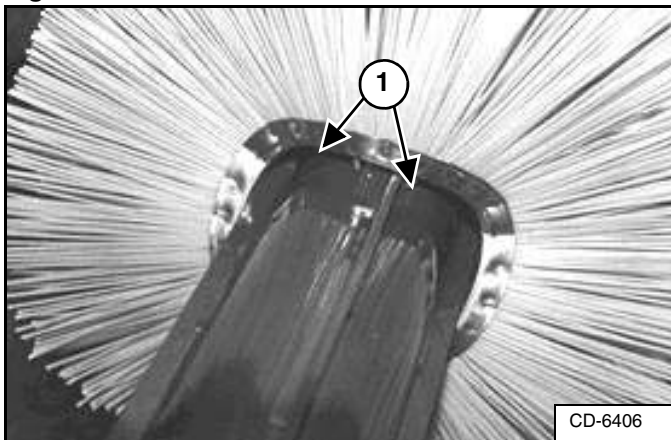

Install a bristle section so the locking tabs (Item 1) [Figure 175] straddle the bars on the rollers.

NOTE: Make sure that each time a bristle section is installed it is rotated 180° from the previous one.

NOTE: The locking tabs (Item 1) [Figure 175] are angled. Each bristle section must be installed so the tabs are angled toward the end with the two plates.

Figure 176

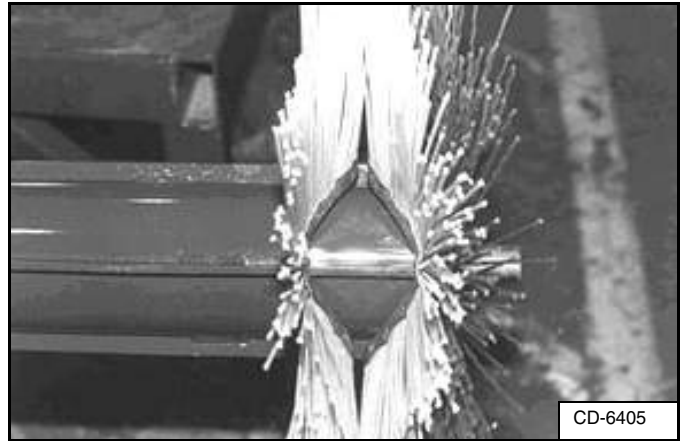

The pattern should be as shown [Figure 176].

Compress the bristle sections. Make sure the hub plate is tight against the inner tube and tighten the locking ring.

NOTE: Any time the bearings or locking collars are removed, the broom should be centered between the mounting frame during installation.

REMOVAL AND INSTALLATION OF BROOM (CONT'D)

Procedure (Cont'd)

Earlier Models (Cont'd)

Figure 177

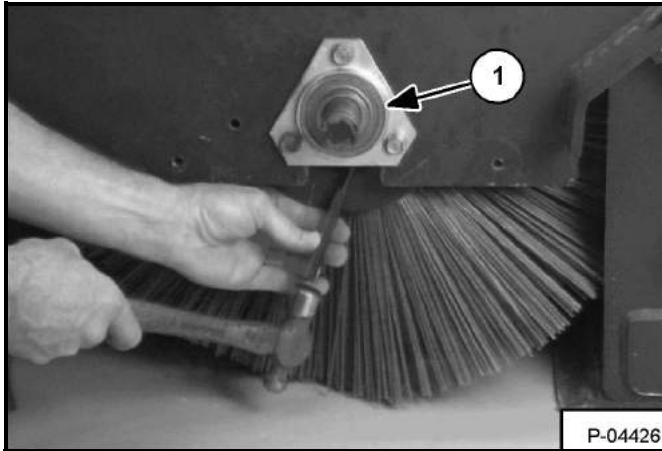

Install the broom in the mounting frame. Move the bearings, if needed to install the bearing mounting flange (Item 1) [Figure 177].

Use a punch and hammer, tap on the hole of the locking collar to tighten the collar [Figure 177].

Tighten the set screw on the locking collar.

Figure 178

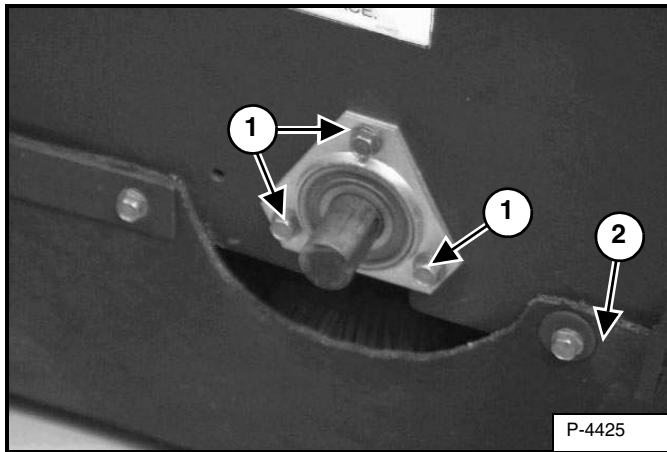

Install the bolts (Item 1) [Figure 178] onto the bearing mounting flange (both ends).

The rubber side cover (Item 2) [Figure 178] (both ends), can be tightened or installed if needed.

Figure 179

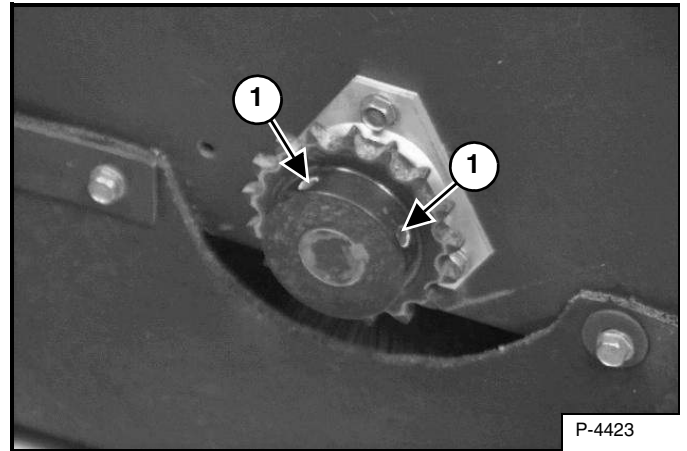

Install the sprocket. Install the set screws (Item 1) [Figure 179].

Install the chain. (See Procedure on Page 107.)

Adjust the chain. (See Drive Chain Adjustment on Page 98.)

REMOVAL AND INSTALLATION OF BROOM (CONT'D)

Procedure (Cont'd)

Later Models

Remove the drive chain. (See REMOVAL AND INSTALLATION DRIVE CHAIN on Page 107.)

Figure 180

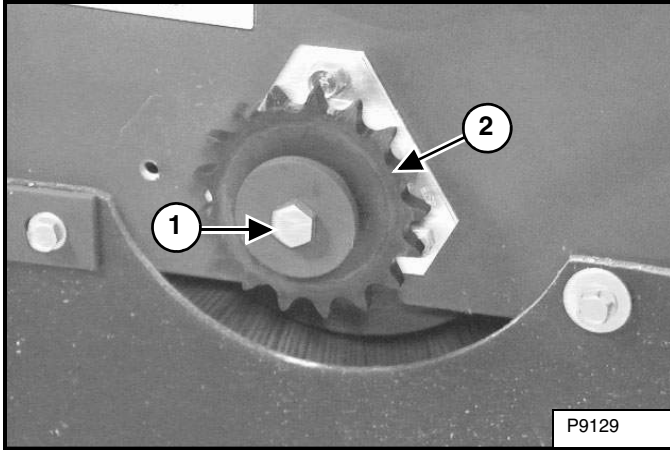

Remove the bolt (Item 1) [Figure 180] and washer from the end of the broom shaft.

Remove the sprocket (Item 2) [Figure 180].

Figure 181

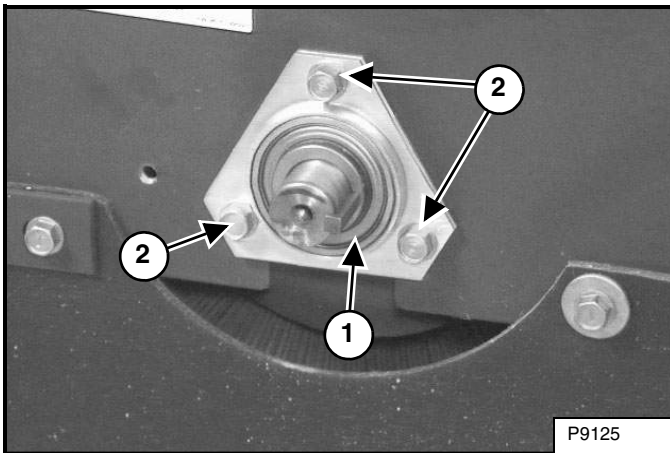

Remove the square key (Item 1) and the bolts (Item 2) [Figure 181] from the bearing mounting flange (both ends).

NOTE: The bearing mounting flanges will separate when the bolts are removed.

Figure 182

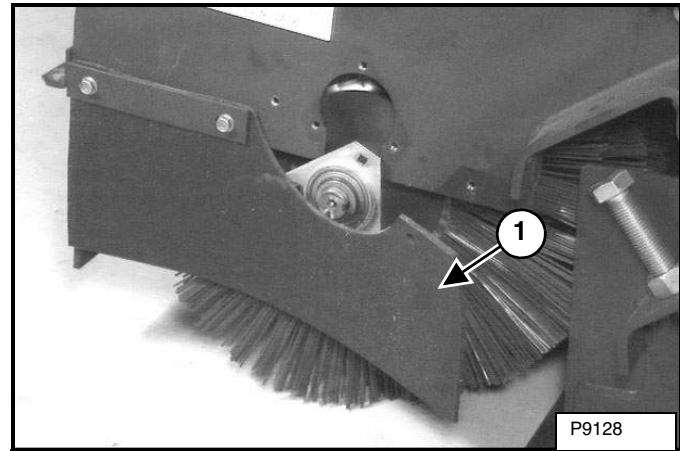

The rubber side cover (Item 1) [Figure 182] (both ends) can be loosened or removed if needed.

Use a proper chain hoist to lift the sweeper mounting frame and remove the broom.

Figure 183

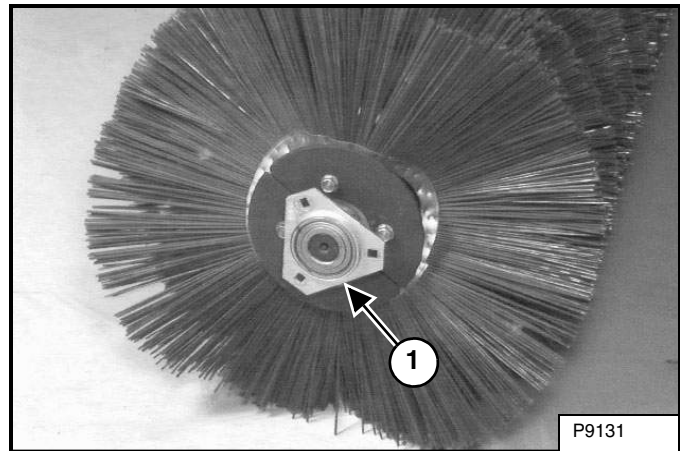

Remove the bearing and mounting flange (Item 1) [Figure 183] from the broom shaft (both ends).

REMOVAL AND INSTALLATION OF BROOM (CONT'D)

Procedure (Cont'd)

Later Models (Cont'd)

Figure 184

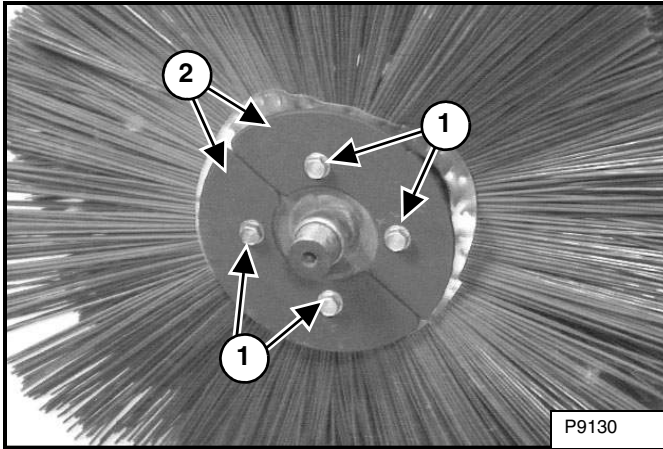

Remove the bolts (Item 1) to remove the plates (Item 2) [Figure 184].

The bristle sections can be removed from the broom shaft.

Figure 185

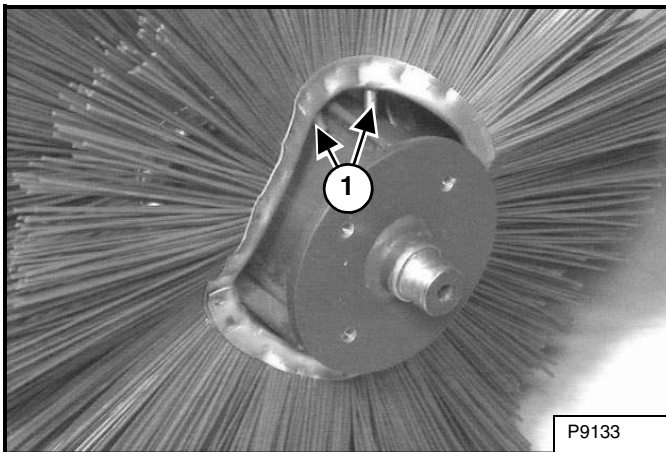

Install the bristle sections so the locking tabs (Item 1) [Figure 185] are located one on each side of the roller bars.

NOTE: The locking tabs (Item 1) [Figure 185] are angled. Each bristle section must be installed so the tabs are angled toward the end with the two plates.

Figure 186

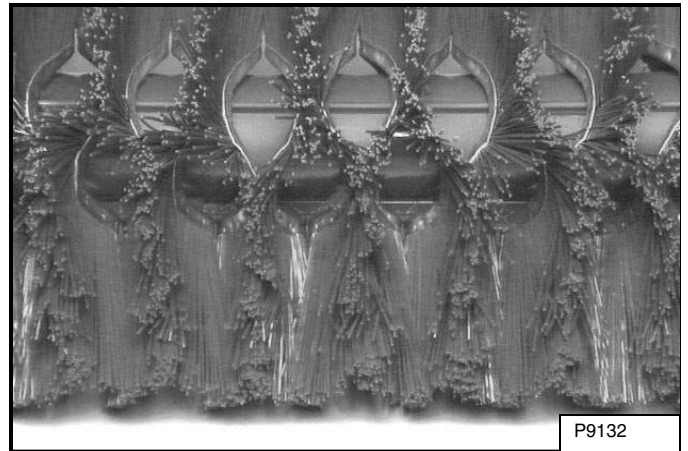

Install the bristle sections to form a pattern as shown [Figure 186].

Figure 187

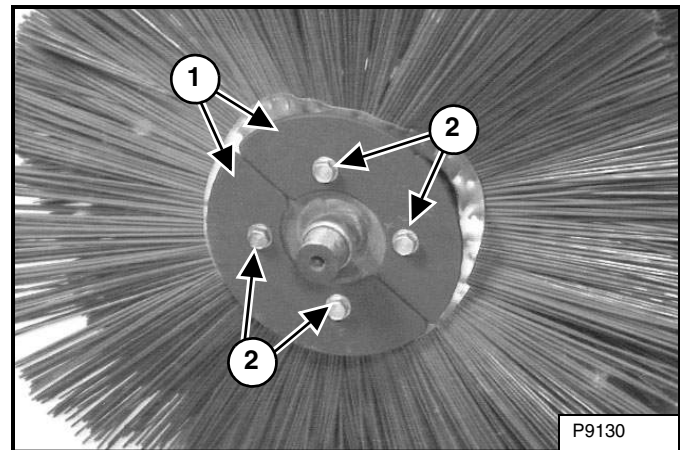

Install the plates (Item 1). Install and tighten the bolts (Item 2) [Figure 187].

Lower the sweeper mounting frame on to the broom.

REMOVAL AND INSTALLATION OF BROOM (CONT'D)

Procedure (Cont'd)

Later Models (Cont'd)

Figure 188

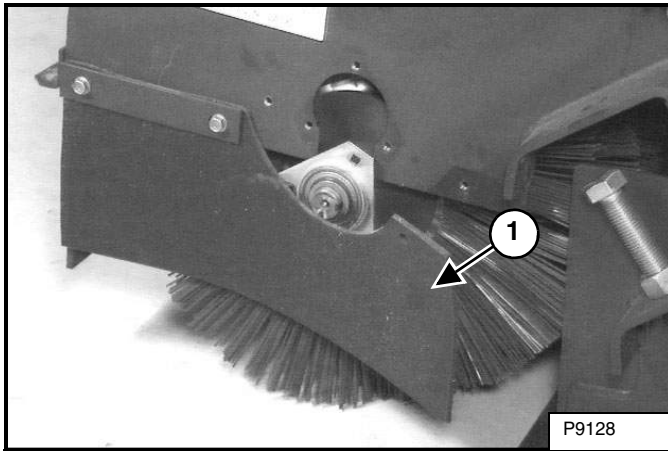

Install the rubber side cover (Item 1) [Figure 188] (both ends). (If loosened.)

Figure 189

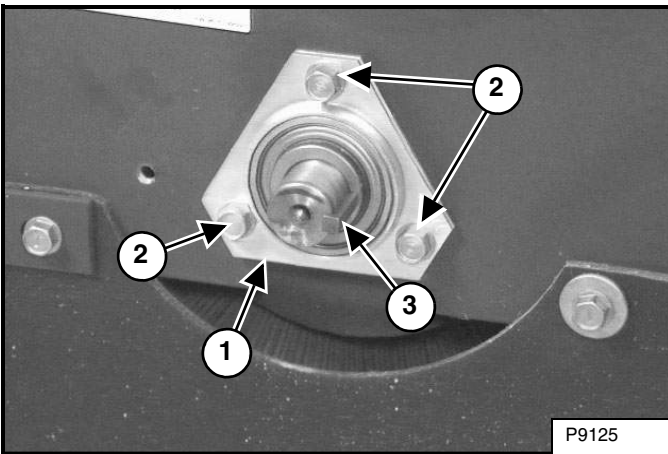

Install the bearing (Item 1). Install and tighten the bolts and nuts (Item 2). Install the square key (Item 3) [Figure 189].

NOTE: The bearing flange must face outward during installation for sprocket clearance.

Figure 190

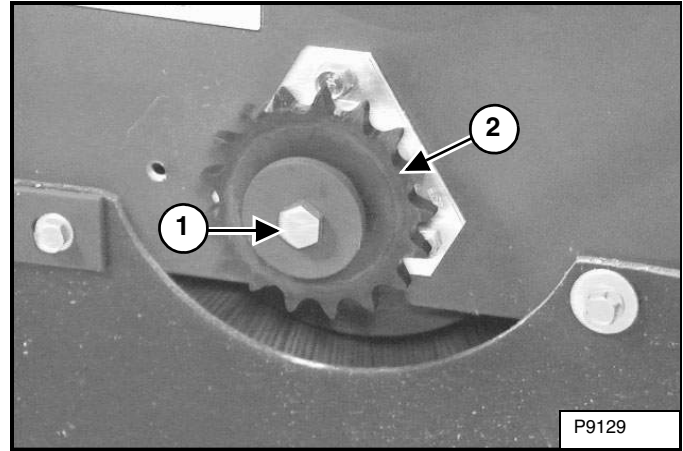

Install the sprocket (Item 2) [Figure 190].

Install the bolt (Item 1) [Figure 190] and washer on to the end of the broom shaft.

Adjust the chain. (See Drive Chain Adjustment on Page 98.)

Install the drive chain. (See REMOVAL AND INSTALLATION DRIVE CHAIN on Page 107.)

REMOVAL AND INSTALLATION DRIVE CHAIN

Procedure

Figure 191

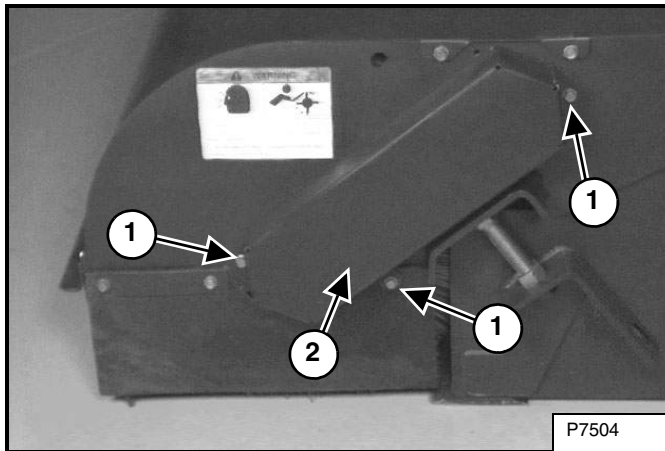

Remove the bolts (Item 1) [Figure 191] from the chain cover.

Remove the chain cover (Item 2) [Figure 191].

Figure 192

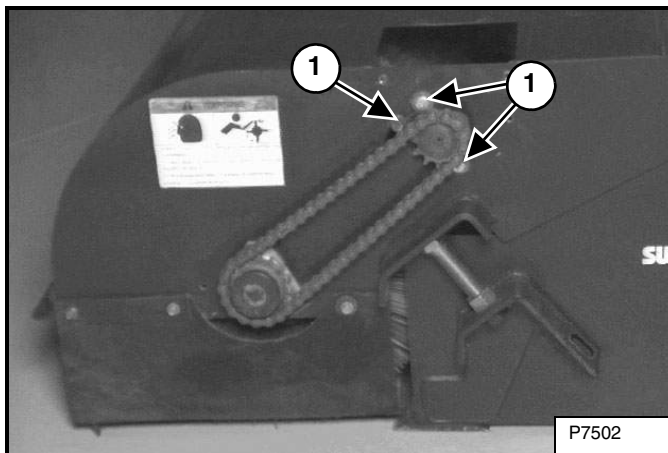

Loosen the bolts (Items 1) [Figure 192] on the hydraulic motor.

Move the hydraulic motor to loosen the chain.

Figure 193

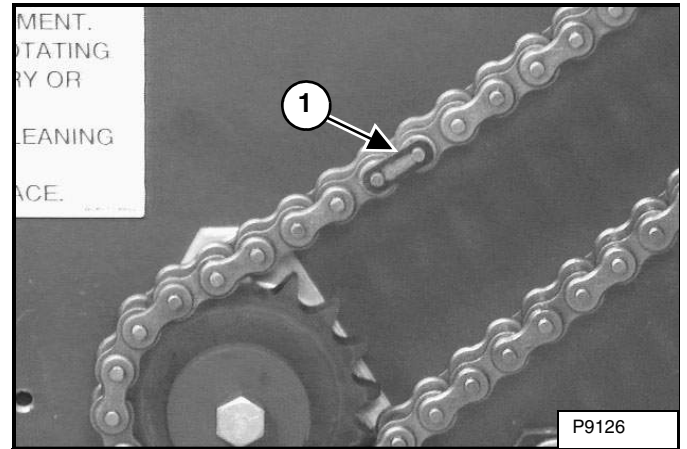

Remove the chain connector link (Item 1) [Figure 193] and remove the chain.

Install the chain and connector link (Item 1) [Figure 193].

Adjust the drive chain. (See Drive Chain Adjustment on Page 98.)

Figure 194

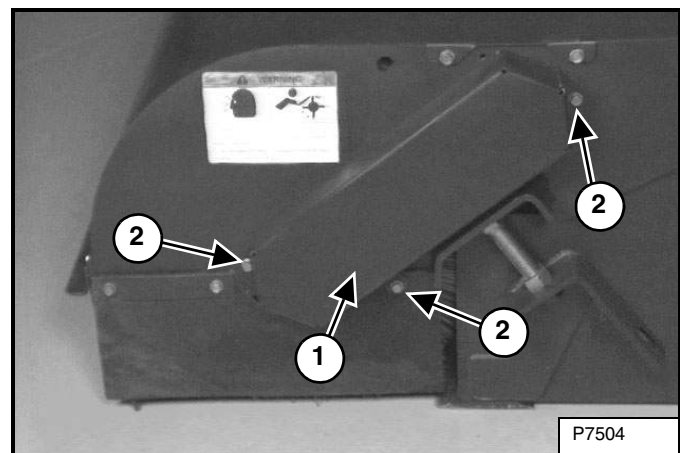

Install the chain cover (Item 1) [Figure 194].

Install the bolts (Item 2) [Figure 194] from the chain cover.

! WARNING

AVOID INJURY OR DEATH
Never operate with covers or guards removed.

W-2121-0788

REMOVAL AND INSTALLATION GUTTER BRUSH BRISTLES

Procedure

Figure 195

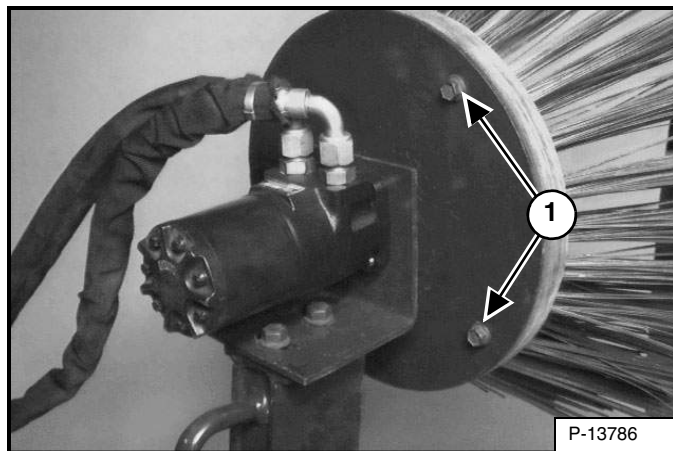

Remove the four mounting bolts (Item 1) [Figure 195] and remove the bristle assembly.

Installation: Install the bristle assembly. Tighten the four mounting bolts (Item 1) to 34 - 38 N•m (25 - 28 ft-lb) torque.

REMOVAL AND INSTALLATION GUTTER BRUSH BRISTLES (CONT'D)

Procedure (Cont'd)

Figure 196

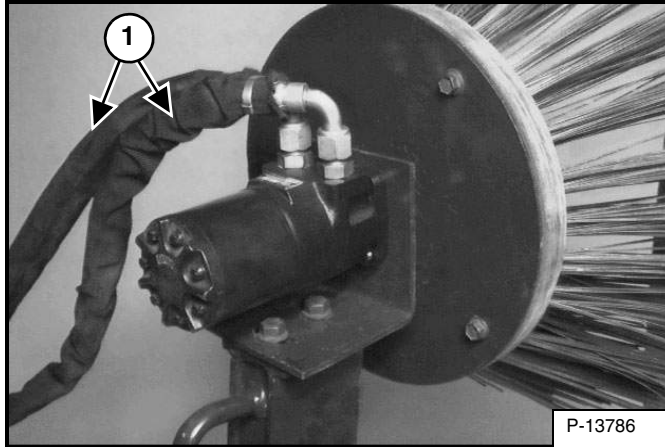

Remove the hydraulic hoses (Item 1) [Figure 196].

Installation: Tighten the hose fittings to 81 N•m (60 ft-lb) torque.

IMPORTANT

When repairing hydrostatic and hydraulic systems, clean the work area before disassembly and keep all parts clean. Always use caps and plugs on hoses, tubelines and ports to keep dirt out. Dirt can quickly damage the system.

I-2003-0888

Figure 197

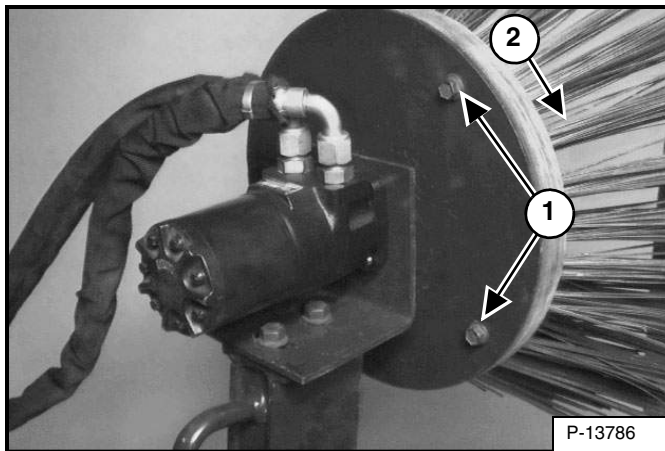

Remove the four mounting bolts (Item 1) and remove the bristle assembly (Item 2) [Figure 197].

Installation: Install the bristle assembly (Item 2). Install and tighten the four mounting bolts (Item 1) [Figure 197] to 34 - 38 N•m (25 - 28 ft-lb) torque.

Figure 198

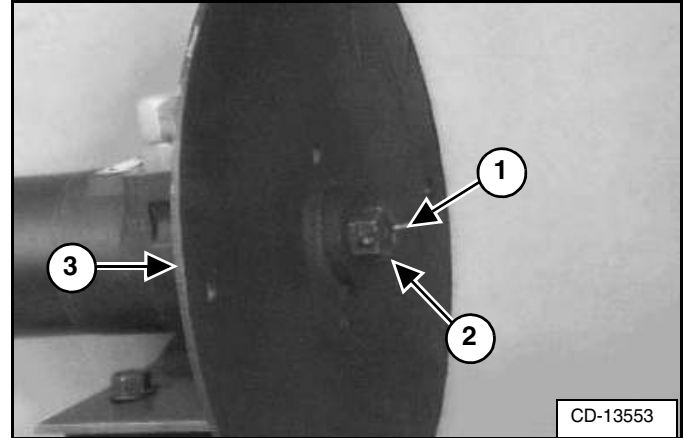

Remove the cotter pin (Item 1) [Figure 198].

Remove the castle nut (Item 2) [Figure 198] from the motor shaft.

Remove the brush mounting plate (Item 3) [Figure 198].

Installation: Install the brush mounting plate (Item 3). Install and tighten the castle nut (Item 2) to 217 - 312 N•m (200 - 230 ft-lb) torque. Install the cotter pin (Item 1) [Figure 198].

REMOVAL AND INSTALLATION GUTTER BRUSH BRISTLES (CONT'D)

Procedure (Cont'd)

Figure 199

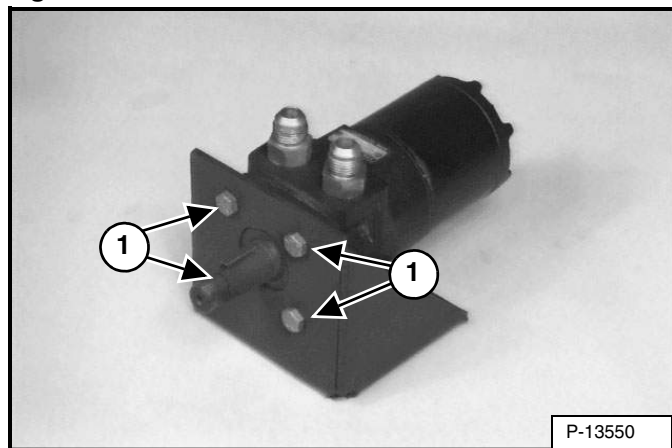

Remove the four hydraulic motor mounting bolts (Item 1) [Figure 199].

Installation: Tighten the four mounting bolts to 34 - 38 N•m (25 - 28 ft-lb) torque.

NOTE: Refer to the attachment Service Manual for the hydraulic motor disassembly, assembly and repair procedures.

ATTACHMENT STORAGE AND RETURN TO SERVICE

Storage

Sometimes it may be necessary to store your Bobcat attachment for an extended period of time. Below is a list of items to perform before storage.

- Thoroughly clean the attachment.
- Lubricate the attachment.
- Inspect the Bob-Tach wedge mounts, mounting flange and all welds on the attachment for wear and damage.
- Check for loose hardware, missing guards, or damaged parts.
- Replace worn or damaged parts.
- Check for damaged or missing decals. Replace if necessary.
- Place the attachment in a dry protected shelter.
- Place the attachment flat on the ground.

NOTE: In muddy conditions or to prevent the attachment from freezing to the ground, put the attachment on planks or blocks before removing the attachment from the machine.

Return To Service

After the Bobcat attachment has been in storage, it is necessary to follow a list of items to return the attachment to service.

- Be sure all shields and guards are in place.
- Lubricate the attachment.
- Install and operate attachment, check for correct function.
- Check for leaks. Repair as needed.



Bobcat®

MACHINE SIGN TRANSLATIONS

MACHINE SIGN TRANSLATIONS	115
Warning (6708822)	115
Warning (7127607)	116
Warning (7141748)	117



Bobcat®

Warning (6708822)

 WARNING	
	
FLYING OBJECTS AND ROTATING PARTS CAN CAUSE INJURY OR DEATH	
<ul style="list-style-type: none">• STAY AT LEAST 10 FEET (3M) AWAY FROM OPERATING EQUIPMENT.• STOP ENGINE BEFORE CLEANING OR SERVICING.• KEEP ALL GUARDS IN PLACE.	
<small>72080 SW 6708822D enUS</small>	

 ADVERTENCIA	
	
LOS OBJETOS VOLATILES Y LAS PIEZAS GIRATORIAS PUEDEN PROVOCAR HERIDAS GRAVES O LA MUERTE	
<ul style="list-style-type: none">• MANTÉNGASE A UNA DISTANCIA MÍNIMA DE 10 PIES (3 M) DE LOS EQUIPOS QUE SE ENCUENTREN EN FUNCIONAMIENTO• DETENGA EL MOTOR ANTES DE EFECTUAR LA LIMPIEZA O EL SERVICIO DE MANTENIMIENTO.• MANTENGA TODOS LOS DISPOSITIVOS DE PROTECCIÓN EN SU LUGAR.	
<small>72080 SW 6708822D esAR</small>	

 AVERTISSEMENT	
	
LES OBJETS PROJÉTÉS ET LES PIÈCES EN ROTATION PEUVENT ENTRAÎNER DES BLESSURES GRAVES, VOIRE MORTELLES	
<ul style="list-style-type: none">• RESTEZ À UNE DISTANCE MINIMALE DE 3 m (10 pi) DE L'ÉQUIPEMENT EN MARCHÉ.• ARRÊTEZ LE MOTEUR AVANT DE FAIRE DU NETTOYAGE OU DE L'ENTRETIEN.• GARDEZ TOUS LES PROTECTEURS EN PLACE.	
<small>72080 SW 6708822D frCA</small>	

MACHINE SIGN TRANSLATIONS (CONT'D)

Warning (7127607)

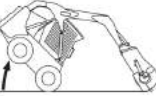

⚠ WARNING

AVOID INJURY OR DEATH

* LIFT RESTRICTION - WHILE DUMPING A LOADED SWEEPER, THE LOWEST PART OF THE SWEEPER SHOULD NOT EXCEED 1 FT. (0,3 m) FROM THE GROUND. TIPPING CAN RESULT.

LOWER SWEEPER TO GROUND AND STOP ENGINE BEFORE CLEANING, SERVICING OR REPAIRING.

58976 SW 7127607 04/18

***LIFT RESTRICTION**



1 FT.
(0,3 m)

APPROVED AND NON-APPROVED LOADER-SWEEPER COMBINATION

SWEEPER MODEL	APPROVED				NON-APPROVED			
	LOADER RATED OPERATING CAPACITY							
	950 LBS (432 kg)	1100 LBS (500 kg)	1250 LBS (568 kg)	1500 LBS (680 kg)	1750 LBS (794 kg)	1900 LBS (864 kg)	2200 LBS (1000 kg)	2500 LBS (1140 kg)
54 INCH	*LIFT RESTRICTION							
60 INCH			*LIFT RESTRICTION	*LIFT RESTRICTION				
72 INCH				*LIFT RESTRICTION	*LIFT RESTRICTION			
84 INCH							*LIFT RESTRICTION	



⚠ ADVERTENCIA

EVITE LESIONES O LA MUERTE

* LIMITACIÓN DE LA ELEVACIÓN: AL VACIAR LA CARGA DE LA BARREDORA, LA DISTANCIA ENTRE EL SUELO Y LA PARTE MÁS BAJA DE LA BARREDORA NO DEBE SER SUPERIOR A 1 PIE (0,3 m). EN CASO DE NO CUMPLIRSE ESTA CONDICIÓN, LA MÁQUINA PUEDE VOLCAR.

BAJE LA BARREDORA HASTA EL NIVEL DEL SUELO Y DETENGA EL MOTOR ANTES DE REALIZAR SU LIMPIEZA, SERVICIO DE MANTENIMIENTO O REPARACIÓN.

58976 SW 7127607 04/18

***LIMITACIÓN DE LA ELEVACIÓN**



1 PIE
(0,3 m)

COMBINACIÓN CARGADORA-BARREDORA APROBADA Y NO APROBADA

MODELO DE BARREDORA	APROBADA				NO APROBADA			
	CAPACIDAD MÁXIMA DE OPERACIÓN DE LA CARGADORA							
	950 LB (432 kg)	1100 LB (500 kg)	1250 LB (568 kg)	1500 LB (680 kg)	1750 LB (794 kg)	1900 LB (864 kg)	2200 LB (1000 kg)	2500 LB (1140 kg)
54 PULGADAS	*LIMITACIÓN DE LA ELEVACIÓN							
60 PULGADAS			*LIMITACIÓN DE LA ELEVACIÓN	*LIMITACIÓN DE LA ELEVACIÓN				
72 PULGADAS				*LIMITACIÓN DE LA ELEVACIÓN	*LIMITACIÓN DE LA ELEVACIÓN			
84 PULGADAS							*LIMITACIÓN DE LA ELEVACIÓN	

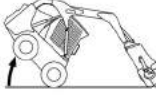

⚠ AVERTISSEMENT

RISQUE DE BLESSURE OU DE MORT

* RESTRICTION DE LEVAGE - LORS DU BASCULEMENT DE LA BALAYEUSE POUR LA VIDER, SA PARTIE LA PLUS BASSE NE DOIT PAS ÊTRE À PLUS DE 30 cm [1 pi] DU SOL. RISQUE DE RENVERSEMENT.

BAISSEZ LA BALAYEUSE SUR LE SOL ET ARRÊTEZ LE MOTEUR AVANT DE FAIRE TOUT NETTOYAGE, ENTRETIEN OU RÉPARATION.

58976 SW 7127607 04/18

***RESTRICTION DE LEVAGE**



1 PI
(0,3 m)

COMBINAISON DE CHARGEUSE-BALAYEUSE APPROUVÉE ET NON APPROUVÉE

MODELE DE BALAYEUSE	APPROUVÉE				NON APPROUVÉE			
	CAPACITÉ NOMINALE DE LA CHARGEUSE							
	950 lb (432 kg)	1 100 lb (500 kg)	1 250 lb (568 kg)	1 500 lb (680 kg)	1 750 lb (794 kg)	1 900 lb (864 kg)	2 200 lb (1 000 kg)	2 500 lb (1 140 kg)
54 po (132 cm)	*RESTRICTION DE LEVAGE							
60 po (152 cm)			RESTRICTION DE LEVAGE	RESTRICTION DE LEVAGE				
72 po (182 cm)				RESTRICTION DE LEVAGE	RESTRICTION DE LEVAGE			
84 po (212 cm)							RESTRICTION DE LEVAGE	

MACHINE SIGN TRANSLATIONS (CONT'D)

Warning (7141748)

★

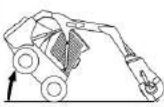

⚠ WARNING

AVOID INJURY OR DEATH

* LIFT RESTRICTION - WHILE DUMPING A LOADED SWEEPER, THE LOWEST PART OF THE SWEEPER SHOULD NOT EXCEED 1 FT. [0,3 m] FROM THE GROUND. TIPPING CAN RESULT. LOWER SWEEPER TO GROUND AND STOP ENGINE BEFORE CLEANING, SERVICING OR REPAIRING.

6800 09 7141748 001
© 2010 DEERE & CO. ALL RIGHTS RESERVED

*LIFT RESTRICTION

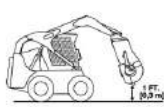

APPROVED AND NON-APPROVED LOADER-SWEEPER COMBINATION

SWEEPER MODEL	APPROVED				NON-APPROVED		
	LOADER RATED OPERATING CAPACITY						
	500 LBS (227 kg)	550 LBS (249 kg)	700 LBS (318 kg)	850 LBS (386 kg)	950 LBS (432 kg)	1100 LBS (500 kg)	1250 LBS (568 kg)
36 INCH	*LIFT RESTRICTION	*LIFT RESTRICTION	*LIFT RESTRICTION				
44 INCH		*LIFT RESTRICTION	*LIFT RESTRICTION	*LIFT RESTRICTION			
48 INCH			*LIFT RESTRICTION	*LIFT RESTRICTION			
54 INCH				*LIFT RESTRICTION	*LIFT RESTRICTION		

★



⚠ ADVERTENCIA

EVITE LESIONES O LA MUERTE

*RESTRICCIONES DE ELEVACIÓN - MIENTRAS VACÍA UNA BARREDORA CARGADA, LA PARTE MÁS BAJA DE LA BARREDORA NO DEBE EXCEDER LA ALTURA DE 1 PIE (0,3 m) DEL PISO. PUEDEN OCURRIR TRASTORNOS. BAJE LA BARREDORA HASTA EL PISO Y DETENGA EL MOTOR ANTES DE LIMPIAR, REALIZAR EL SERVICIO DE MANTENIMIENTO O DE REPARAR.

6800 09 7141748 001
© 2010 DEERE & CO. ALL RIGHTS RESERVED

*RESTRICCIONES DE ELEVACIÓN



COMBINACIÓN BARREDORA-CARGADORA APROBADA Y NO APROBADA

MODELO DE BARREDORA	APROBADA				NO APROBADA		
	CAPACIDAD DE OPERACIÓN CLASIFICADA DE LA PALA MECÁNICA						
	500 LIBRAS (227 kg)	550 LIBRAS (249 kg)	700 LIBRAS (318 kg)	850 LIBRAS (386 kg)	950 LIBRAS (432 kg)	1100 LIBRAS (500 kg)	1250 LIBRAS (568 kg)
36 PULGADAS	*RESTRICCIONES DE ELEVACIÓN	*RESTRICCIONES DE ELEVACIÓN	*RESTRICCIONES DE ELEVACIÓN				
44 PULGADAS		*RESTRICCIONES DE ELEVACIÓN	*RESTRICCIONES DE ELEVACIÓN	*RESTRICCIONES DE ELEVACIÓN			
48 PULGADAS			*RESTRICCIONES DE ELEVACIÓN	*RESTRICCIONES DE ELEVACIÓN			
54 PULGADAS				*RESTRICCIONES DE ELEVACIÓN	*RESTRICCIONES DE ELEVACIÓN		

★



⚠ AVERTISSEMENT

RISQUE DE BLESSURE OU DE MORT

* RESTRICTION DE LEVAGE - LORS DU BASCULAGE DE LA BALAYEUSE POUR LA VIDER, SA PARTIE LA PLUS BASSE NE DOIT PAS ÊTRE À PLUS DE 30 cm [1 pi] DU SOL. LA CHARGEUSE POURRAIT BASCULER. BAISSÉZ LA BALAYEUSE SUR LE SOL ET ARRÊTEZ LE MOTEUR AVANT DE FAIRE TOUT NETTOYAGE, ENTRETIEN OU RÉPARATION.

6800 09 7141748 001
© 2010 DEERE & CO. ALL RIGHTS RESERVED

*RESTRICTION DE LEVAGE



COMBINAISON DE CHARGEUSE-BALAYEUSE APPROUVÉE ET NON APPROUVÉE

MODELE DE BALAYEUSE	APPROUVÉE				NON APPROUVÉE		
	CAPACITÉ NOMINALE DE LA CHARGEUSE						
	500 lb (227 kg)	550 lb (249 kg)	700 lb (318 kg)	850 lb (386 kg)	950 lb (432 kg)	1100 lb (500 kg)	1250 lb (568 kg)
36 po (91 cm)	*RESTRICTION DE LEVAGE	*RESTRICTION DE LEVAGE	*RESTRICTION DE LEVAGE				
44 po (112 cm)		*RESTRICTION DE LEVAGE	*RESTRICTION DE LEVAGE	*RESTRICTION DE LEVAGE			
48 po (122 cm)			*RESTRICTION DE LEVAGE	*RESTRICTION DE LEVAGE			
54 po (137 cm)				*RESTRICTION DE LEVAGE	*RESTRICTION DE LEVAGE		



Bobcat®

SPECIFICATIONS

SWEEPER SPECIFICATIONS	121
Dimensions	121
Performance	121
Hydraulic System	122
Capacities	122
SWEEPER WITH OPTIONAL GUTTER BRUSH SPECIFICATIONS	123
Dimensions	123
Performance	123
Hydraulic System	124
Capacities	124

Certain specification(s) are based on engineering calculations and are not actual measurements. Specification(s) are provided for comparison purposes only and are subject to change without notice. Specification(s) for your individual Bobcat equipment will vary based on normal variations in design, manufacturing, operating conditions and other factors.



Bobcat®

SWEeper SPECIFICATIONS

Dimensions

- Where applicable, specifications conform to **SAE and ISO** standards and are subject to change without notice.

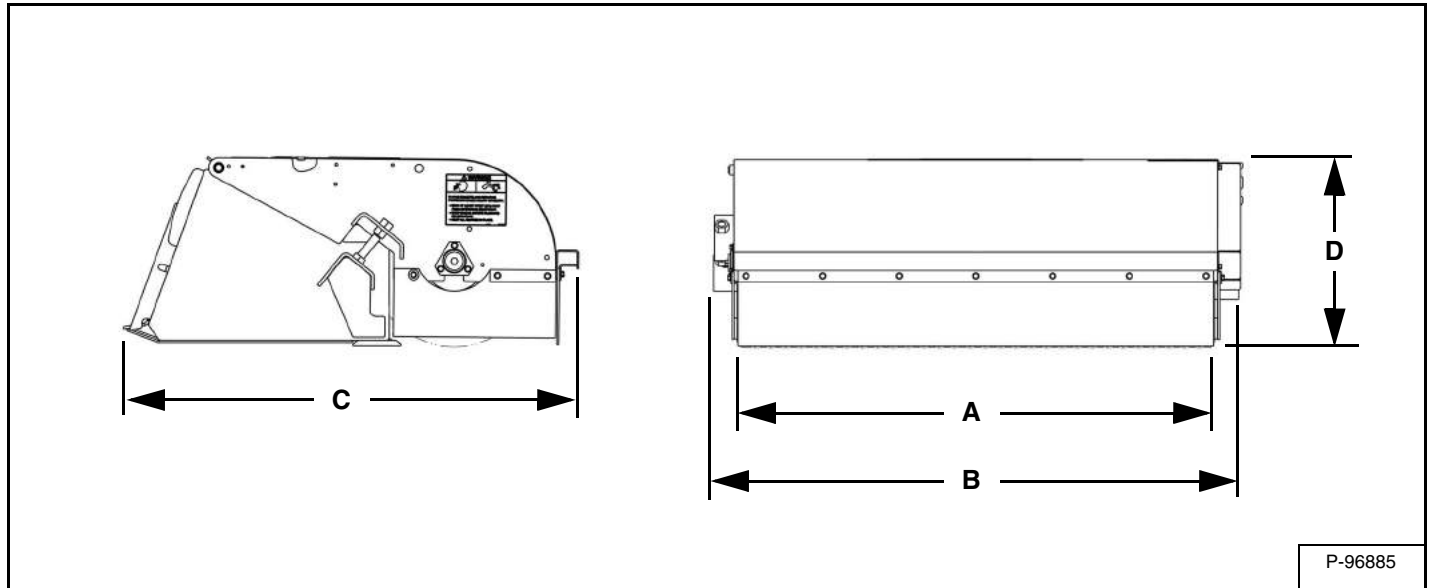

	54 SWEEPER	60 SWEEPER	72 SWEEPER
Sweeping Width (A)	1372 mm (54 in)	1524 mm (60 in)	1829 mm (72 in)
Overall Width (B)	1529 mm (60.2 in)	1681 mm (66.2 in)	1986 mm (78.2 in)
Overall Length (C)	1414 mm (55.7 in)	1414 mm (55.7 in)	1414 mm (55.7 in)
Overall Height (D)	594 mm (23.4 in)	594 mm (23.4 in)	594 mm (23.4 in)

Performance

	54 SWEEPER	60 SWEEPER	72 SWEEPER
Weight	316 kg (696 lb)	344 kg (758 lb)	384 kg (845 lb)
Brush Diameter	544 mm (21.4 in)	544 mm (21.4 in)	544 mm (21.4 in)
Bristle Material	Replaceable Polypropylene Sections	Replaceable Polypropylene Sections	Replaceable Polypropylene Sections
No. of Bristle Sections	27	30	36
Chain / Sprocket Reduction	1.42	1.42	1.42
Chain Size	#60 HS	#60 HS	#60 HS
Broom rpm @ 37,9 L/min (10 U.S. gpm)	145 rpm	145 rpm	145 rpm

SWEEPER SPECIFICATIONS (CONT'D)

Hydraulic System

	54 SWEEPER	60 SWEEPER	72 SWEEPER
Hydraulic Motor Displacement	195 cm ³ (11.9 in ³)	195 cm ³ (11.9 in ³)	195 cm ³ (11.9 in ³)
Max Allowable Continuous Hydraulic Flow	37,9 L/min (10 gpm)	113,6 L/min (30 gpm)	113,6 L/min (30 gpm)

Capacities

	54 SWEEPER	60 SWEEPER	72 SWEEPER
Bucket Capacity	0,30 m ³ (10.8 ft ³)	0,34 m ³ (12.0 ft ³)	0,4 m ³ (14.4 ft ³)

SWEeper WITH OPTIONAL GUTTER BRUSH SPECIFICATIONS

Dimensions

- Where applicable, specifications conform to **SAE and ISO** standards and are subject to change without notice.

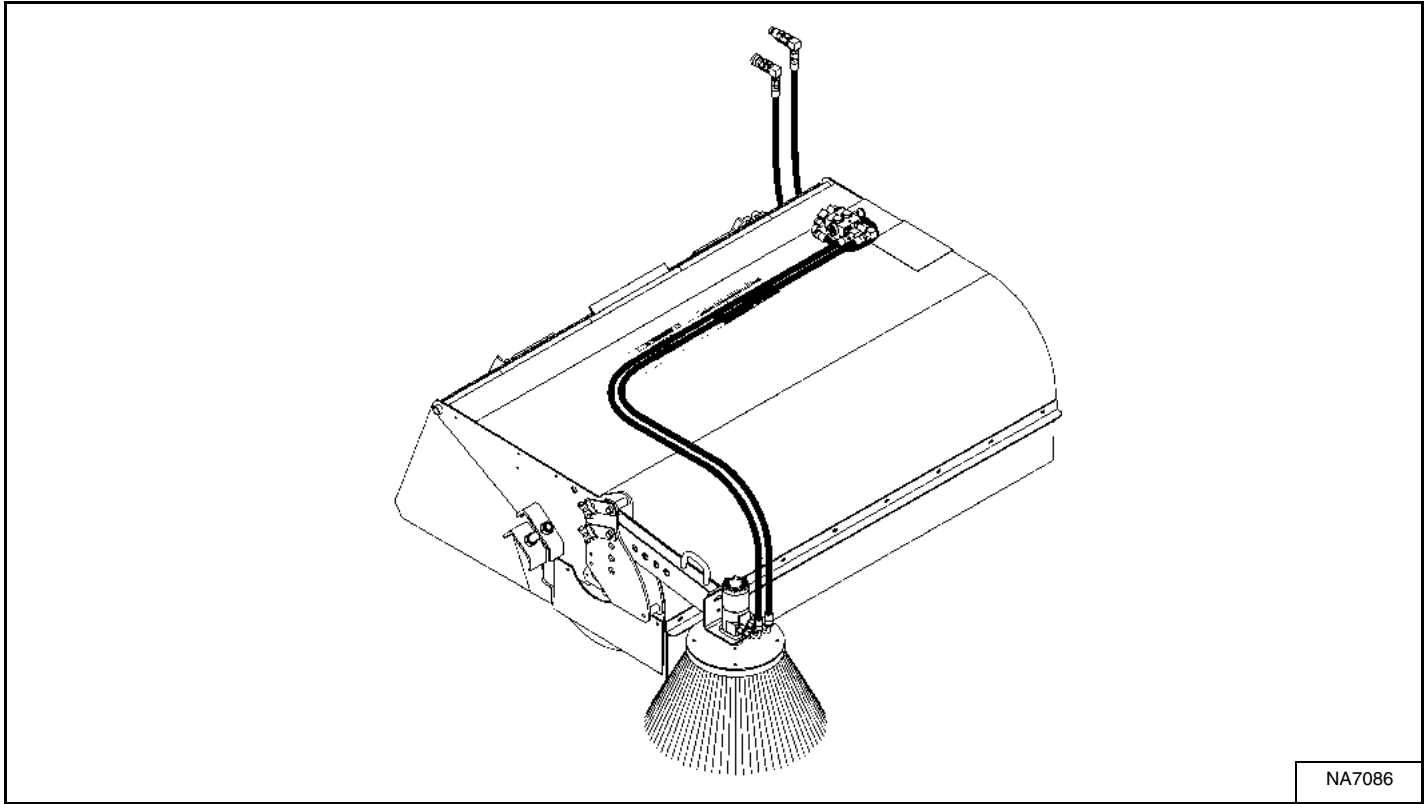

	54 SWEEPER	60 SWEEPER	72 SWEEPER
Sweeping Width	1372 mm (54 in)	1524 mm (60 in)	1829 mm (72 in)
Overall Width of Sweeper	Not Applicable	2022 mm (79.62 in)	2327 mm (91.62 in)

Performance

	54 SWEEPER	60 SWEEPER	72 SWEEPER
Weight	Not Applicable	400 kg (883 lb)	440 kg (970 lb)
Brush Diameter	Not Applicable	609,6 mm (24 in)	609,6 mm (24 in)
Bristle Material	Not Applicable	Replaceable Steel Brush	Replaceable Steel Brush
Brush Hydraulic Motor Displacement	Not Applicable	370,6 cm ³ (22.6 in ³)	370,6 cm ³ (22.6 in ³)
Brush rpm @ 37,9 L/min (10 U.S. gpm)	Not Applicable	102 rpm	102 rpm

SWEEPER WITH OPTIONAL GUTTER BRUSH SPECIFICATIONS (CONT'D)

Hydraulic System

	54 SWEEPER	60 SWEEPER	72 SWEEPER
Hydraulic Motor Displacement	Not Applicable	370,6 cm ³ (22.6 in ³)	370,6 cm ³ (22.6 in ³)
Max Allowable Continuous Hydraulic Flow	Not Applicable	75,7 L/min (20 gpm)	75,7 L/min (20 gpm)

Capacities

	54 SWEEPER	60 SWEEPER	72 SWEEPER
Bucket Capacity	0,30 m ³ (10.8 ft ³)	0,34 m ³ (12.0 ft ³)	0,4 m ³ (14.4 ft ³)

WARRANTY

WARRANTY127



Bobcat®

WARRANTY

Bobcat Attachments

Bobcat Company warrants to its authorized dealers and authorized dealers of Bobcat Equipment Ltd., who in turn warrant to the original owner, that each new Bobcat attachment will be free from proven defects in material and workmanship for twelve (12) months after delivery by the authorized Bobcat dealer to the original buyer.

During the warranty period, the authorized Bobcat dealer shall repair or replace, at Bobcat Company's option, without charge for parts and labor, any part of the Bobcat product which fails because of defects in material or workmanship. The owner shall provide the authorized Bobcat dealer with prompt written notice of the defect and allow reasonable time for replacement or repair. Bobcat Company may, at its option, require failed parts to be returned to the factory. Travel time of mechanics and transportation of the Bobcat product to the authorized Bobcat dealer for warranty work are the responsibility of the owner. The remedies provided in this warranty are exclusive.

This warranty does not cover replacement of scheduled service items and high wear items. The owner shall rely solely on the warranty, if any, of the respective manufacturers thereof. This warranty does not cover damages resulting from abuse, accidents, alterations, use of the Bobcat product as an attachment on any equipment not approved by Bobcat Company, air flow obstructions, or failure to maintain or use the Bobcat product according to the instructions applicable to it.

THIS WARRANTY IS EXCLUSIVE AND IN LIEU OF ALL OTHER WARRANTIES AND CONDITIONS, EXCEPT THE WARRANTY OF TITLE. BOBCAT COMPANY DISCLAIMS ALL OTHER WARRANTIES AND CONDITIONS, EXPRESS OR IMPLIED, INCLUDING ANY IMPLIED WARRANTIES OR CONDITIONS OF MERCHANTABILITY OR FITNESS FOR A PARTICULAR PURPOSE. IN NO EVENT SHALL BOBCAT COMPANY OR THE AUTHORIZED BOBCAT DEALER BE LIABLE FOR ANY SPECIAL, INCIDENTAL, INDIRECT OR CONSEQUENTIAL DAMAGES, WHATSOEVER, INCLUDING, BUT NOT LIMITED TO, LOSS OR INTERRUPTION OF BUSINESS, LOST PROFITS, OR LOSS OF MACHINE USE, WHETHER BASED ON CONTRACT, WARRANTY, TORT, NEGLIGENCE, STRICT LIABILITY, STATUTE OR OTHERWISE, EVEN IF BOBCAT COMPANY OR THE AUTHORIZED BOBCAT DEALER HAS BEEN ADVISED OF THE POSSIBILITY OF SUCH DAMAGES. THE TOTAL LIABILITY OF BOBCAT COMPANY AND THE AUTHORIZED BOBCAT DEALERS WITH RESPECT TO THE PRODUCT AND SERVICES FURNISHED HEREUNDER SHALL NOT EXCEED THE PURCHASE PRICE OF THE PRODUCT UPON WHICH SUCH LIABILITY IS BASED.





Bobcat®

ALPHABETICAL INDEX

ATTACHMENT IDENTIFICATION	8
ATTACHMENT SIGNS (DECALS)	18
ATTACHMENT STORAGE AND RETURN TO SERVICE	111
BOBCAT COMPANY IS ISO 9001 CERTIFIED	5
DAILY INSPECTION	24
DELIVERY REPORT	7
FEATURES AND ACCESSORIES	10
FIRE PREVENTION	15
INITIAL SETUP	23
LIFTING THE ATTACHMENT	91
MACHINE SIGN TRANSLATIONS	115
MAINTENANCE SAFETY	95
OPERATING PROCEDURE WITH LOADERS	28
OPERATING PROCEDURE WITH UTILITY WORK MACHINES	68
OPERATING PROCEDURE WITH VERSAHANDLERS	53
PUBLICATIONS AND TRAINING RESOURCES	17
REGULAR MAINTENANCE	98
REMOVAL AND INSTALLATION DRIVE CHAIN	107
REMOVAL AND INSTALLATION GUTTER BRUSH BRISTLES	108
REMOVAL AND INSTALLATION OF BROOM	101
SAFETY INSTRUCTIONS	13
SERIAL NUMBER LOCATION	7
SWEEPER SPECIFICATIONS	121
SWEEPER WITH OPTIONAL GUTTER BRUSH SPECIFICATIONS	123
TRANSPORTING THE ATTACHMENT AND MACHINE ON A TRAILER	92
TRANSPORTING THE ATTACHMENT ON A TRAILER	91
TROUBLESHOOTING	97
WARRANTY	127



Bobcat®



WARNING: Cancer and Reproductive Harm.

For more information go to www.P65Warnings.ca.gov.