

# DYNAPAC CA152 OPERATION

O152EN3

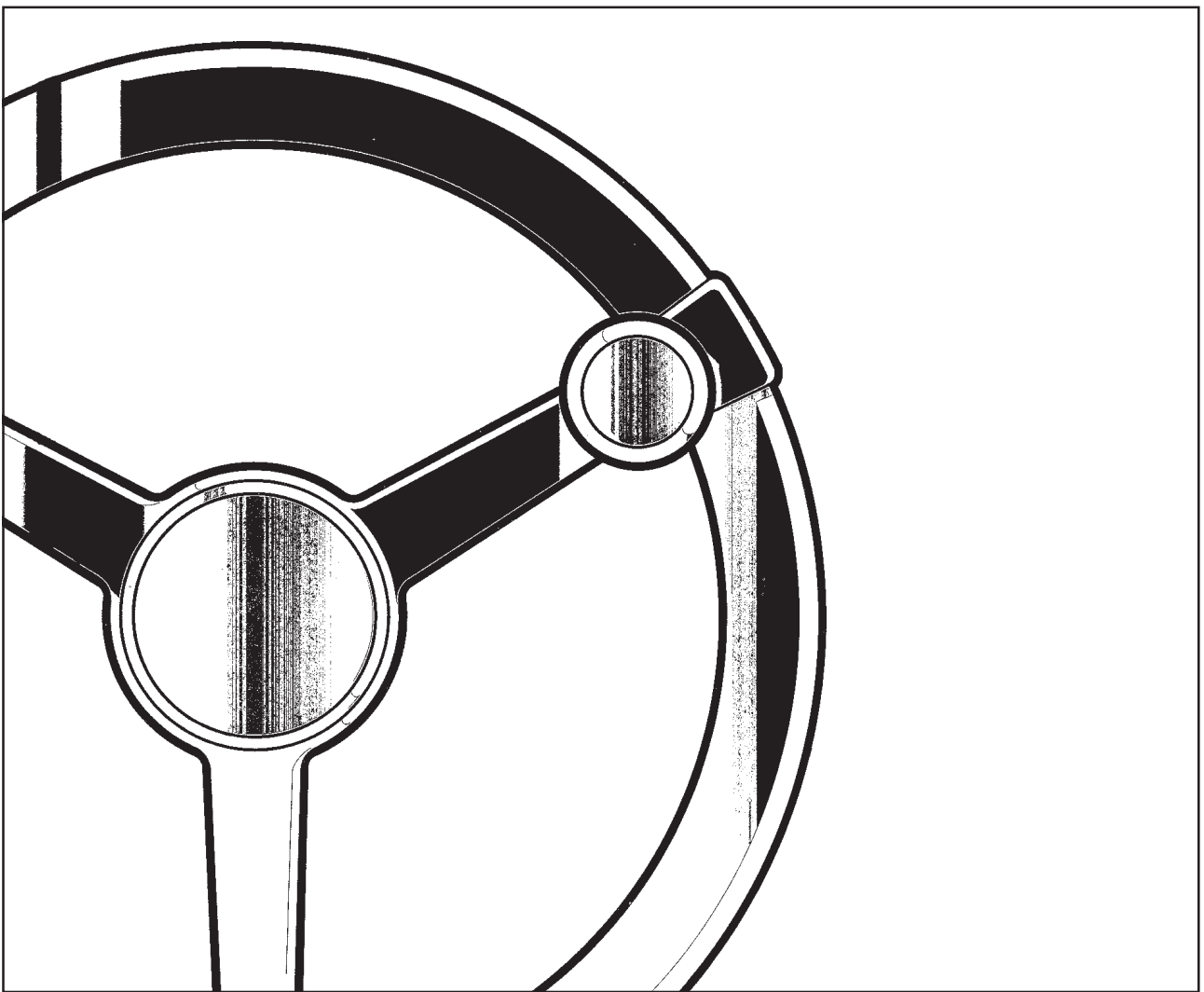

**DYNAPAC**  
Metso Dynapac AB

Box 504, SE-371 23 Karlskrona, Sweden  
Phone: +46 455 30 60 00, Fax: +46 455 30 60 30  
[www.dynapac.com](http://www.dynapac.com)



# **DYNAPAC**

## **Vibratory Roller CA152**

### **Operation O152EN3, December 2003**

**Diesel engine:  
CA152: Cummins 4B 4.5**

**These instructions apply from:  
C 152      PIN (S/N) \*64X21600\***

**KEEP THIS MANUAL FOR  
FUTURE REFERENCE**

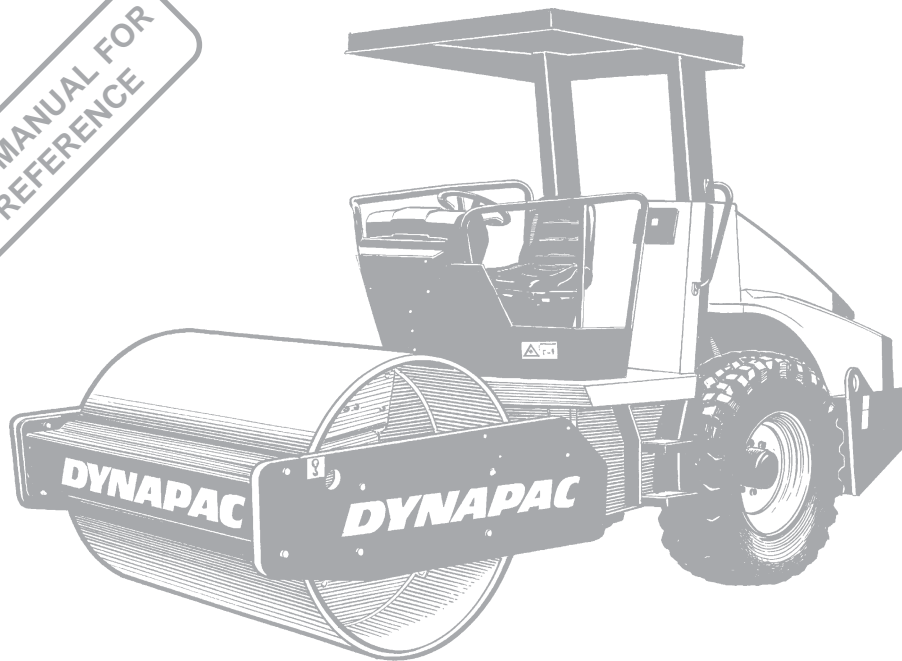

*CA152 is Dynapac's light vibratory soil compactor. Available in STD, D (smooth drum) and P, PD (padfoot) versions. The P, PD version has its widest range of application on cohesive material and rockfill materials.*

*All types of supporting and reinforcement courses can be compacted, and the interchangeable drums, ie, D to PD and vice versa, give enhanced versatility in the choice of application.*

*This manual describes the cab and safety-related accessories. Other accessories, such as the compaction meter, tachograph and field computer, are described in separate instructions.*

## CONTENTS

	Page
Safety instructions (Read the Safety Manual also) .....	3
Safety when driving .....	4
Safety (optional) .....	5
Safety decals, location/description .....	6, 7
Machine and engine plates .....	8
Instruments and controls .....	9
Instruments and controls, functional description .....	10-12
Controls in the cab .....	13
Controls in the cab, functional description .....	14
Before starting .....	15-17
Starting .....	18
Driving .....	19
Vibrating/driving .....	20
Driving .....	21
Braking .....	22
Parking .....	23
Lifting .....	24
Towing .....	25, 26
Towing/Retrieval .....	27
Transport .....	27
Operating instructions - Summary .....	28

## WARNING SYMBOLS

WARNING



**Safety instructions – Personal safety**

CAUTION



**Special caution – Machine or component damage**

## SAFETY MANUAL

WARNING



**The safety manual, which accompanies each machine, must be studied by each operator of the roller. Always follow the safety rules and do not remove the manual from the roller.**

## GENERAL

This manual contains instructions concerning operation and use of the roller. For information regarding care and maintenance, see the manual, "MAINTENANCE, CA 152".

WARNING



**When starting up and driving a cold machine, which implies cold hydraulic fluid, the braking distance will be longer than normal until the machine reaches normal working temperature.**

### CALIFORNIA

#### Proposition 65 Warning

Diesel engine exhaust and some of its constituents are known to the State of California to cause cancer, birth defects, and other reproductive harm.

## SAFETY INSTRUCTIONS (Read the Safety Manual also)



1. The operator must be familiar with the contents of the OPERATION MANUAL before starting the roller.
2. Make sure that all instructions in the MAINTENANCE MANUAL are followed.
3. Only trained and/or experienced operators may drive the roller. Passengers are not allowed on the roller. Remain seated during all operation.
4. Never use the roller if it is in need of adjustment or repairs.
5. Board and leave the roller only when it is stationary. Use the grips and railings that are provided. Always use a "three-point grip" - both feet and one hand or one foot and both hands - when boarding or exiting the machine.
6. The ROPS (Roll Over Protective Structure) should always be used when the machine is operated on risky ground.
7. Drive slowly in sharp bends.
8. Avoid driving at an angle on slopes; drive straight up or down.
9. When driving close to unsafe edges or holes, make sure that at least two thirds of the drum width is firmly on material that has already been compacted.
10. Make sure that there are no obstacles in the direction of travel, on the ground or overhead.
11. Drive extra carefully on uneven ground.
12. Use the safety equipment provided. The seat belt must be worn on machines fitted with ROPS.
13. Keep the roller clean. Clean dirt and grease from the operator's platform without delay. Keep all signs and decals clean and clearly legible.
14. Safety measures before refueling:
  - Stop the engine.
  - Do not smoke.
  - No naked flame in the vicinity.
  - Ground the nozzle of the filling device against the tank to prevent sparks.
15. Before repairs or service:
  - Place chocks against the drums/wheels and against the strike-off blade.
  - Lock the articulation if required.
16. Hearing protectors are recommended if the noise level exceeds 85 dB(A). The noise level may vary depending on what material the machine is operating on.
17. Make no changes or modifications on the roller that could affect safety. Changes may only be made following written consent by Dynapac.
18. Do not use the roller until the hydraulic fluid has reached its normal working temperature. Braking distance can be longer than usual if the fluid is cold. See starting instructions in the OPERATION MANUAL.

## SAFETY WHEN DRIVING

### Driving near an edge

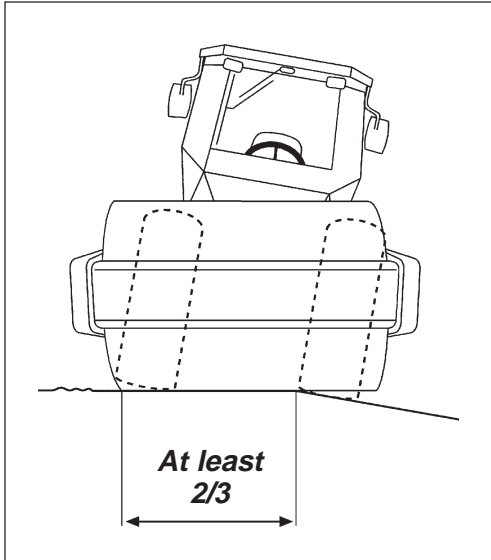

Fig. 1 Position of drum when driving near an edge

When you drive near an edge, at least two thirds of the drum width must be on solid ground.



**Remember that the machine's center of gravity is displaced outward when you steer to one side. For example, it shifts to the right when you steer to the left.**

### Slopes

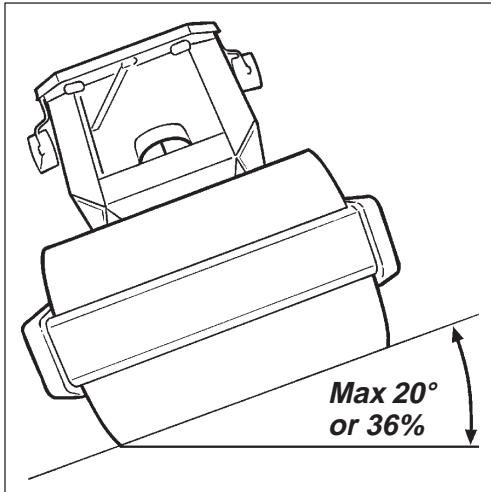

Fig. 2 Tipping angle on side slopes



**The ROPS (Roll Over Protective Structure) is always recommended when driving on slopes or insecure ground.**



**Where possible, avoid all driving across a slope. Instead, drive up and down on sloping ground.**

The tilting angle is measured on a hard, level surface with the machine stationary, steering angle zero, vibration switched OFF and all tanks full. Remember that loose ground, steering of the machine, vibration switched ON, driving speed and raising the center of gravity (for example, with accessories) may cause the machine to topple even on a smaller slope than that stated here.



**To leave the cab in an emergency, release the hammer located on the rear right post and break the rear window.**

## SAFETY (OPTIONAL)

### Strike-off blade

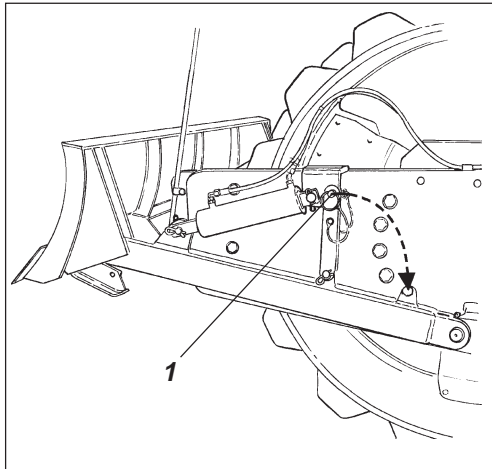

**Fig. 3 Strike-off blade**  
1. Locking pin

WARNING



**The operator must make sure that nobody is in the working area while the machine is in operation.**

CAUTION



The strike-off blade must be retracted to its transportation mode (1) at the end of each working period.

WARNING



**Ensure always that the strike-off blade is secured by the locking pin (1) when driving with the blade in its raised position. Always lower the blade to the ground before leaving or parking the roller.**

### Air conditioning

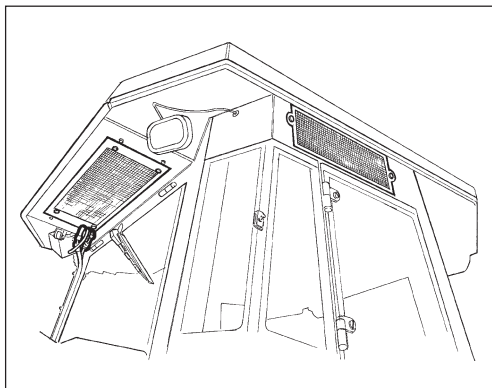

**Fig. 4 Cab**

The system described in this manual is of the ACC type (Automatic Climate Control)

WARNING



**The system contains pressurized refrigerant. Releasing refrigerants into the air is prohibited. The refrigerant circuit may only be repaired by an authorized company.**

WARNING



**The cooling system is pressurized. Incorrect handling can result in serious personal injury. Do not disconnect the hose coupling.**

CAUTION



Recharge the system with approved refrigerant when required.

**SAFETY DECALS, LOCATION/DESCRIPTION**

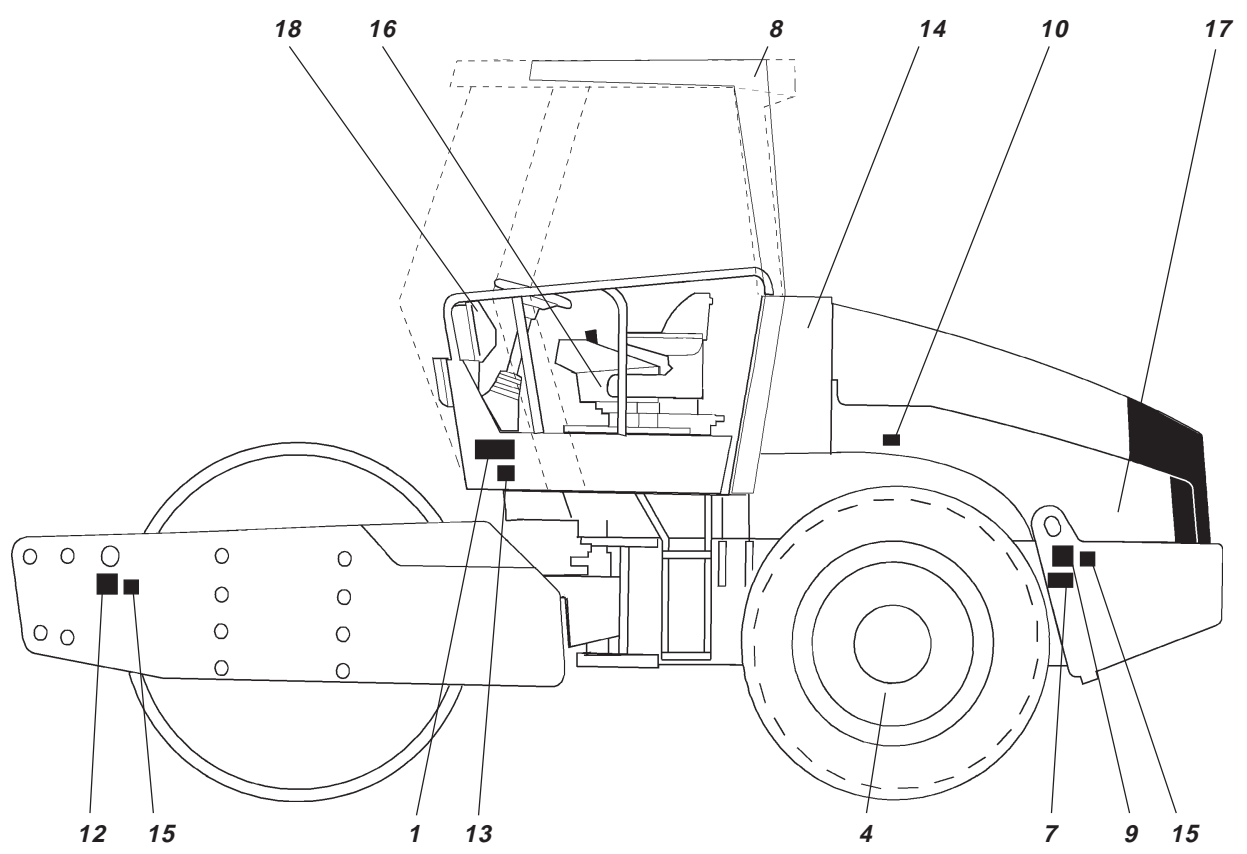
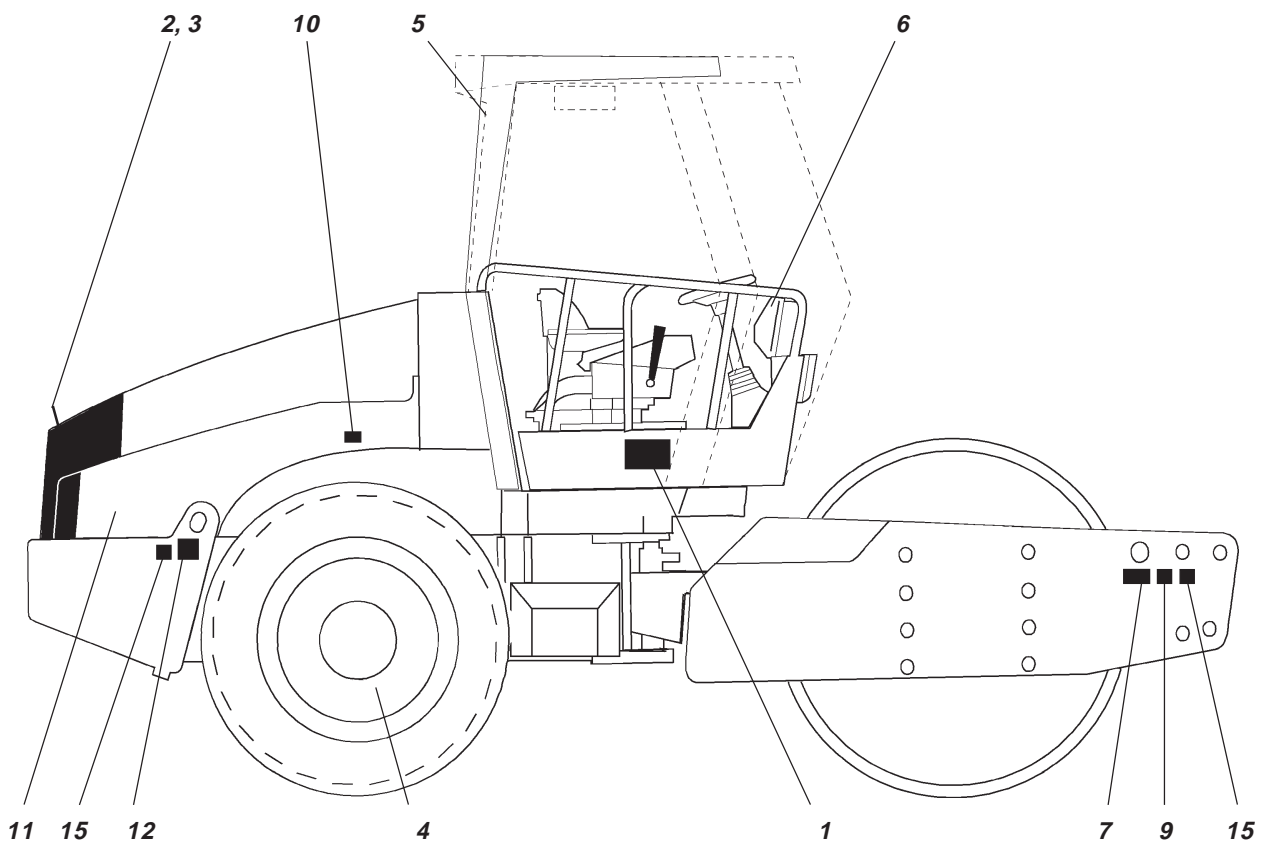



# SAFETY DECALS, LOCATION/DESCRIPTION



1. Crush zone, articulation/ Drum. Maintain a safe distance from the crush zone.



6. The operator is urgently requested to read the safety manual, and the operation and maintenance instructions before using the machine.

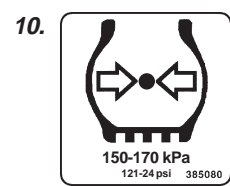

10. Tire pressure



2. Warning - rotating engine components. Keep your hands at a safe distance from the danger zone.

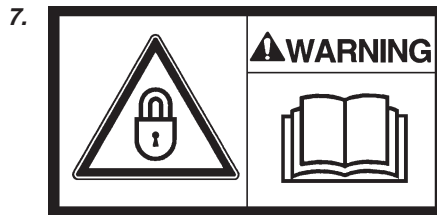

7. The articulation must be interlocked when lifting. Read the instruction manual.



11. Diesel fuel



3. Warning - hot surfaces in the engine compartment. Do not touch.

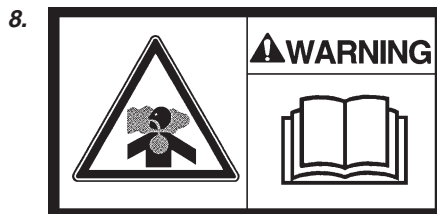

8. Toxic gas. Read the instruction manual.

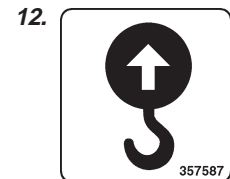

12. Lifting point

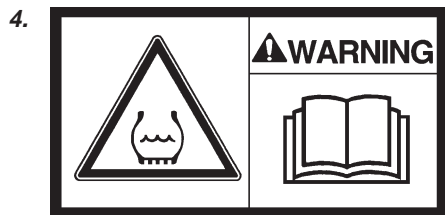

4. Tires filled with ballast (Optional). Read the instruction manual.

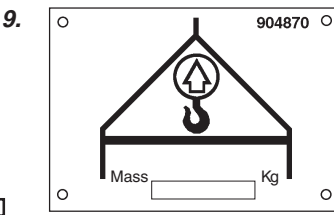

9. Lifting plate

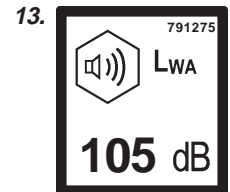

13. Sound Power level

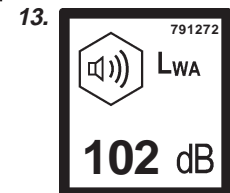

13. Sound Power level LN-version



5. Emergency exit

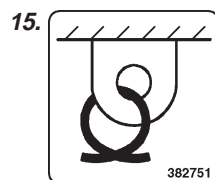

15. Securing point

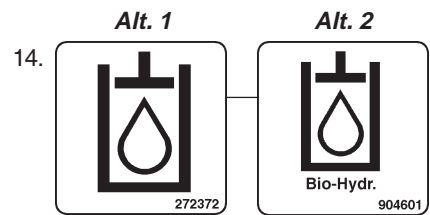

14. Hydraulic fluid

14. Biological hydraulic fluid

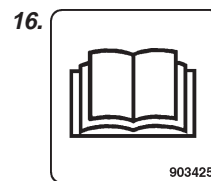

16. Handbook compartment

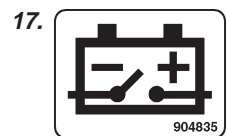

17. Battery disconnect



□ = Optional





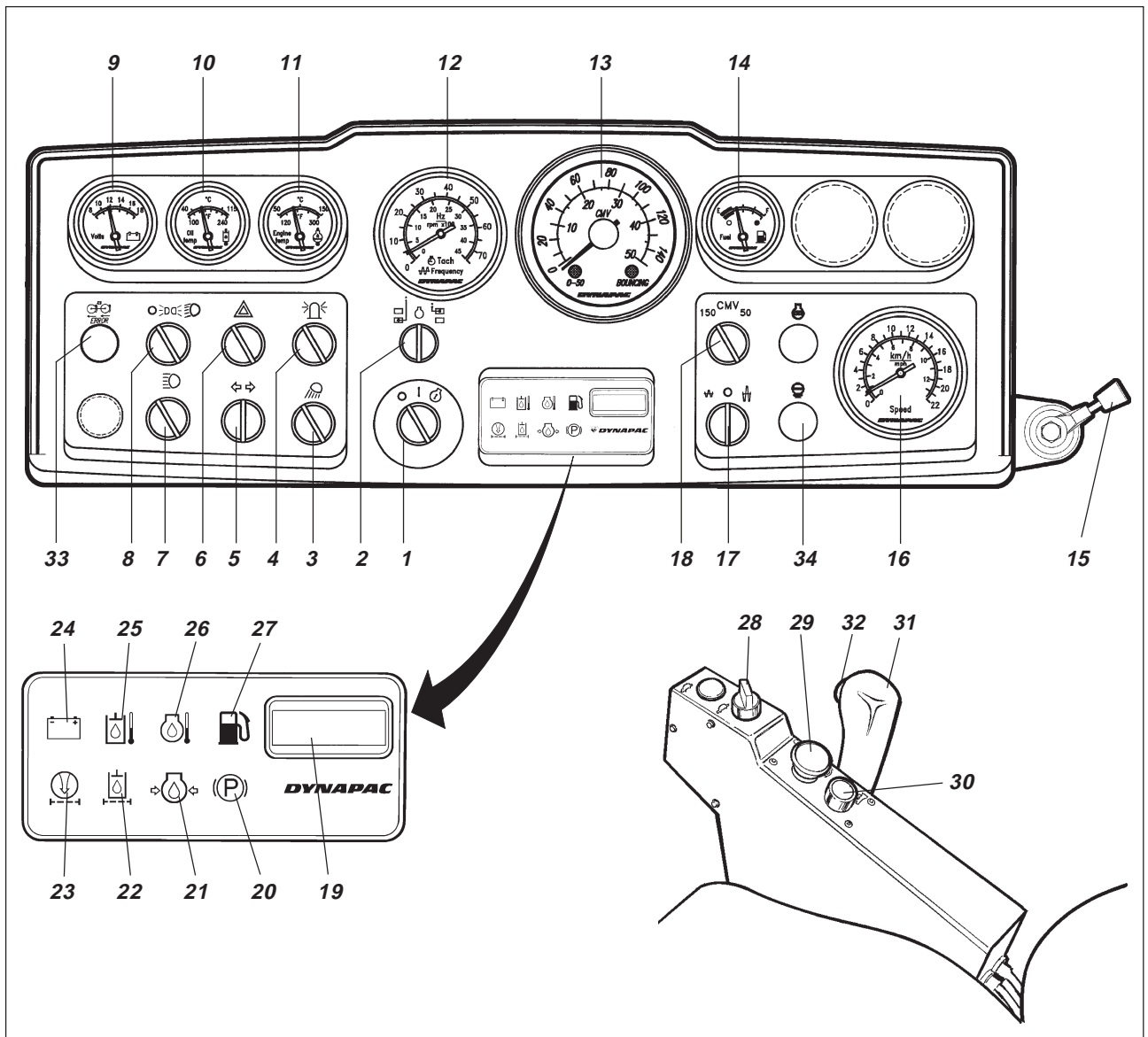













# INSTRUMENTS AND CONTROLS













**Fig. 8 Instruments and control panel**

- |  |  |                                      |
|--|--|--------------------------------------|
| 1. Starter switch                                | 14. Fuel gauge   | 26. Warning lamp, engine temperature |
| 2. Revs/Frequency selector □                     | 15. Engine revs control  | 27. Warning lamp, fuel level         |
| 3. Working lights □                              | 16. Speedometer (If compaction meter is included in item 13) □ | 28. Speed selector, rear axle        |
| 4. Hazard beacon □                               | 17. Amplitude selector Low/0/High                              | 29. Reserve/Parking brake knob       |
| 5. Direction indicator switch □                  | 18. CMV selector □   | 30. Horn                             |
| 6. Hazard flashers □                             | 19. Hourmeter  | 31. Forward/Reverse lever            |
| 7. Main beam switch □                            | 20. Brake warning lamp   | 32. Vibration ON/OFF                 |
| 8. Parking/dipped beam switch □                  | 21. Warning lamp, engine oil pressure                          | 33. Anti-spin, Fault Indication □    |
| 9. Voltmeter □                                   | 22. Warning lamp, hydraulic filter                             | 34. Preheating lamp                  |
| 10. Hydraulic temperature □                      | 23. Warning lamp, air filter                                   |                                      |
| 11. Engine temperature □                         | 24. Warning lamp, charging                                     |                                      |
| 12. Engine revs/Vibration frequency □            | 25. Warning lamp, hydraulic temperature                        |                                      |
| 13. Compaction meter/Speedometer (see item 16) □ |  | □ = Optional                         |







## INSTRUMENTS AND CONTROLS, FUNCTIONAL DESCRIPTION

Item in fig. 8	Designation	Symbol	Function
1	Starter switch		<p>In mode  the electric circuit is broken.</p> <p>In mode  all instruments and electric controls are powered.</p> <p>In mode  the starter motor is energized.</p>
2	Engine revs/Frequency selector (Optional)		<p>In mode  the engine revs are shown on instrument 12.</p> <p>In the right mode the vibration frequency is shown on instrument 12. (The left mode has no function.)</p>
3	Working lights rear, switch (Optional)		Turn to the right to switch on the working lights.
4	Hazard beacon, switch (Optional)		Turn to the right to switch on the hazard beacon.
5	Direction indicator, switch (Optional)		<p>Turn to the left to make the left direction indicator flash, etc.</p> <p>The flashing function is switched off in the middle mode.</p>
6	Hazard flashers, switch (Optional)		Turn to the right to switch on the hazard flashers.
7	Main/Dipped beam, switch with control lamp (Optional)		<p>Turn to the right to switch on the main beam and to illuminate the switch.</p> <p>Turn to the left to switch on the dipped beam.</p>
8	Driving lighting, switch (Optional)		When turned right, the first setting switches on the parking light, the second setting activates low beam.
9	Voltmeter, (Optional)		Indicates voltage of the electrical system. Normally 12–15 volt.
10	Temperature gauge, hydraulic fluid, (Optional)		<p>Indicates temperature of hydraulic fluid. Normal temperature range 65°C to 80°C (149°F to 176°F). Stop the engine if the meter reading exceeds 85°C (185°F). Locate and remedy the fault.</p>
11	Temperature gauge, engine, (Optional)		<p>Indicates engine temperature. Normal temperature is about 90°C (194°F). Stop the engine if the gauge indicates a temperature higher than 103°C (217°F). Locate and remedy the fault.</p>
12	Engine revs/Frequency meter, (Optional)		The inner scale shows the actual engine speed. The outer scale shows the vibration frequency.

## INSTRUMENTS AND CONTROLS, FUNCTIONAL DESCRIPTION

Item in fig. 8	Designation	Symbol	Function
13	Compaction meter (Optional)	—	See separate instructions.
14	Fuel gauge		Indicates fuel level.
15	Revs control (diesel engine)	—	Upper mode, engine working revs. Lower mode, idling revs.
16	Speedometer (Optional)		The outer scale shows roller speed in km/h. The inner scale shows roller speed in mph.
17	Amplitude selector		Left mode gives low amplitude. Right mode gives high amplitude. Vibration switched OFF in 0 mode.
18	CMV selector (Optional)	—	Mode 150 gives reading on outer scale. Mode 50 gives reading on inner scale.
19	Hourmeter	—	Engine running time is indicated in hours.
20	Brake warning lamp		This lamp will light when the parking or reserve brake knob is pressed and the brakes are applied.
21	Warning lamp, oil pressure		This lamp lights if lubricating pressure in the engine is too low. Stop the engine <b>immediately</b> and locate the fault.
22	Warning lamp, hydraulic filter		If the lamp lights up when the diesel engine is running at full speed, the hydraulic fluid filters must be replaced.
23	Warning lamp, air filter		The air filter should be cleaned or replaced if this lamp lights when the engine is running at full speed.
24	Warning lamp, battery charging		The alternator is not charging if this lamp lights when the engine is running. Stop the engine and locate the fault.
25	Warning lamp, hydraulic temperature		This lamp lights if the hydraulic fuel is too hot. Stop the roller, and allow the fluid to cool down by idling the engine. Locate and remedy the fault.
26	Warning lamp, engine temperature		This lamp lights if the engine is too hot. Stop the engine <b>immediately</b> and locate and remedy the fault. See also the engine manual.
27	Warning lamp, low fuel level		This lamp lights when there is only sufficient fuel left for a short period. Refuel without delay.

## INSTRUMENTS AND CONTROLS, FUNCTIONAL DESCRIPTION

Item in fig. 8	Designation	Symbol	Function
28	Speed selector, rear axle		Transport speed (High) Working speed (Low)
29	Reserve brake/Parking brake		Push in to activate the reserve brake. Parking brake is applied if pushed in when machine is stationary. Both brakes are released when knob is pulled out.
30	Horn, switch		Press to sound the horn.
31	Forward/Reverse control		The lever must be in neutral to start the engine, it cannot be started with the forward/reverse lever in any other position. Direction of travel and speed of the roller is regulated with the forward/reverse lever. The roller moves forward when the lever is moved forward, etc. Speed of the roller is regulated in proportion to how far the lever is moved from neutral. The further from neutral, the higher the speed.
32	Vibration ON/OFF, switch		Push and release the switch to engage vibration, push once more to disengage vibration. The above applies only when the amplitude selector (17) is in position High or Low.
33	Warning lamp, malfunctioning anti-spin function (Optional)		The hydraulic propulsion system is not working satisfactorily if the lamp flashes. Locate and remedy the fault.
34	Preheating lamp		Lights while preheating of the diesel engine is in progress and the starter switch is in mode I.

# CONTROLS IN THE CAB

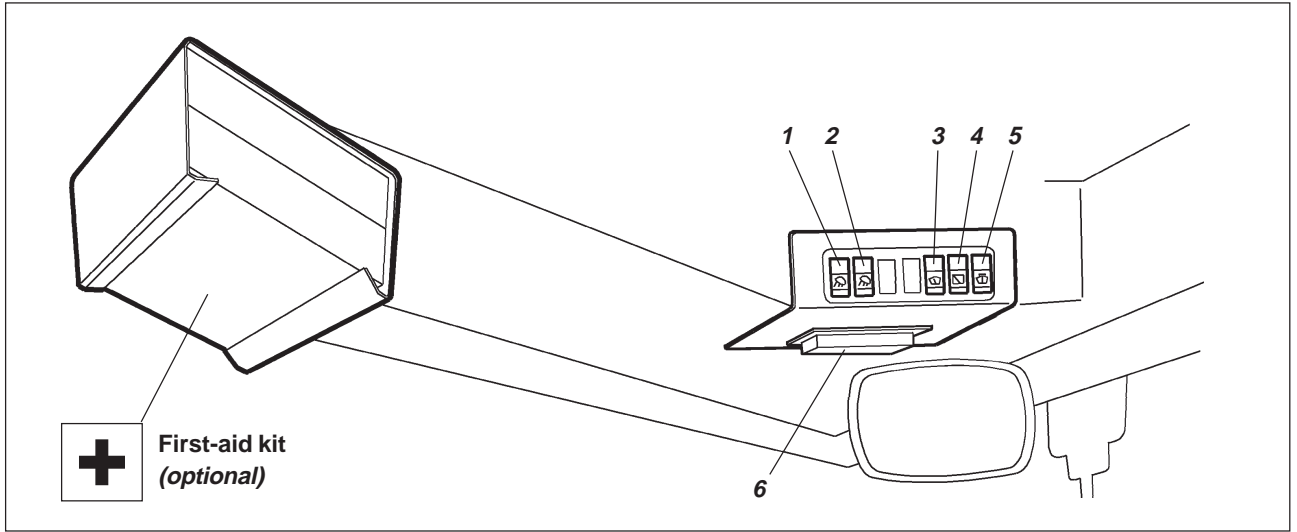

Fig. 9a Cab roof, front

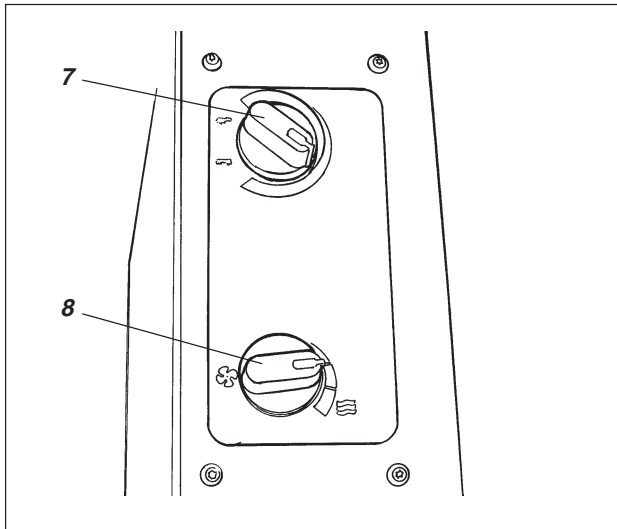

Fig. 9b Cab, right side

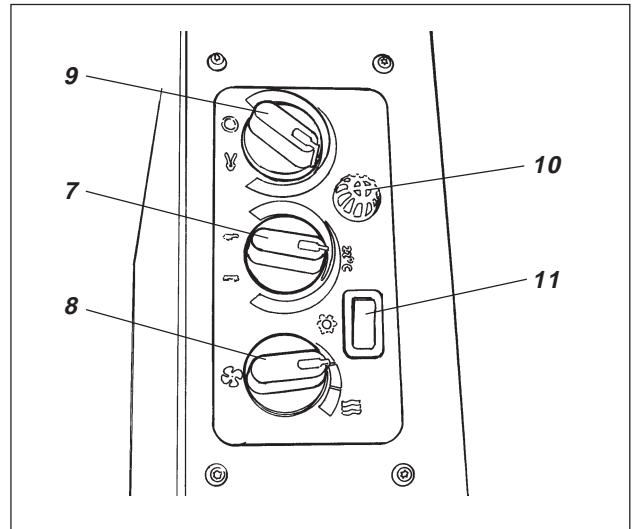

Fig. 9c Cab, right side (with AC option)

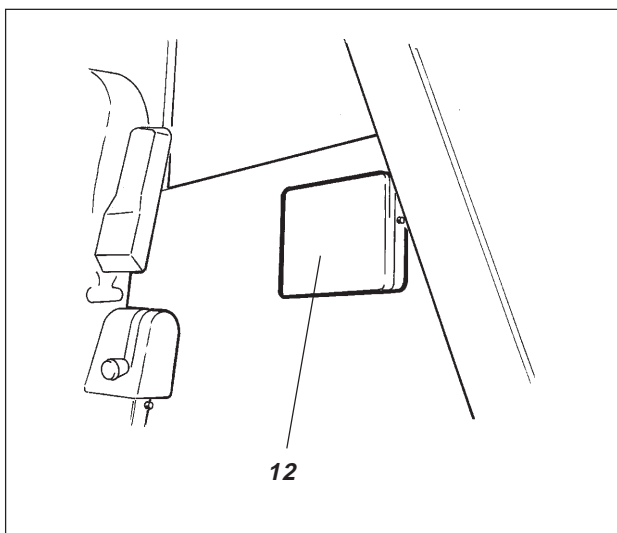

Fig. 9d Cab, rear

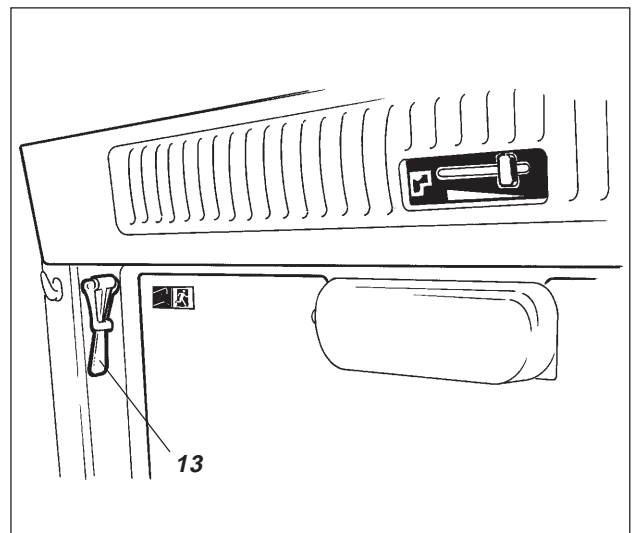















Fig. 9e Cab roof, rear

## CONTROLS IN THE CAB, FUNCTIONAL DESCRIPTION

Item in fig. 9	Designation	Symbol	Function
1	Working lights front, switch		Press to turn on the forward working lights.
2	Working lights rear, switch		Press to turn on the rear working lights.
3	Wiper front, switch		Press to turn on the front wiper.
4	Wiper rear, switch		Press to turn on the rear wiper.
5	Screenwash front and rear panes, switch		Press at the top to spray the windscreen. Press at the bottom to spray the rear screen.
6	Fuse box (cab)		Contains fuses for the electrical system. See the "Electrical system" section in the Maintenance Manual for functional descriptions of the fuses.
7	Heater		Right-hand position for maximum heating. In the left-hand position the heating is OFF.
8	Air fan, switch		In the left-hand position the fan is OFF. In the right-hand position the amount of air to the cab increases in three steps.
9	Recirculation of air in cab, switch		Left mode, maximum recirculation of air. Right mode, minimum.
10	Temperature sensor		Senses the interior temperature. Must not be covered.
11	Air conditioning switch		Starts and stops the air conditioner.
12	Handbook compartment		Stowage space for safety manual and operator's manuals.
13	Hammer for emergency evacuation		To evacuate the cab in an emergency, release the hammer and break the <b>REAR</b> window.



## BEFORE STARTING

### Battery disconnecter – Switching ON

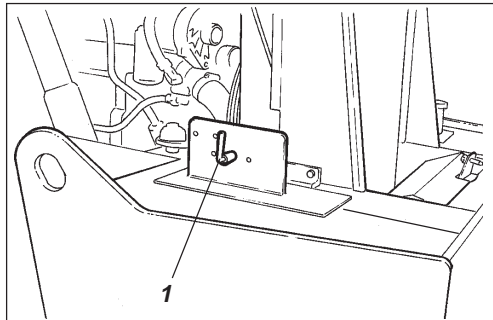

**Fig. 10 Engine compartment**  
1. Battery disconnecter

Remember to carry out daily service. See maintenance manual.

The battery disconnecter is located in the engine compartment. Open the engine cover and set the key (1) to the ON position. The entire roller will be powered.



**WARNING**  
The engine hood must be unlocked during operation, so that battery power can be disconnected quickly if necessary.

### Operator's seat – Setting

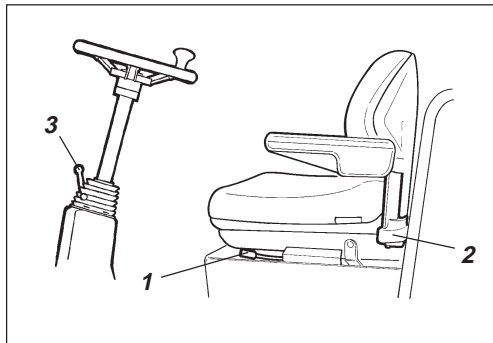

**Fig. 11 Operator's seat**  
1. Locking lever - length adjustment  
2. Lever - weight adjustment  
3. Locking lever - slope of steering wheel

Adjust the operator's seat to ensure a comfortable posture and so that all controls are within easy reach.

The seat can be adjusted as follows:

- Length adjustment (1)
- Cushioning to suit weight of operator (2)

Release the locking lever (3) to adjust the steering column to the desired slope and then lock the steering column in its new position.



**WARNING**  
Always make sure that the seat is secure before beginning operation.

### Control unit (Optional) – Setting

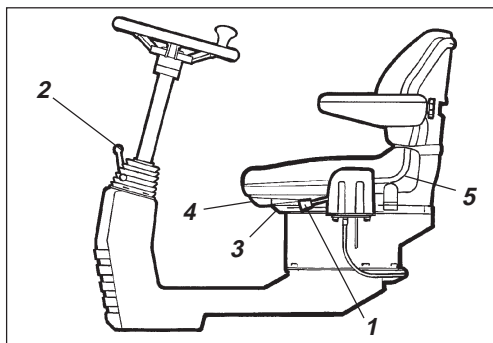

**Fig. 12 Operator's station**  
1. Locking lever - rotation (Optional)  
2. Locking lever - slope of steering wheel  
3. Locking lever - length adjustment  
4. Lever - seat back slope  
5. Lever - weight adjustment

The control unit has two modes of adjustment, ie, rotation and slope of steering wheel.

Pull the lever (1) upwards to allow rotation.

Release the locking lever (2) to adjust the steering column to the desired slope and then lock the steering column in its new position.

The seat can be adjusted as follows:

- Length adjustment (3).
- Seat back slope (4).
- Cushioning to suit weight of operator (5).



**WARNING**  
Always make sure that the seat is secure before beginning operation.

## BEFORE STARTING

### Operator's seat in cab – Setting

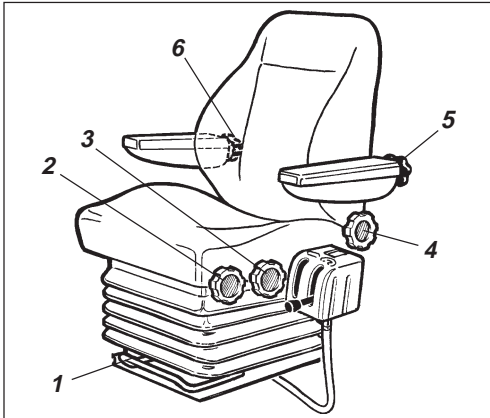

**Fig. 13 Operator's seat**

1. Lever - length adjustment
2. Knob - height adjustment
3. Knob - seat cushion slope
4. Knob - seat back slope
5. Knob - armrest slope
6. Knob - lumbar adjustment

Adjust the operator's seat to ensure a comfortable posture and so that all controls are within easy reach.

The seat can be adjusted as follows:

- Length adjustment (1).
- Height adjustment (2).
- Slope of seat cushion (3).
- Seat back slope (4).
- Slope of armrests (5).
- Lumbar support (6).

WARNING



**Always make sure that the seat is secure before beginning operation.**

### Instruments and lamps – Checking

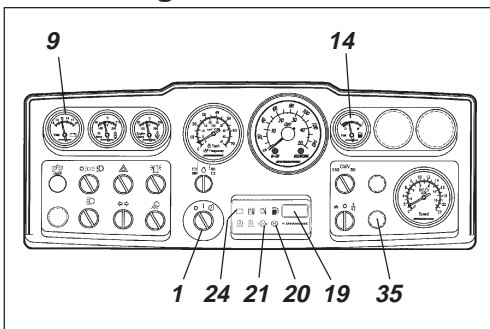

**Fig. 14 Instrument panel**

1. Starter switch
9. Voltmeter (Optional)
14. Fuel gauge
19. Hourmeter
20. Brake lamp
21. Oil pressure lamp
24. Charging lamp
34. Preheating lamp

Turn the starter switch (1) to position I. All warning lamps should light for about 5 seconds and the buzzer should sound. Make sure that the warning lamps light.

Check that the voltmeter (9) goes up to at least 12 volts, and also check that the level gauges (14) give a reading.

Check that the warning lamps for charging (24), oil pressure (21) and parking brake (20) light.

The hourmeter (19) records the number of hours so long as the engine is running.

The preheating lamp (34) should light.

### Parking brake – Check

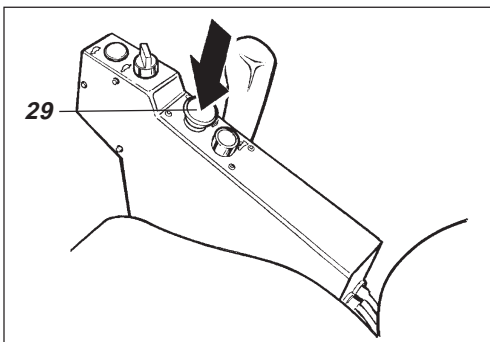

**Fig. 15 Controls panel**

29. Reserve/parking brake knob

WARNING



**Ensure that the reserve/parking brake knob (29) is pressed down.**

**The roller can start to move if the engine is started on sloping ground if the parking brake is not applied.**

### Interlock (optional)

The engine switches off 7 seconds after the operator rises from the seat. This will occur regardless of whether the forward/reverse lever is in neutral or the drive mode. The engine will not stop if the parking brake is activated.

## BEFORE STARTING

### Operator's station

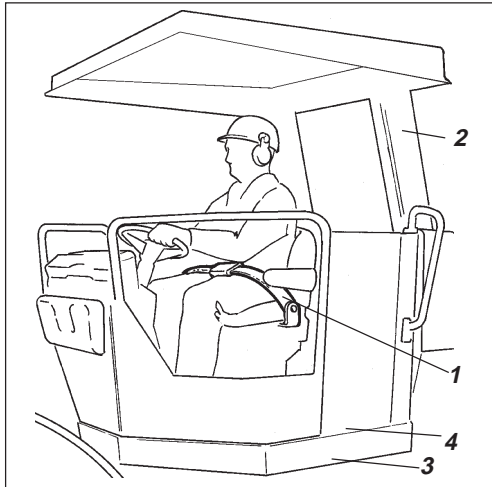

**Fig. 16 Operator's station**

- 1. Seat belt
- 2. ROPS
- 3. Rubber element
- 4. Anti-slip

If the roller is equipped with a ROPS (Roll Over Protective Structure) or a cab, always use the seat belt (1) and wear a hard hat.



**Replace the seat belt (1) if it shows signs of wear or has been subjected to severe force.**



**Check that the rubber elements (3) on the platform are intact. Worn elements will impair comfort.**



**Ensure that the anti-slip (4) on the platform is in good condition; replace with new anti-slip if friction is poor.**



**If the machine is fitted with a cab, make sure that the door is closed when in motion.**

### Field of view

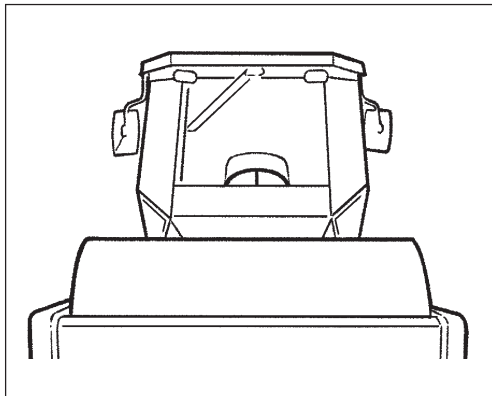

**Fig. 17 Field of view**

Before starting, make sure that the field of view is unobstructed, both in front and behind. All cab windows must be clean and rearview mirrors properly adjusted.

### Strike-off blade (Optional)

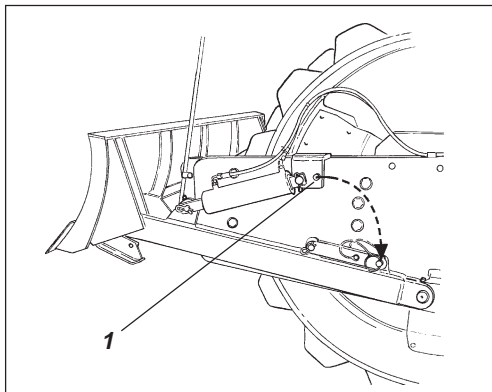

**Fig. 18 Strike-off blade**

- 1. Locking pin



**Always ensure that the strike-off blade is secured by the locking pin (1) when driving with the blade in its raised position. Always lower the blade to the ground before leaving/parking the roller.**

## STARTING

### Starting the engine

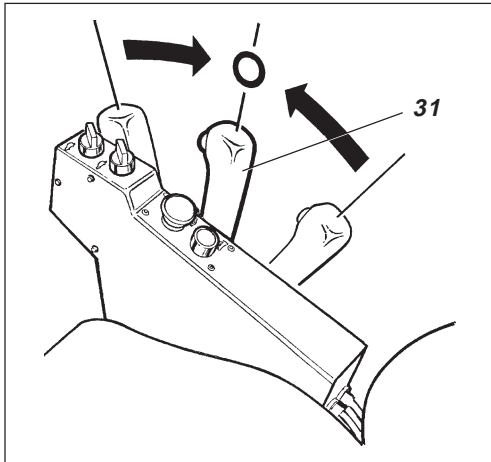

**Fig. 19 Control panel**  
31. Forward/reverse lever

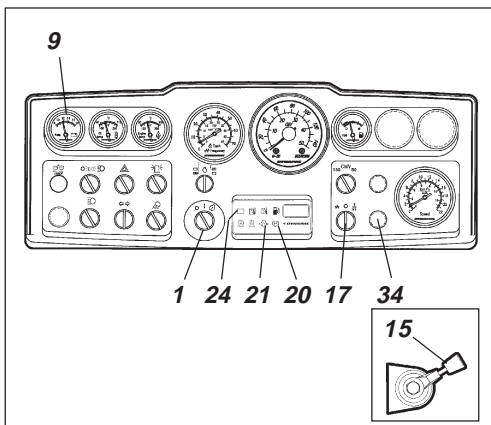

**Fig. 20 Instrument panel**  
1. Starter switch  
9. Voltmeter (Optional)  
15. Revs control  
17. Amplitude selector  
20. Brake lamp  
21. Oil pressure lamp  
24. Charging lamp  
35. Preheating lamp

Set the forward/reverse lever (31) in neutral. The engine can only be started with the lever in neutral.

Set the amplitude selector (17) for Low/High vibration to mode **O**.

Set the revs control (15) to the idling mode.

Turn the starter switch (1) to mode **I**. The preheating lamp (35) lights if the engine needs preheating before starting, ie, wait until the preheating lamp goes out before turning the starter switch to start.

Turn the starter switch (1) right to the starting mode, release the knob as soon as the engine fires.



**CAUTION**  
Do not run the starter motor too long. If the engine does not start immediately, wait a minute or so before making a new attempt.

Warm up the diesel engine with the engine speed control at the idling setting for a few minutes, or for a longer period if the ambient air temperature is below +10°C (+50°F).

Check while warming up that the warning lamps for oil pressure (21) and charging (24) are out, and that the voltmeter (9) shows 13–14 volt. The warning lamp (20) for the parking brake shall still light.



**WARNING**  
When starting up and driving a cold machine, ie, cold hydraulic fluid, the braking distance will be longer than normal until the fluid reaches normal working temperature.



**WARNING**  
Ensure that ventilation (evacuation) is adequate if the engine is run indoors, ie, danger of carbon monoxide poisoning.

## DRIVING

### Driving the roller

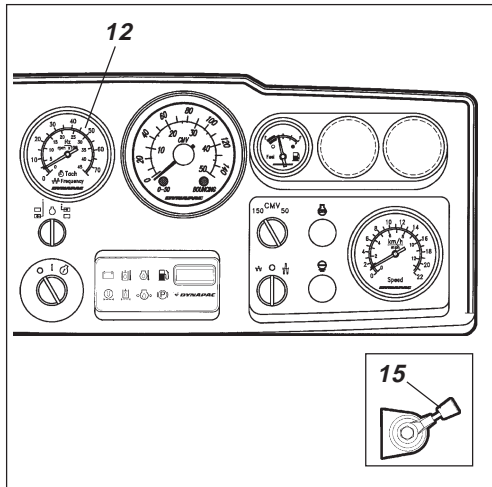

**Fig. 21 Instrument panel**  
12. Tachometer (Optional)  
15. Revs control

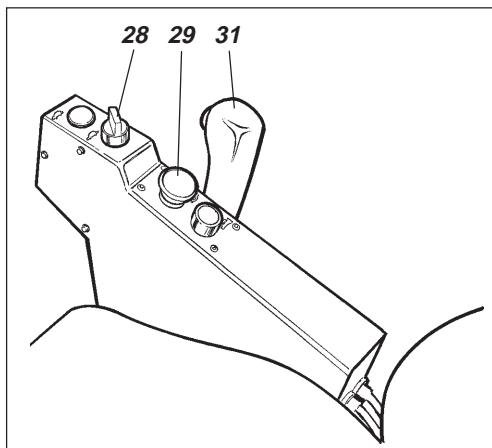

**Fig. 22 Control panel**  
28. Speed selector, rear axle  
29. Reserve/parking brake knob  
31. Forward/Reverse lever

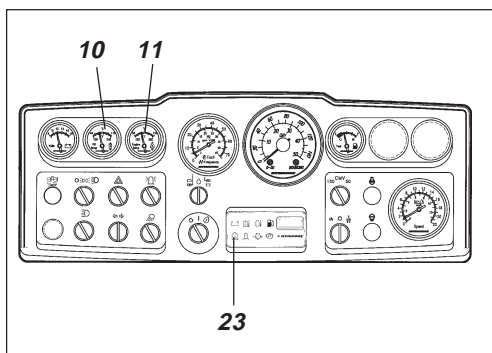

**Fig. 23 Instrument panel**  
10. Temperature, hydraulic fluid (Optional)  
11. Temperature, engine oil (Optional)  
23. Warning lamp, air filter

WARNING



**Under no circumstances may the machine be operated from the outside. The operator must remain seated inside the machine during all operation.**

Move the revs control lever (15) upwards and latch it at its limit, engine speed should now be about 2300 rpm.

Ensure that the steering is working properly by turning the steering wheel once to the right and once to the left while the roller is stationary.

WARNING



**Ensure that the area in front of and behind the roller is clear.**

WARNING



**Pull up the reserve/parking brake knob (29) and check that the warning lamp for the parking brake is out. When starting the roller on a slope, be prepared that it may begin to roll.**

Set the High/Low speed selectors (28) to the desired mode, see decal on the control panel.

### Max. speeds km/h (mph)

	Std	D	PD
	9 (6)	6 (4)	6 (4)
	20 (12)	12 (7)	12 (7)

WARNING



**The high setting may only be used for transport driving on a level surface.**

Carefully move the forward/reverse lever (31) in the desired direction of travel. Speed increases as the lever is moved farther from the neutral position.

CAUTION



Speed must always be regulated with the forward/reverse lever and **never** by changing speed of the engine.

WARNING



**Test the reserve brake by pressing the reserve/parking brake knob (29) while the roller is running slowly forward.**

Check now and then while driving that the gauges show normal readings. In the event of abnormal values or if the buzzer sounds, stop the roller and the engine immediately. Check and remedy any fault, see also the maintenance manual and the engine manual.

CAUTION



If the air filter warning lamp (23) should light while driving (at full engine revs), the main filter must then be cleaned or replaced, see Maintenance Manual.

## VIBRATING/DRIVING

### Low/High amplitude – Setting

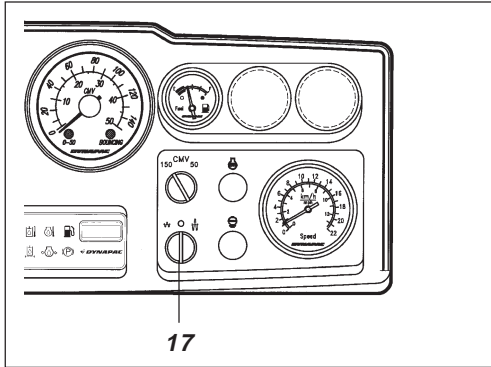

**Fig. 24 Instrument panel**  
17. Amplitude selector Low/0/High

Vibration on the drum can be set in two different modes with the changeover switch (17). Turn the knob to the left for low amplitude/high frequency and to the right for high amplitude/low frequency.



Amplitude setting may never be altered while vibration is in action. Switch off vibration and wait until it has ceased before altering the amplitude.

### Vibration – Engaging

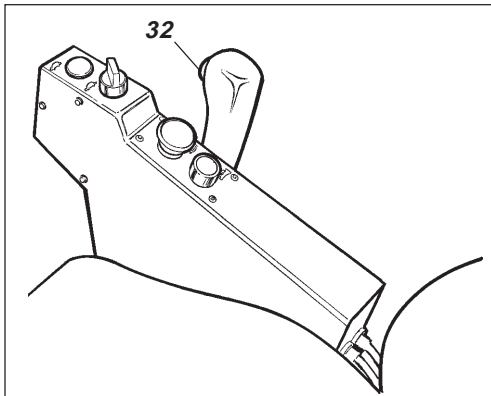

**Fig. 25 Control panel**  
32. Switch, vibration ON/OFF

Engagement and disengagement of vibration is made with the changeover switch (32) on the front of the forward/reverse lever. Always switch off vibration before the roller comes to a complete standstill.



Vibrating may never be performed when the roller is stationary, the surface and the machine may otherwise be damaged.

## Operating the strike-off blade

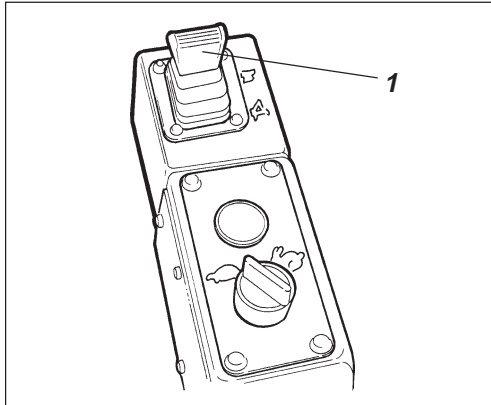

**Fig. 26 Controls**  
1. Lever

### Optional



**Before driving, make certain that the blade is in its uppermost position (raised). Inspect the condition of the ground before using the blade.**

The lever (1) has three positions.

Backward – Raising the blade.

Forward – Lowering the blade.

Forward locked – Float mode, only its own weight presses the blade down.

Lower the blade to the ground before leaving or parking the roller.

WARNING



**Use the blade only when driving FORWARD.**

## Strike-off blade

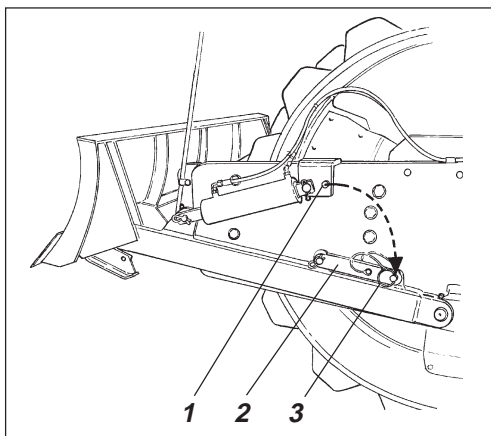

**Fig. 27 Strike-off blade**  
1. Locking pin  
2. Safety link  
3. Parking catch

When using the strike-off blade, the safety link (2) must be secured with its locking pin in the parking catch (3).



## BRAKING

### EMERGENCY BRAKING

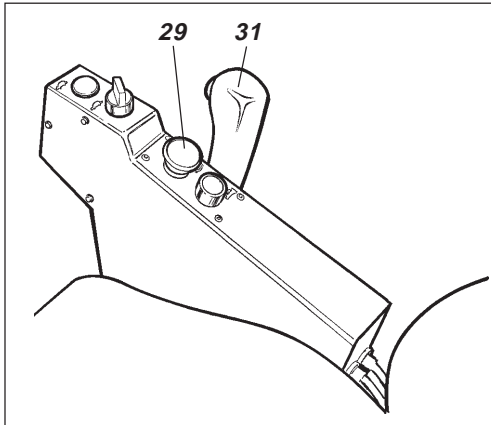

**Fig. 28 Control panel**  
29. Reserve brake knob  
31. Forward/Reverse control

Braking is normally made with the forward/reverse lever (32). The hydrostatic transmission brakes the roller when the lever is moved towards the neutral mode.

In addition, disc brakes in the drum motor and in the rear axle act as a parking brake when stationary.



**WARNING**  
In an emergency, press the reserve brake knob (29). Hold the steering wheel firmly and brace yourself for a sudden stop.

After emergency braking, return the forward/reverse lever to neutral and pull out the reserve brake knob to make the roller ready for driving again.

### Normal braking

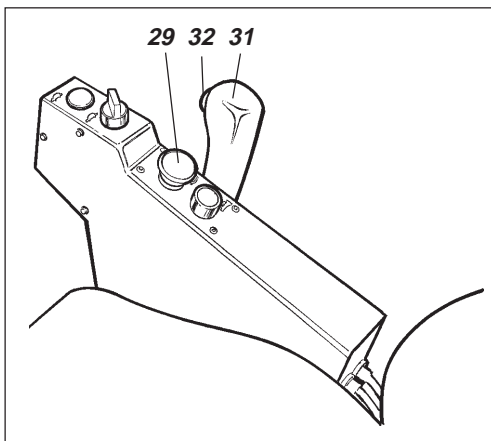

**Fig. 29 Control panel**  
29. Parking/Reserve brake knob  
31 Forward/Reverse lever  
32. Switch, vibration ON/OFF

Press the switch (32) to disengage vibration.

Move the forward/reverse lever (31) to neutral to stop the roller.



**WARNING**  
Always press the parking brake knob (29), even for brief stops on sloping ground.



**CAUTION**  
Turn back the revs control to idling and allow the engine to idle for five minutes to cool down.



**WARNING**  
When starting up and driving a cold machine, which implies cold hydraulic fluid, the braking distance will be longer than normal until the machine reaches working temperature.

### Switching OFF

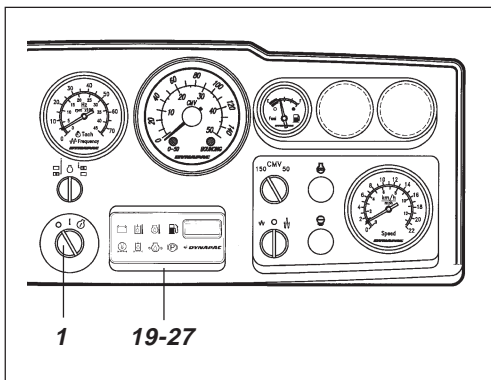

**Fig. 30 Instrument panel**  
1. Starter switch  
19-27. Warning lamp panel

Check instruments and warning lamps to see if any faults are indicated, switch off the lights and other electrical functions.

Turn the starter switch (1) to position **O**. Lower the instrument cover (accessory on rollers without cab) and lock it.



## PARKING

### Chocking the drum

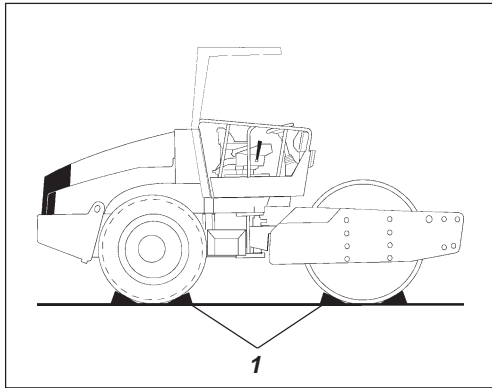

**Fig. 31 Chocking the drum**  
1. Chock



Never leave the machine with the engine running unless the reserve/parking brake knob is pressed in.



Make sure the roller is parked safely and is not a traffic hazard. Chock the drums when parking on sloping ground.



Remember the risk of freezing during the winter. Fill the engine cooling system and the screenwash bottle in the cab with suitable anti-freeze mixtures. See also the Maintenance Manual.

### Battery disconnecter

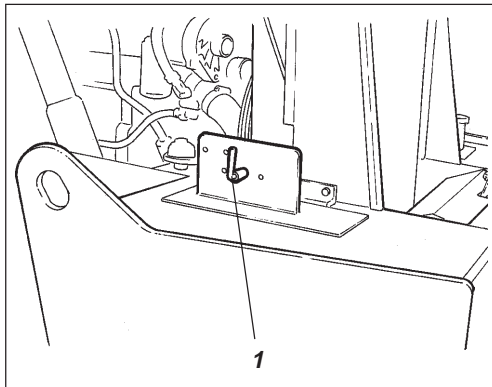

**Fig. 32 Tractor frame, rear left**  
1. Battery disconnecter

Switch the battery disconnecter (1) into disconnected mode and remove the key before leaving the roller.

This will prevent discharging of the battery and will also make it difficult for any unauthorized person to start and drive the machine. Also lock the engine compartment cover.

# LIFTING

## Locking the articulated joint

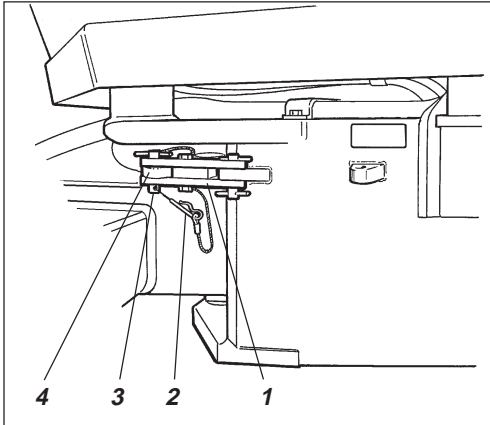

**Fig. 33** Articulation in interlocked mode

1. Locking arm
2. Locking cotter
3. Locking stud
4. Locking lug



**WARNING** Articulation must be locked to prevent inadvertent turning before lifting the roller.

Turn the steering wheel so that the machine is set to drive straight forward. Push in the reserve/parking brake knob.

Pull out the lowermost locking cotter (2) fitted with a wire, pull up locking stud (3) fitted with a wire.

Fold out the locking arm (1) and secure it to the upper locking lug (4) on rear machine frame.

Fit the locking stud (3) in the holes through the locking arm (1) and locking lug (4) and secure the stud in position with the locking cotter (2).

## Lifting the roller

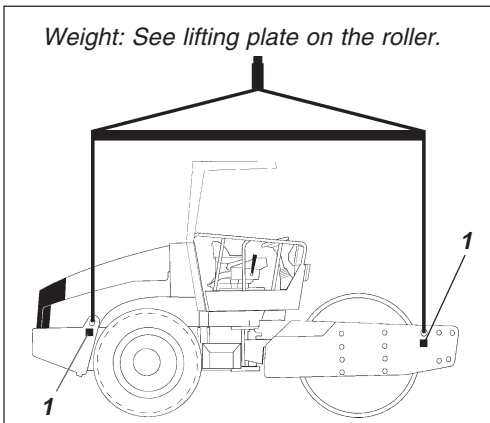

**Fig. 34** Roller prepared for lifting

1. Lifting plate



**WARNING** The gross weight of the machine is noted on the lifting plate (1). See also technical specifications in the maintenance instructions.



**CAUTION** Lifting gear, such as chains, steel wires, straps, and lifting hooks must be dimensioned in conformance with current regulations.



**WARNING** Keep well clear of the lifted machine! Make sure that lifting hooks are securely anchored.

## Releasing the articulated joint

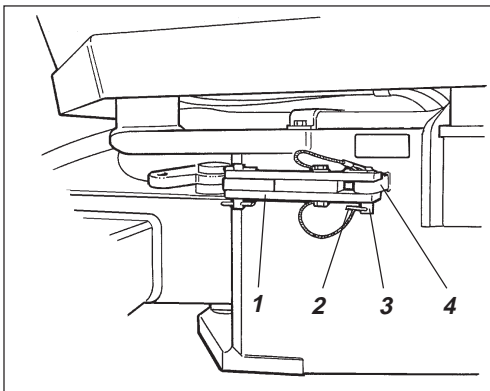

**Fig. 35** Articulation in open mode

1. Locking arm
2. Locking cotter
3. Locking stud
4. Locking lug



**CAUTION** Remember to restore the articulation interlock to its open mode before driving again.

Fold back the locking arm (1) and secure it in the locking lug (4) with the locking stud (3). Insert the lowermost locking cotter (2) fitted with a wire, to secure the locking stud (3). The locking lug (4) is located on the tractor frame.

# TOWING

## Alternative 1 Towing short distance with engine working

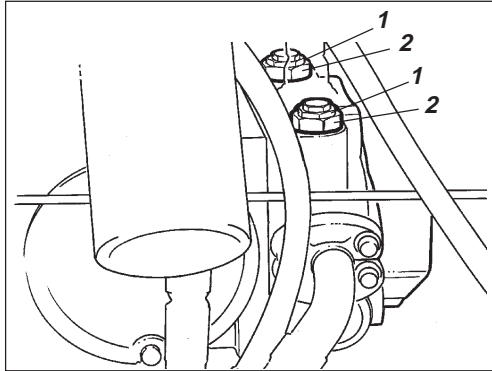

**Fig. 36 Propulsion pump**  
1. Towing valve  
2. Locknut

The roller may be moved a distance of up to 300 metres (330 yards) using either of the following alternatives.



**Press the reserve/parking brake knob, and stop the engine temporarily. Chock the drums to prevent the machine from rolling.**

Open the engine hood. Turn both towing valves (1) (middle hexagonal nut) three turns counter clockwise, while holding the multifunction valve (2) (lowermost hexagonal nut) in place. The valves are located on the upper side of the propulsion pump.

Start the engine and allow it to idle.

The roller can now be towed and can also be steered if the steering system is in action.

## Alternative 2 Towing short distance with engine not working

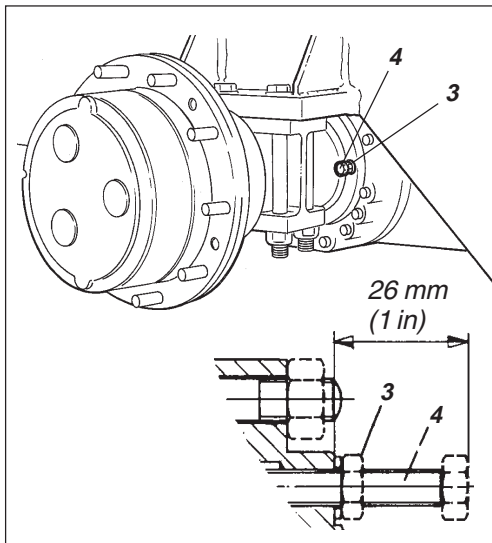

**Fig. 37 Rear axle**  
3. Locknut  
4. Adjusting screw



**Chock the drums as a precaution so the roller does not begin to move when the brakes are disengaged mechanically.**

First, open both of the towing valves according to alternative 1 above.

### Rear axle brake

Undo the locknut (3) and adjust the adjustment screws (4) by hand until resistance increases, and then one additional turn. The adjustment screws are located on the rear axle, two screws on each side of the differential housing.

## TOWING

### Disengaging the drum brake

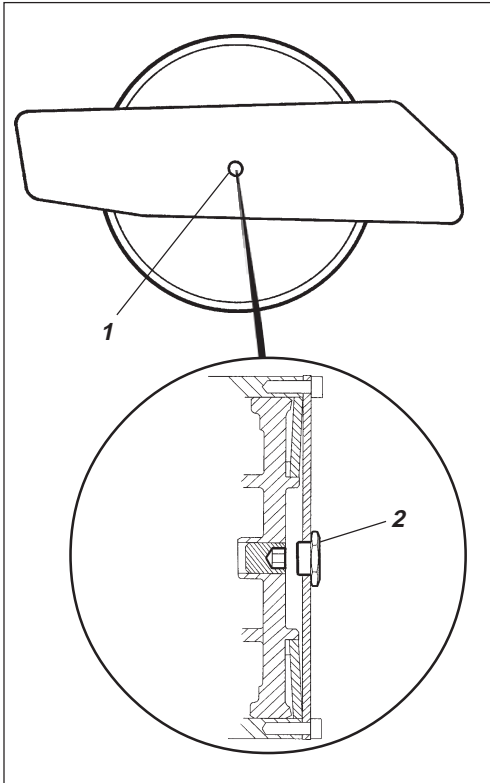
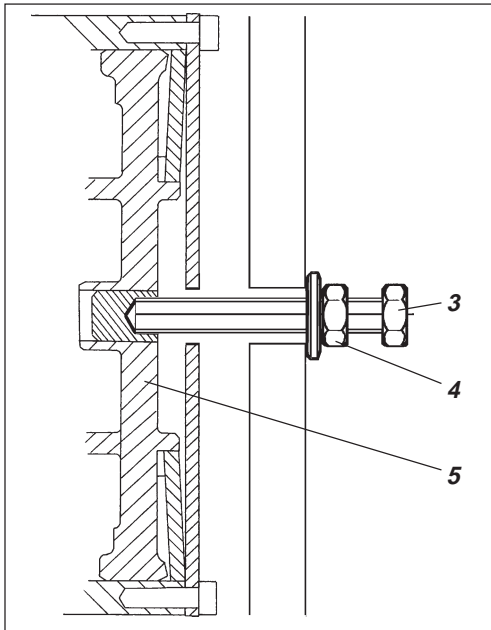

**Fig. 38** Left frame side

- 1. Centre hole
- 2. Centre plug

### Drum motor brake

Screw off the center plug (2) of the drum brake, which is accessible through the center hole (1) in the left side of the frame.



**Fig. 39** Sectional view of brake housing

- 3. Bolt
- 4. Nut
- 5. Brake piston

Screw in the bolt (3) to the bottom according to the figure. Now screw in the nut (4) so that it lies against the washer and then a further 1 1/2 inch while holding the bolt (3).

The brake is now disengaged and the roller can be towed.



After towing, remember to reset the towing valves (1). Unscrew the adjusting screw (4) to its initial position 26 mm (1 inch) from the contact surface, and tighten the lock nuts (3). Also reset the brake of the drum motor.

## TOWING/RETRIEVAL

### Towing a roller

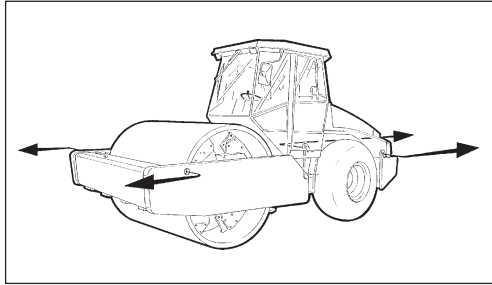

Fig. 40 Towing



**The roller must be counter-braked when towing. Use a towbar because the roller will have no ability to brake.**



The roller must be towed slowly, max. 3 km/h (2 mph) and for a short distance only, max. 300 m (330 yards).

When a machine is towed/retrieved, the towing device must be connected to both lifting holes. Pulling forces shall act longitudinally on the machine as illustrated. Maximum gross pulling force 140 kN (31.5 lbf).



Restore the items for towing according to alternative 1 or 2 on the preceding page.

## TRANSPORT

### Roller prepared for transport

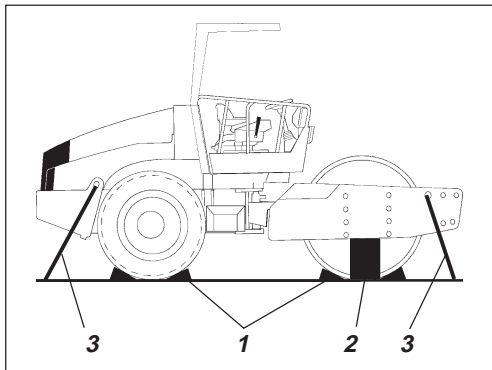

Fig. 41 Transportation

1. Chocks
2. Supporting blocks
3. Lashing wire



**Interlock the articulation before hoisting and transportation. Follow the instructions under the respective heading.**

Chock the drums (1) and secure the chocks to the transport vehicle.

Block up under the drum frame (2), to avoid overload on the rubber suspension of the drum when lashing.

Clamp down the roller with lashing strap (3) at all four corners; decals indicate the fixing points.



Remember to restore the articulation interlock to its open mode before starting the roller again.

## OPERATING INSTRUCTIONS - SUMMARY



1. Follow the **SAFETY INSTRUCTIONS** in the **Safety Manual**.
2. Ensure that all instructions in the maintenance manual are followed.
3. Turn the battery disconnecter to ON.
4. Move the forward/reverse lever to neutral.
5. Set the vibration selector to the **O** mode.
6. Set the revs control to the idling mode.
7. Start the engine and allow it to warm up.
8. Set the revs control in the operating mode.
9. Put the reserve/parking brake knob in the pulled-out position.



10. **Drive the roller. Operate the forward/reverse controls with care.**



11. **Test the brakes.**  
**Remember that the braking distance will be longer if the roller is cold.**

12. Use the vibration only when the roller is in motion.



13. **IN AN EMERGENCY:** - **Push in the reserve/parking brake knob.**  
- **Hold the steering wheel firmly.**  
- **Brace yourself for a sudden stop.**

14. Parking: Push in the reserve/parking brake knob.  
Stop the engine and chock the drums.

15. Lifting: – See the operation manual.

16. Towing: – See the operation manual.

17. Transport: – See the operation manual.

18. Retrieval: – See the operation manual.