

HITACHI

Disc Grinder

Model G 18SE3 • G 18SG2 • G 23SF2
G 23U2 • G 23SE2 • G 23UB2

Handling instructions

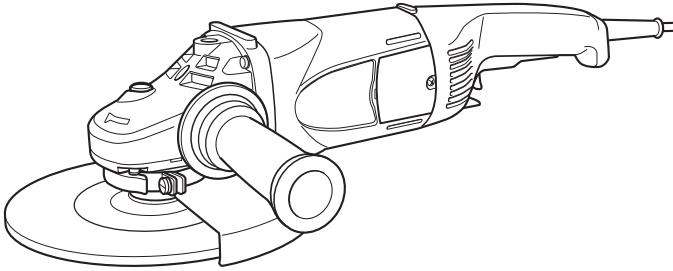

G23SE2

NOTE:

Before using this Electric Power Tool, carefully read through these HANDLING INSTRUCTIONS to ensure efficient, safe operation. It is recommended that these INSTRUCTIONS be kept readily available as an important reference when using this power tool.



Hitachi Koki

GENERAL OPERATIONAL PRECAUTIONS

WARNING! When using electric tools, basic safety precautions should always be followed to reduce the risk of fire, electric shock and personal injury, including the following.

Read all these instructions before operating this product and save these instructions.

For safe operations:

1. Keep work area clean. Cluttered areas and benches invite injuries.
2. Consider work area environment. Do not expose power tools to rain. Do not use power tools in damp or wet locations. Keep work area well lit.
Do not use power tools where there is risk to cause fire or explosion.
3. Guard against electric shock. Avoid body contact with earthed or grounded surfaces. (e.g. pipes, radiators, ranges, refrigerators).
4. Keep children and infirm persons away. Do not let visitors touch the tool or extension cord. All visitors should be kept away from work area.
5. Store idle tools. When not in use, tools should be stored in a dry, high or locked up place, out of reach of children and infirm persons.
6. Do not force the tool. It will do the job better and safer at the rate for which it was intended.
7. Use the right tool. Do not force small tools or attachments to do the job of a heavy duty tool. Do not use tools for purposes not intended; for example, do not use circular saw to cut tree limbs or logs.
8. Dress properly. Do not wear loose clothing or jewelry, they can be caught in moving parts. Rubber gloves and non-skid footwear are recommended when working outdoors. Wear protecting hair covering to contain long hair.
9. Use eye protection. Also use face or dust mask if the cutting operation is dusty.
10. Connect dust extraction equipment.
If devices are provided for the connection of dust extraction and collection facilities ensure these are connected and properly used.
11. Do not abuse the cord. Never carry the tool by the cord or yank it to disconnect it from the receptacle. Keep the cord away from heat, oil and sharp edges.
12. Secure work. Use clamps or a vise to hold the work. It is safer than using your hand and it frees both hands to operate tool.
13. Do not overreach. Keep proper footing and balance at all times.
14. Maintain tools with care. Keep cutting tools sharp and clean for better and safer performance. Follow instructions for lubrication and changing accessories. Inspect tool cords periodically and if damaged, have it repaired by authorized service center. Inspect extension cords periodically and replace, if damaged. Keep handles dry, clean, and free from oil and grease.
15. Disconnect tools. When not in use, before servicing, and when changing accessories such as blades, bits and cutters.
16. Remove adjusting keys and wrenches. Form the habit of checking to see that keys and adjusting wrenches are removed from the tool before turning it on.

17. Avoid unintentional starting. Do not carry a plugged-in tool with a finger on the switch. Ensure switch is off when plugging in.
18. Use outdoor extension leads. When tool is used outdoors, use only extension cords intended for outdoor use.
19. Stay alert. Watch what you are doing. Use common sense. Do not operate tool when you are tired.
20. Check damaged parts. Before further use of the tool, a guard or other part that is damaged should be carefully checked to determine that it will operate properly and perform its intended function. Check for alignment of moving parts, free running of moving parts, breakage of parts, mounting and any other conditions that may affect its operation. A guard or other part that is damaged should be properly repaired or replaced by an authorized service center unless otherwise indicated in this handling instructions. Have defective switches replaced by an authorized service center. Do not use the tool if the switch does not turn it on and off.
21. Warning
The use of any accessory or attachment, other than those recommended in this handling instructions, may present a risk of personal injury.
22. Have your tool repaired by a qualified person.
This electric tool is in accordance with the relevant safety requirements. Repairs should only be carried out by qualified persons using original spare parts. Otherwise this may result in considerable danger to the user.

PRECAUTIONS ON USING DISC GRINDER

1. Never operate these power tools without Wheel Guards.
2. Check that speed marked on the wheel is equal to or greater than the rated speed of the grinder.
Use only depressed center wheels rated at 80m/s or more.
3. Ensure that the wheel dimensions are compatible with the grinder and that the wheel fits the spindle.
4. Abrasive wheels shall be stored and handled with care in accordance with manufacturer's instructions.
5. Inspect the depressed center wheel before use, do not use chipped, cracked or otherwise defective products.
6. Always hold the body handle and side handle of the power tool firmly. Otherwise the counterforce produced may result in inaccurate and even dangerous operation.
7. Do not use cutting-off wheels for side grinding.
8. Do not use of separate reducing bushings or adapters to adapt large hole abrasive wheels.
9. The wheel continues to rotate after the tool is switched off.

SPECIFICATIONS

Model	G18SE3	G18SG2	G23SF2	G23U2	G23SE2	G23UB2
Voltage (by areas)*1	(110V, 220V, 230V, 240V) √					
Input*1	2300 W	2500 W	2000 W		2400 W, 2500 W	
No-load speed	8500 min ⁻¹		6600 min ⁻¹			
Wheel	Outer dia.	180 mm		230 mm		
	Inner dia.	22 mm				
	Peripheral speed	80 m/s				
Weight*2	5.0 kg		4.3 kg		5.0 kg	
Starting current limiter*3	No		No	Yes	No	Yes

*1 Be sure to check the nameplate on product as it is subject to change by areas.

*2 Weight: Only main body

*3 The starting current limiter produces the starting current to such an extent that a fuse (16A, slow-blow) is not tripped.

STANDARD ACCESSORIES

- (1) Wrench 1
 (2) Side handle 1
 Depressed center wheels are not provided as standard accessories.

Standard accessories are subject to change without notice.

APPLICATIONS

- Removal of casting fin and finishing of various types of steel, bronze and aluminum materials and castings.
- Grinding of welded sections or sections cut by means of a cutting torch.
- Grinding of synthetic resins, slate, brick, marble, etc.
- Cutting of synthetic concrete, stone, brick, marble and similar materials.

PRIOR TO OPERATION

1. Power source

Ensure that the power source to be utilized conforms to the power requirements specified on the product nameplate.

2. Power switch

Ensure that the power switch is in the OFF position. If the plug is connected to a receptacle while the power switch is in the ON position, the power tool will start operating immediately, which could cause a serious accident.

3. Extension cord

When the work area is removed from the power source, use an extension cord of sufficient thickness and rated capacity. The extension cord should be kept as short as practicable.

4. Fitting and adjusting the wheel guard

The wheel guard is a protective device to prevent injury should the depressed center wheel shatter during operation. Ensure that the guard is properly fitted and fastened before commencing grinding operation.

[Adjusting the wheel guard, For G23SF2, G23U2 only]

- By slightly loosening the setting screw, the wheel guard can be turned and set at any desired angle for maximum operational effectiveness.
- Ensure that the setting screw is thoroughly tightened after adjusting the wheel guard.

[Installing and adjusting the wheel guard, For G18SE3, G18SG2, G23SE2, G23UB2 only]

- Open the lever and insert the locating pin of wheel guard, bringing it into line with the across flats of packing ground.
- Then, turn the wheel guard to a desired position (for use).
- Close the lever and fix it. If and when required, carry out adjustments by tightening or loosening the screw.
- If the lever does not move smoothly, apply some lubricating oil to the sliding section between the set piece and the lever.
- Fasten the wheel guard at the position where the across flats of the wheel guard positioning pin and packing ground are aligned (the position where the wheel guard is inserted), but do not use it.

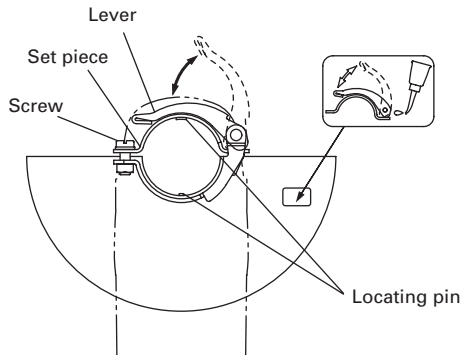

Fig. 1

5. Ensure that the depressed center wheel to be utilized is the correct type and free of cracks or surface defects. Also ensure that the depressed center wheel is properly mounted and the wheel nut is securely tightened, refer to the section on “Depressed Center Wheel Assembly”.
6. **Conducting a trial run**
Ensure that the abrasive products is correctly mounted and tightened before use and run the tool at no-load for 30 seconds in a safe position, stop immediately if there is considerable vibration or if other defects are detected.
If this condition occurs, check the machine to determine the cause.
7. **Confirm the spindle lock mechanism**
Confirm that the spindle lock is disengaged by pushing push button two or three times before switching the power tool on (See Fig. 3).
8. **Fixing the side handle**
Screw the side handle into the gear cover.

PRACTICAL GRINDER APPLICATION

1. Pressure

To prolong the life of the machine and ensure a first class finish, it is important that the machine should not be overloaded by applying too much pressure. In most applications, the weight of the machine alone is sufficient for effective grinding. Too much pressure will result in reduced rotational speed, inferior surface finish, and overloading which could reduce the life of the machine.

2. Grinding angle

Do not apply the entire surface of the depressed center wheel to the material to be ground. As shown in Fig. 2, the machine should be held at an angle of 15° – 30° so that the external edge of the depressed center wheel contacts the material at an optimum angle.

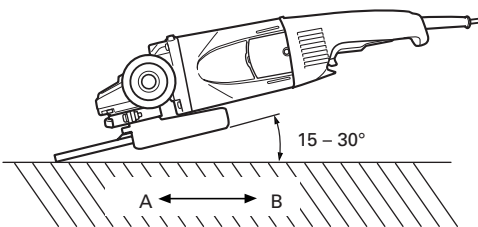

Fig. 2

3. To prevent a new depressed center wheel from digging into the workpiece, initial grinding should be performed by drawing the grinder across the workpiece toward the operator (Fig. 2 direction B). Once the leading edge of the depressed center wheel is properly abraded, grinding may be conducted in either direction.
4. **Switch operation**
Switch ON: Push the locking button forward and then press the switch lever.
* For continuous use, press the switch lever. The switch lever is locked by

pushing the locking button forward once again.
(*Subject to change depending on area.)

Switch OFF: Press and release the switch lever.

5. Precautions immediately after finishing operation

After switching off the machine, do not put it down until the depressed center wheel has come to a complete stop. Apart from avoiding serious accidents, this precaution will reduce the amount of dust and swarf sucked into the machine.

CAUTION:

- Check that the work piece is properly supported.
- Ensure that ventilation openings are kept clear when working in dusty conditions.
If it should become necessary to clear dust, first disconnect the tool from the mains supply (use non-metallic objects) and avoid damaging internal parts.
- Ensure that sparks resulting from use do not create a hazard e.g. do not hit persons, or ignite flammable substances.
- Always use protective safety glasses and hearing protectors, use other personal protective equipment such as gloves, apron and helmet when necessary.
- Always use eye and ear protection.
Other personal protective equipment such as dust mask, gloves, helmet and apron should be worn when necessary.
If in doubt, wear the protective equipment.
- When the machine is not use, the power source should be disconnected.

ASSEMBLING AND DISASSEMBLING THE DEPRESSED CENTER WHEEL AND OTHER TOOLS

CAUTION:

Be sure to switch OFF and disconnect the attachment plug from the receptacle to avoid a serious accident.

1. Assembling (Fig. 3)

- (1) Turn the machine upside down so that the spindle is facing upward.
- (2) Mount the wheel washer onto the spindle.
- (3) Fit the protruding part of the depressed center wheel or cutting wheel or diamond wheel onto the wheel washer.
- (4) Screw the wheel nut onto the spindle.
(For diamond wheel assembling, use the wheel nut with the convex side against the diamond wheel.)
- (5) Insert the push button to prevent rotation of the spindle, and tighten the wheel nut with the accessory wrench, as shown in Fig. 3.

2. Disassembling

Follow the above procedures in reverse.

CAUTION:

- Confirm that the depressed center wheel is mounted firmly.
- Confirm that the push button is disengaged by pushing push button two or three times before switching the power tool on.

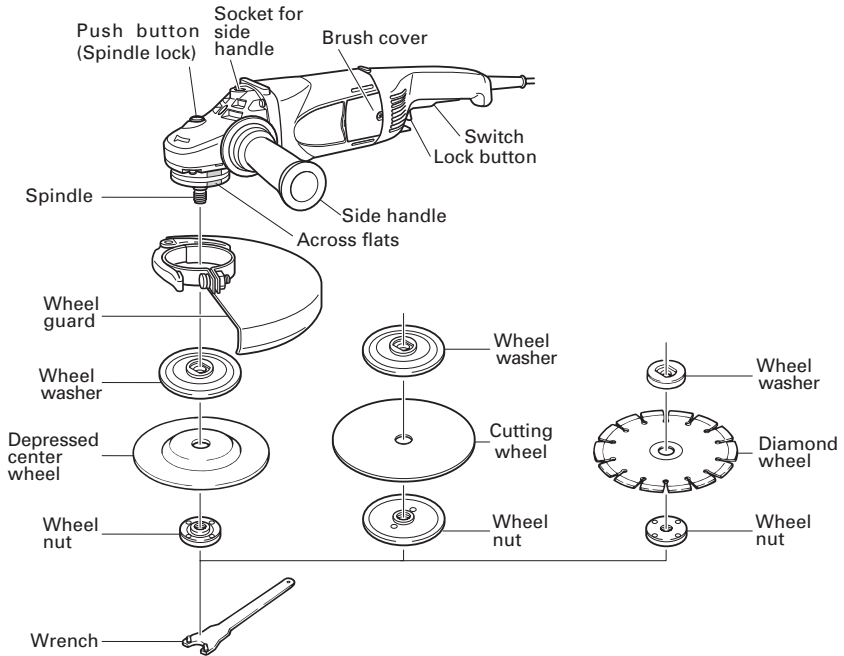

Fig. 3

MAINTENANCE AND INSPECTION

1. Inspecting the depressed center wheel

Ensure that the depressed center wheel is free of cracks and surface defects.

2. Inspecting the mounting screws

Regularly inspect all mounting screws and ensure that they are properly tightened. Should any of the screws be loose, retighten them immediately. Failure to do so could result in serious hazard.

3. Inspecting the carbon brushes

For your continued safety and electrical shock protection, carbon brush inspection and replacement on this tool should ONLY be performed by a Hitachi Authorized Service Center.

4. Replacing supply cord

If the supply cord of Tool is damaged, the Tool must be returned to Hitachi Authorized Service Center for the cord to be replaced.

5. Maintenance of the motor

The motor unit winding is the very "heart" of the power tool. Exercise due care to ensure the winding does not become damaged and/or wet with oil or water.

6. Service parts list

- A: Item No.
- B: Code No.
- C: No. Used
- D: Remarks

CAUTION:

Repair, modification and inspection of Hitachi Power Tools must be carried out by an Hitachi Authorized Service Center.

This Parts List will be helpful if presented with the tool to the Hitachi Authorized Service Center when requesting repair or other maintenance.

In the operation and maintenance of power tools, the safety regulations and standards prescribed in each country must be observed.

MODIFICATIONS:

Hitachi Power Tools are constantly being improved and modified to incorporate the latest technological advancements.

Accordingly, some parts (i.e. code numbers and/or design) may be changed without prior notice.

NOTE:

Due to HITACHI's continuing program of research and development, the specifications herein are subject to change without prior notice.

G18SE3

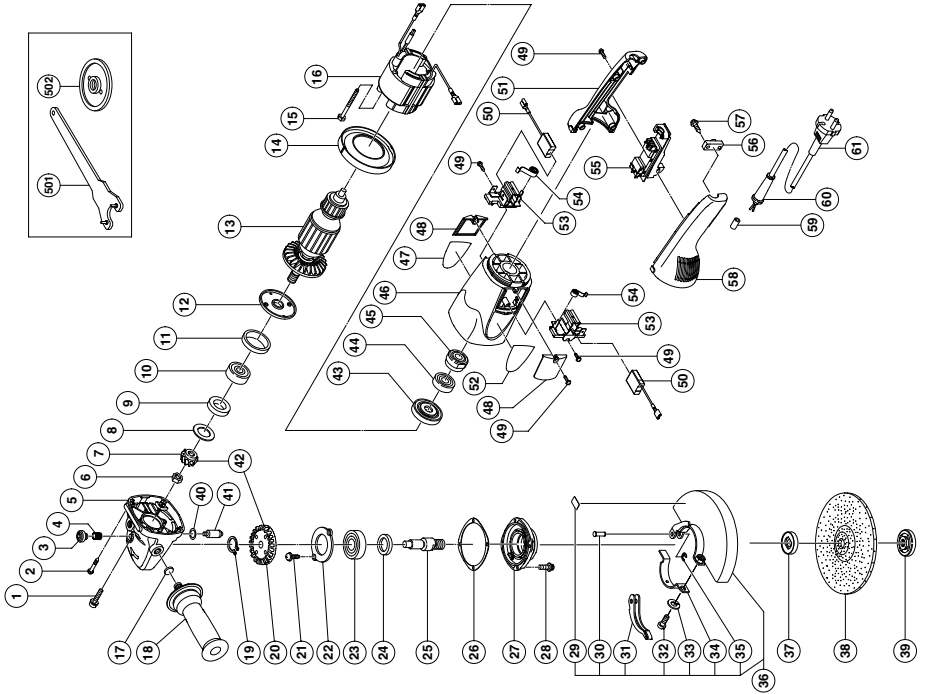

A	B	C	D
1	315-636	2	M5×14
2	301-654	4	D5×35
3	306-888	1	
4	320-219	1	"3, 4, 17, 40, 41"
5	320-217	1	41"
6	320-226	1	M10
7	320-243	1	
8	320-221	1	
9	320-222	1	
10	630-1DD	1	6301DDCMPS2L
11	994-208	1	
12	320-220	1	
13	360-594U	1	"110V-120V" "9, 10, 43, 44"
13	360-594E	1	220V-230V
13	360-594F	1	240V
14	320-215	1	
15	984-271	2	D5×75
16	340-546C	1	110V-120V
16	340-546E	1	220V-230V
16	340-546F	1	240V
17	937-033	1	
18	321-542	1	
19	939-542	1	
20	320-242	1	
21	949-236	2	M5×10
22	320-229	1	
23	630-2DD	1	6302DDCMPS2L
24	990-852	1	
25	320-234	1	
26	320-228	1	
27	320-227	1	
28	994-192	4	M5×16
29	311-492	1	
30	321-545	1	
31	321-546	1	
32	306-887	1	M8×22
33	949-457	1	M8
34	321-544	1	
35	673-489	1	
36	321-543	1	"29-35"
37	937-908Z	1	
38	316-824	1	180MM A24R
39	937-909Z	1	
40	320-218	1	
41	306-890	1	"7, 20"
42	320-241	1	
43	320-216	1	
44	600-0VV	1	6000VVCMP2L
45	321-536	1	
46	321-535	1	"45"
47		1	
48	320-232	2	
49	305-812	8	D4×16
50	999-061	2	
51	320-231	1	
52		1	
53	320-233	2	
54	320-245	2	
55	320-238	1	
56	960-266	1	
57	984-750	2	D4×16
58	320-230	1	
59	981-373	2	
60	958-049	1	D8.2
61	500-408Z	1	
501	937-913Z	1	
502	937-917Z	1	

G18SG2

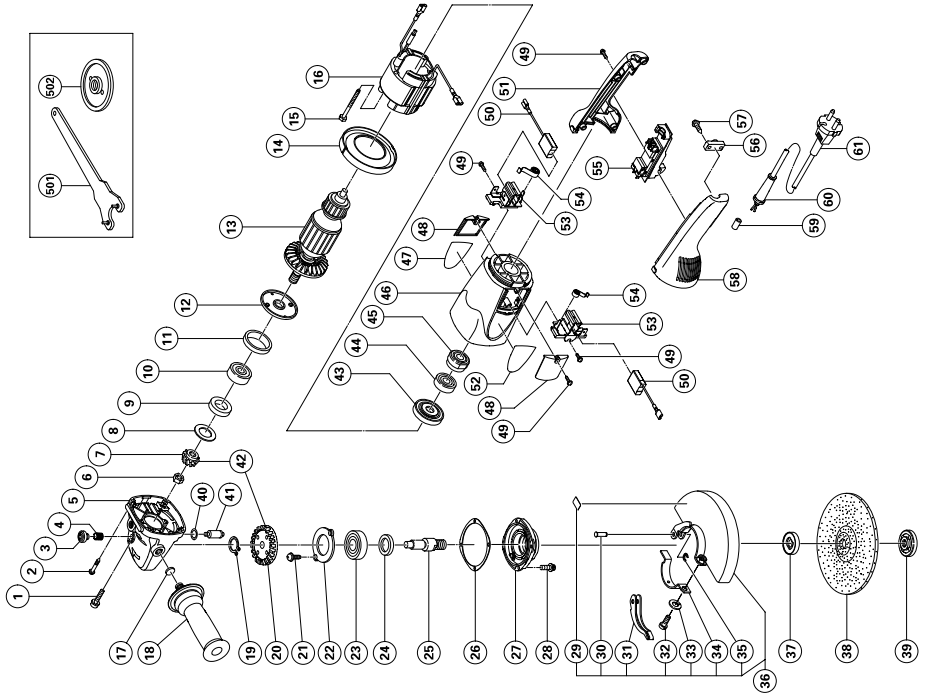

A	B	C	D
1	315-636	2	M5×14
2	301-654	4	D5×35
3	306-888	1	
4	320-219	1	
5	320-217	1	"3, 4, 17, 40, 41"
6	320-226	1	M10
7	320-243	1	
8	320-221	1	
9	320-222	1	
10	630-1DD	1	6301DDCMPS2L
11	994-208	1	
12	320-220	1	
13	360-594E	1	220V-230V
14	320-215	1	
15	984-271	2	D5×75
16	340-546E	1	220V-230V
17	937-033	1	
18	321-542	1	
19	939-542	1	
20	320-242	1	
21	949-236	2	M5×10
22	320-229	1	
23	630-2DD	1	6302DDCMPS2L
24	990-852	1	
25	320-234	1	
26	320-228	1	
27	320-227	1	
28	994-192	4	M5×16
29	311-492	1	
30	321-546	1	
31	321-545	1	
32	306-887	1	M8×22
33	949-457	1	M8
34	321-544	1	
35	673-489	1	
36	321-543	1	"29-35"
37	937-907Z	1	"NZL"
37	937-908Z	1	

A	B	C	D
38	316-824	1	180MM A24R "NZL"
39	937-909Z	1	
40	320-218	1	
41	306-890	1	
42	320-241	1	"7, 20"
43	320-216	1	
44	600-0VV	1	6000VVCMP2L
45	321-536	1	
46	321-535	1	"45"
47		1	
48	320-232	2	
49	305-812	8	D4×16
50	999-061	1	
50	999-089	1	
51	320-231	1	
52		1	
53	320-233	2	
54	320-245	2	
55	320-238	1	
55	320-239	1	"ESP, AUT"
56	960-266	1	
57	984-750	2	D4×16
58	320-230	1	
59	981-373	2	
60	1 940-778	1	D10.7
60	958-049	1	D8.2
61		1	
501	937-913Z	1	"NZL"
502	937-917Z	1	

G23SF2

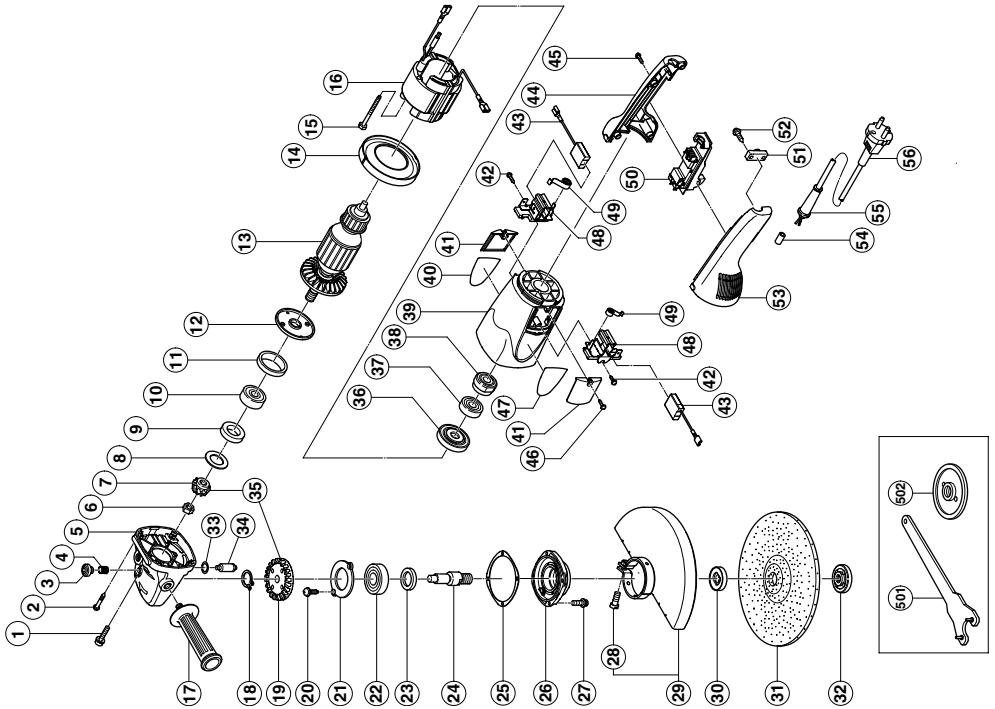

A	B	C	D
1	315-636	2	M5×14
2	301-654	4	D5×35
3	306-888	1	
4	320-219	1	
5	320-217	1	"3, 4, 33, 34"
6	320-226	1	M10
7	320-225	1	
8	320-221	1	
9	320-222	1	
10	630-1DD	1	6301DDUCMPS2S
11	994-208	1	
12	320-220	1	
13	360-558E	1	220V-240V
14	320-215	1	
15	961-501	2	D5×60
16	340-501E	1	220V-230V
16	340-501F	1	240V
17	937-981	1	
18	939-542	1	
19	320-224	1	
20	949-236	2	M5×10
21	320-229	1	
22	630-2DD	1	6302DDUCMPS2S
23	990-852	1	
24	320-234	1	
25	320-228	1	
26	320-227	1	
27	994-192	4	M5×16
28	306-887	1	M8×22
29	306-120	1	"28"
30	937-908Z	1	
31	316-825	1	230MM A24R
32	937-909Z	1	M14×2
33	320-218	1	
34	306-890	1	
35	320-223	1	"7, 19"
36	320-216	1	
37	600-0VV	1	6000VVCMP2L
38	320-244	1	
39	320-214	1	"38"
40	_____	1	
41	320-232	2	
42	305-812	2	D4×16
43	999-061	1	
43	999-089	1	
44	320-231	1	
45	305-812	4	D4×16
46	305-812	2	D4×16
47	_____	1	
48	320-233	2	
49	320-245	2	
50	320-238	1	
51	960-266	1	
52	984-750	2	D4×16
53	320-230	1	
54	981-373	2	
55	958-049	1	D8.2
56	500-439Z	1	
501	937-913Z	1	
502	937-917Z	1	

G23U2

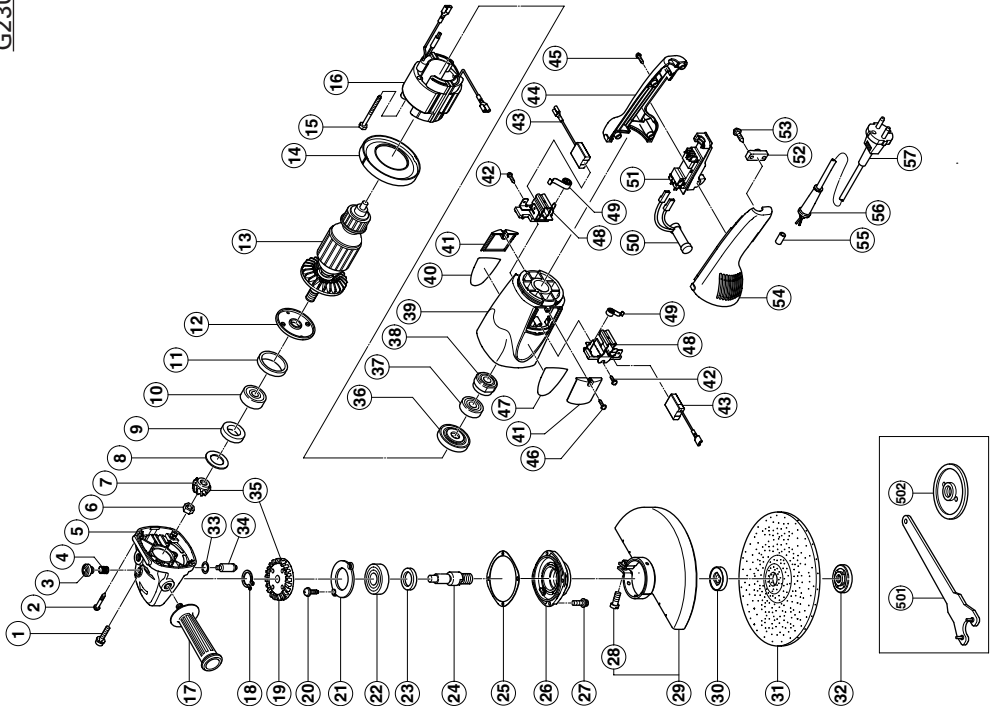

A	B	C	D
1	315-636	2	M5x14
2	301-654	4	D5x35
3	306-888	1	
4	320-219	1	
5	320-217	1	"3, 4, 33, 34"
6	320-226	1	M10
7	320-225	1	
8	320-221	1	
9	320-222	1	
10	630-1DD	1	6301DDUCMPS2S
11	994-208	1	
12	320-220	1	
13	360-558E	1	220V-240V
14	320-215	1	
15	961-501	2	D5x60
16	340-501E	1	220V-230V
16	340-501F	1	240V
17	937-981	1	
18	939-542	1	
19	320-224	1	
20	949-236	2	M5x10
21	320-229	1	6302DDUCMPS2S
22	630-2DD	1	
23	990-852	1	
24	320-234	1	
25	320-228	1	
26	320-227	1	
27	994-192	4	M5x16
28	306-887	1	M8x22
29	306-120	1	"28"
30	937-908Z	1	
31	316-825	1	230MM A24R
32	937-909Z	1	M14x2
33	320-218	1	
34	306-890	1	
35	320-223	1	"7, 19"
36	320-216	1	
37	600-0VV	1	6000VCMPS2L
38	320-244	1	
39	320-214	1	"38"
40			
41			
42			
43			
44			
45			
46			
47			
48			
49			
50			
51			
52			
53			
54			
55			
56			
57			
58			
59			
60			

G23SE2

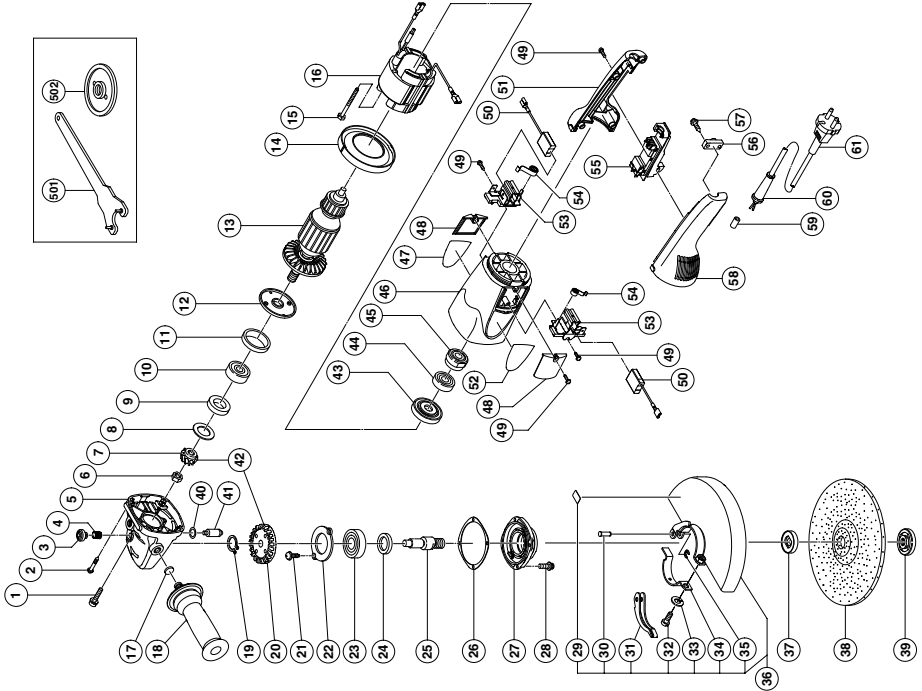

A	B	C	D
1	315-636	2	M5×14
2	301-654	4	D5×35
3	306-888	1	
4	320-219	1	
5	320-217	1	"3, 4, 17, 40, 41"
6	320-226	1	M10
7	320-225	1	
8	320-221	1	
9	320-222	1	
10	630-1DD	1	6301DDCMPS2L
11	994-208	1	
12	320-220	1	
13	360-594E	1	220V-230V
13	360-594F	1	240V
14	320-215	1	
15	984-271	2	D5×75
16	340-546E	1	220V-230V
16	340-546F	1	240V
17	937-033	1	
18	321-542	1	
19	939-542	1	
20	320-224	1	
21	949-236	1	
22	320-229	2	M5×10
23	630-2DD	1	6302DDCMPS2L
24	990-852	1	
25	320-234	1	
26	320-228	1	
27	320-227	1	
28	994-192	4	M5×16
29	311-492	1	
30	321-546	1	
31	321-545	1	
32	306-887	1	M8×22
33	949-457	1	M8
34	321-544	1	
35	673-489	1	
36	321-547	1	"29-35"
37	937-908Z	1	
38	316-825	1	230MM A24R
39	937-909Z	1	
40	320-218	1	
41	306-890	1	"7, 20"
42	320-223	1	
43	320-216	1	6000VVCMP52L
44	600-0VV	1	
45	321-536	1	"45"
46	321-535	1	
47		1	
48	320-232	2	
49	305-812	8	D4×16
50	999-061	2	
51	320-231	1	
52		1	
53	320-233	2	
54	320-245	2	
55	320-238	1	
56	960-266	1	
57	984-750	2	D4×16
58	320-230	1	
59	981-373	2	
60	958-049	1	D8.2
61	500-408Z	1	
501	937-913Z	1	
502	937-917Z	1	

G23UB2

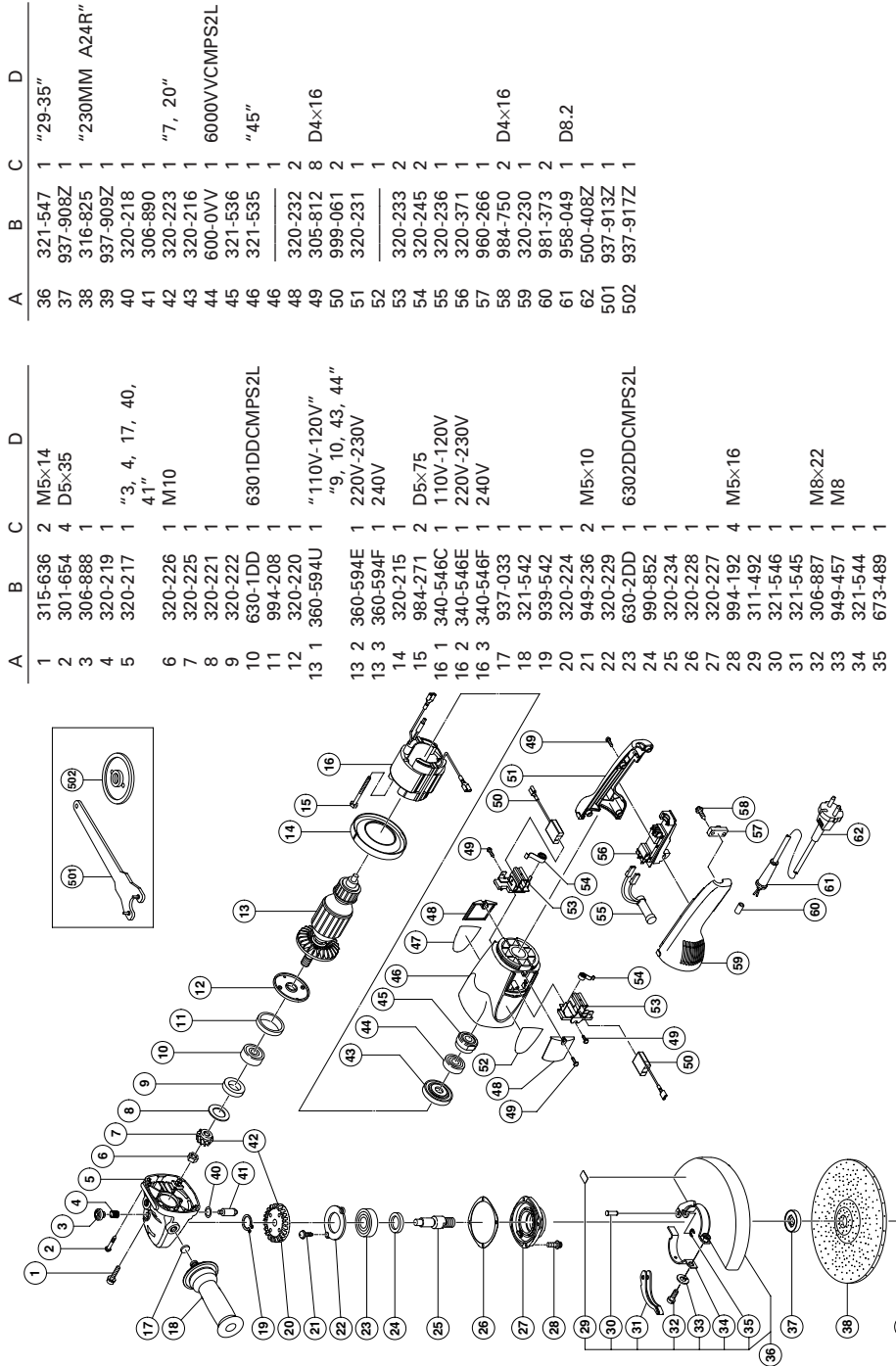

A	B	C	D
36	321-547	1	"29-35"
37	937-908Z	1	"230MM A24R"
38	316-825	1	
39	937-909Z	1	
40	320-218	1	
41	306-890	1	"7, 20"
42	320-223	1	
43	320-216	1	
44	600-0VV	1	6000VVCMP2S2L
45	321-536	1	
46	321-535	1	"45"
47		1	
48	320-232	2	
49	305-812	8	D4x16
50	999-061	2	
51	320-231	1	
52		1	
53	320-233	2	
54	320-245	2	
55	320-236	1	
56	320-371	1	
57	960-266	1	
58	984-750	2	D4x16
59	320-230	1	
60	981-373	2	
61	958-049	1	D8.2
62	500-408Z	1	
501	937-913Z	1	
502	937-917Z	1	

A	B	C	D
1	315-636	2	M5x14
2	301-654	4	D5x35
3	306-888	1	
4	320-219	1	
5	320-217	1	"3, 4, 17, 40, 41"
6	320-226	1	M10
7	320-225	1	
8	320-221	1	
9	320-222	1	
10	630-1DD	1	6301DDCMP2S2L
11	994-208	1	
12	320-220	1	
13	360-594U	1	"110V-120V" "9, 10, 43, 44"
13	360-594E	1	220V-230V
13	360-594F	1	240V
14	320-215	1	
15	984-271	2	D5x75
16	340-546C	1	110V-120V
16	340-546E	1	220V-230V
16	340-546F	1	240V
17	937-033	1	
18	321-542	1	
19	939-542	1	
20	320-224	1	
21	949-236	2	M5x10
22	320-229	1	
23	630-2DD	1	6302DDCMP2S2L
24	990-852	1	
25	320-234	1	
26	320-228	1	
27	320-227	1	M5x16
28	994-192	4	
29	311-492	1	
30	321-546	1	
31	321-545	1	
32	306-887	1	M8x22
33	949-457	1	M8
34	321-544	1	
35	673-489	1	

 **Hitachi Koki Co., Ltd.**

403
Code No. C99122514
Printed in Malaysia